

NON-ISOLATED DC-DC Converter

3.0-5.5Vin, 0.75- 3.63Vout, 5A

INSTALLATION / APPLICATION NOTE

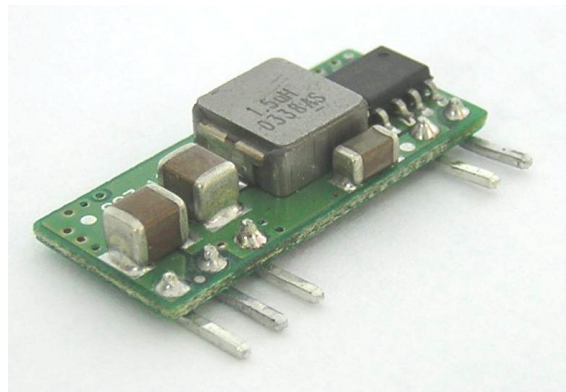

PL5S-05C

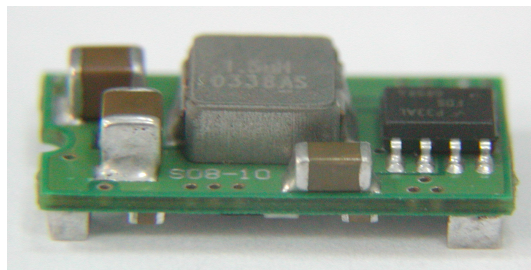

PL5SMS-05C



PL5S-05C, PL5SMS-05C

Application Note

Content

1. INTRODUCTION	3
2. MODELS	3
3. CONVERTER FEATURES	3
4. GENERAL DESCRIPTION	3
4.1 Electrical Description	3
4.2 Thermal Packaging and Physical Design	4
5. MAIN FEATURES AND FUNCTIONS	4
5.1 Operating Temperature Range	4
5.2 Over-Temperature Protection (OTP)	4
5.3 Output Voltage Adjustment	4
5.4 Safe Operating Area (SOA)	4
5.5 Over Current Protection	4
5.6 Remote ON/OFF	4
5.7 UVLO (Under-Voltage Lockout)	5
6. SAFETY	5
6.1 Input Fusing and Safety	5
7. APPLICATIONS	5
7.1 Layout Design	5
7.2 Convection Requirements for Cooling	6
7.3 Thermal Considerations	6
7.4 Power De-Rating Curves	7
7.5 Efficiency vs Load Curves	11
7.6 Input Capacitance	13
7.7 Test Set-Up	13
7.8 Output Voltage Adjustment	14
7.9 Output Ripple and Noise Measurement	14
7.10 Output Capacitance	14
7.11 PL5SMS Reflow Profile	14
8. MECHANICAL	15
8.1 Outline Diagrams	15
8.2 SMS Tape and Reel Dimensions	15

1. Introduction

This application note describes the features and functions of Lambda's PL5S-05C / PL5SMS-05C series of Non Isolated DC-DC Converters. These are highly efficient, reliable and compact, high power density, single output DC/DC converters. These "Point of Load" modules serve the needs specifically of the fixed and mobile telecommunications and computing markets. Capable of operating over a wide input voltage range of 3.0 – 5.5VDC, this series provides a precise regulated output voltage within the range of 0.75V - 3.63Vdc. The ambient operating temperature range is -40°C to +85°C. Ultra-high efficiency operation is achieved through the use of synchronous rectification. The modules are fully protected against short circuit and over-temperature conditions.

2. Models

Model	Input Voltage	Output Voltage	Output Current
PL5S-05C	3.0 – 5.5VDC	0.75 – 3.63VDC	5A
PL5SMS-05C	3.0 – 5.5VDC	0.75 – 3.63VDC	5A

Table 1 – Models

Output Voltage	Output Current	Input Current (mA)		Efficiency typ.
		No Load	Full Load	
0.75V	5A	25	0.949	79%
1.2V	5A	30	1.412	85%
1.5V	5A	30	1.724	87%
1.8V	5A	35	2.022	89%
2.0V	5A	35	2.222	90%
2.5V	5A	35	2.217	92%
3.3V	5A	35	3.511	94%

Table 2 – Efficiency and Input Current

3. Converter Features

- High efficiency topology, typically 94% at 3.3Vdc
- Industry standard footprint
- Wide ambient temperature range, -40°C to +85°C
- Cost efficient open frame design
- Programmable output voltage via external resistor from 0.75 to 3.63Vdc
- No minimum load requirement (Stable at all loads)
- Remote ON/OFF
- Remote sense compensation
- Fixed switching frequency
- Continuous short-circuit protection and over current protection
- Over-temperature protection (OTP)
- Monotonic Startup with pre-bias at the output.
- UL/IEC/EN60950 Certified.

4. General Description

4.1 Electrical Description

A block diagram of the converter is shown in Figure 1. Extremely high efficiency power conversion is achieved through the use of synchronous rectification and drive techniques. Essentially, the powerful topology is based on a non-isolated synchronous buck converter. The control loop is optimized for unconditional stability, fast transient response and a very tight line and load regulation. In a typical pre-bias application the converters do not draw any reverse current at start-up. The output voltage can be adjusted from 0.75 to 3.63vdc, using the TRIM pin with an external resistor. The converter can be shut down via a remote ON/OFF input that is referenced to ground. This input is compatible with popular logic devices; a 'positive' logic input is supplied as standard. Positive logic implies that the converter is enabled if the remote ON/OFF input is high (or floating), and disabled if it is low. The converter is also protected against over-temperature conditions. If the converter is overloaded or the ambient temperature gets too high, the converter will shut down.

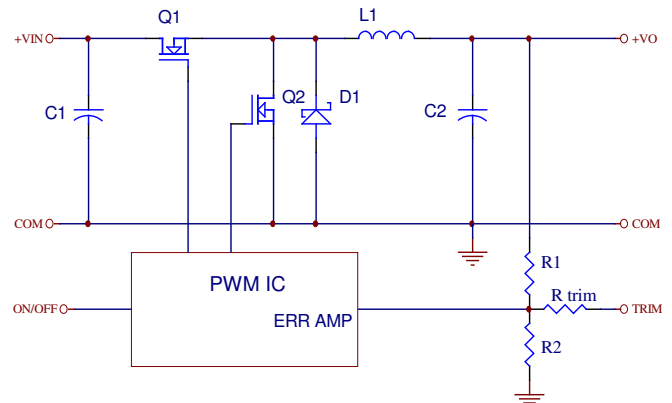

Figure 1. Electrical Block Diagram

4.2 Thermal Packaging and Physical Design

The converter uses a multi-layer FR4 PCB construction. All surface mount power components are placed on one side of the PCB, and all low-power control components are placed on the other side. Thus, the Heat dissipation of the power components is optimized, ensuring that control components are not thermally stressed. The converter is an open-frame product and has no case or case pin. The open-frame design has several advantages over encapsulated closed devices. Among these advantages are:

- **Efficient Thermal Management:** the heat is removed from the heat generating components without heating more sensitive, small signal control components.
- **Environmental:** Lead free open-frame converters are more easily re-cycled.
- **Cost Efficient:** No encapsulation. Cost efficient open-frame construction.
- **Reliable:** Efficient cooling provided by open frame construction offers high reliability and easy diagnostics.

5. Main Features and Functions

5.1 Operating Temperature Range

The converters operate over a wide ambient temperature environment (-40°C to 85°C). Due consideration must be given to the de-rating curves when determining the maximum power that can be drawn from the converter. The maximum power drawn is influenced by a number of factors, such as:

- Input voltage range.
- Output load current.
- Air velocity (forced or natural convection)
- Mounting orientation of converter PCB with respect to the Airflow
- Motherboard PCB design, especially ground and power planes; these can be effective heat sinks for the converter.

5.2 Over-Temperature Protection (OTP)

The converters are equipped with non-latching over-temperature protection. A temperature sensor is located at the hottest point within the converter; typically, on top of the switching device. If the temperature exceeds a threshold of 120°C (typical) the converter will shut down, disabling the output. When the temperature has decreased the converter will automatically start.

The over-temperature condition can be induced by a variety of reasons such as external overload condition or a system fan failure.

5.3 Output Voltage Adjustment

Section 7.8 describes in detail as to how to trim the output voltage with respect to its set point. The output voltage on all models is adjustable over the range of 0.75 – 3.63Vdc.

5.4 Safe Operating Area (SOA)

Figure 2 provides a graphical representation of the Safe Operating Area (SOA) of the converter. This representation assumes ambient operating conditions such as airflow are met as per thermal guidelines provided in Sections 7.2 and 7.3.

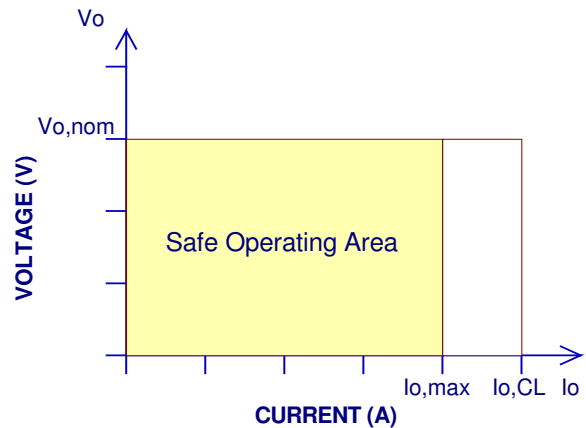

Figure 2. Maximum Output Current Safe Operating Area

5.5 Over Current Protection

All different voltage models have a full continuous short-circuit protection. The unit will auto recover once the short circuit is removed. To provide protection in a fault condition, the unit is equipped with internal over-current protection. The unit operates normally once the fault condition is removed. The power module will supply up to 150% of rated current. In the event of an over current converter will go into a hiccup mode protection.

5.6 Remote ON/OFF

Positive Logic-The remote ON/OFF input feature of the converter allows external circuitry to turn the converter ON or OFF. Active-high remote ON/OFF is available as standard. The converters are turned 'on' if the remote ON/OFF pin is high (=Vin), or left open. Setting the pin low (<0.4Vdc) will turn the converter 'off'. The signal level of the remote on/off input is defined with respect to ground. If remote on/off is not needed, leave the remote on/off pin disconnected, the module will be 'on'.

Negative Logic- Designated with a suffix "N" is the negative on/off version. The unit is "off" if this voltage level is above 2.8Vdc. The converter is 'on' if the on/off pin input is low (<0.4Vdc) or left open. The recommended remote on/off drive circuits are shown in figures 3 and 4.

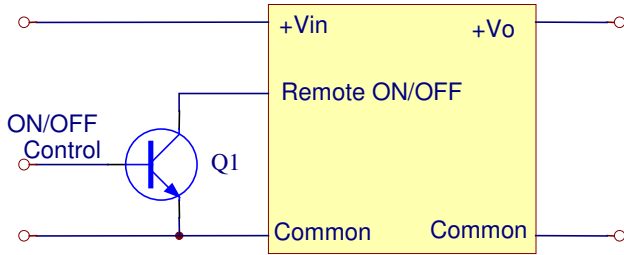

Figure 3. Positive Remote ON/OFF Input Drive Circuit

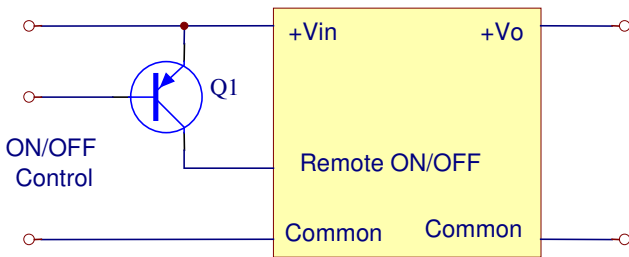

Figure 4. Negative Remote ON/OFF Input Drive Circuit

5.7 UVLO (Under-Voltage Lockout)

When the input Vcc rises above 2.0V the converter initiates a soft start. The UVLO function in the converter has a hysteresis of approximately 100mV to provide noise immunity at start-up.

6. Safety

6.1 Input Fusing and Safety

These products are approved to UL 60950-1:2003, CAN/CSA C22.2 NO.60950-1:2003 and IEC/EN60950-1:2001.

These products are designed to be PCB mounted and for use within other equipment or enclosures. For safe installation and operation, carefully follow the instructions below:

Do not install, test, or operate the products near water or spill liquid on them.

Do not operate these products unless they are securely fastened.

These products must be installed in a restricted access location accessible to authorized personnel only.

These products must be professionally installed in accordance with the prevailing electrical wiring regulations and safety standards.

The output power taken from the unit must not exceed the ratings stated in the catalog datasheet.

Ensure adequate ventilation is provided to allow air to circulate.

This product has functional insulation between input and output and therefore the DC source to this product must be reinforced or double insulated to the AC input in accordance with IEC/EN 60950-1 to achieve SELV output.

Fusing – External ceramic sand-filled fuse, 250V, **F10A**, HBC.

7. Applications

7.1 Layout Design

In optimizing thermal design the PCB is utilized as a heat sink. Some heat is transferred from the module to the main board through connecting pins. The system designer or the end user must ensure that other components and metal in the vicinity of the converter meet the spacing requirements to which the system is approved.

Low resistance and low inductance PCB layout traces are the norm and should be used where possible. Consideration must also be given to proper low impedance traces between the power module and input / output grounds. The recommended footprints are shown in figures 5 and 6.

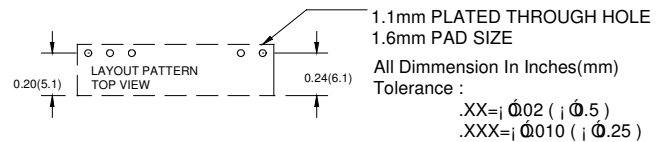

Figure 5. Recommended PL5S Footprint

Recommended Pad Layout

Dimensions are in Inches (millimeters)

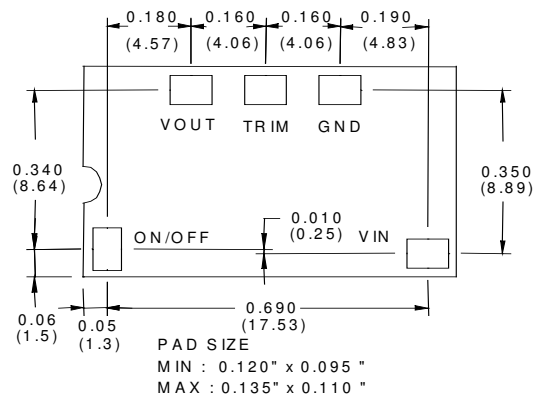

Figure 6. Recommended PL5SMS Footprint (Top View)

Application Note

7.2 Convection Requirements for Cooling

To predict the approximate cooling needed for the module, refer to the Power De-rating curves in Figures 10 and 13. These de-rating curves are approximations of the ambient temperatures and airflow required to keeping the power module temperature below its maximum rating. Once the module is assembled in the actual system, the module's temperature should be checked as shown in Figure 7 to ensure it does not exceed 110°C.

Proper cooling can be verified by measuring the power module's temperature at Q1-pin 6 as shown in Figures 8 and 9.

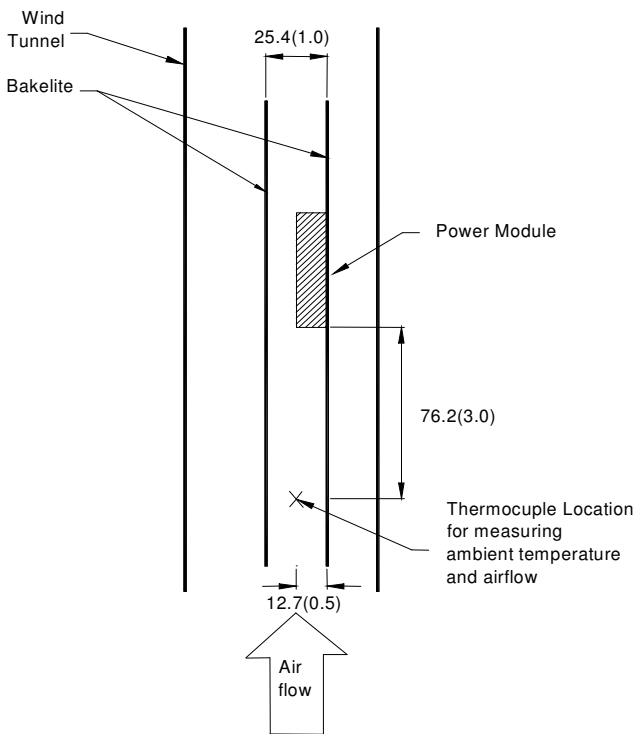

Note: Dimensions are in millimeters and (inches)

Figure 7. Thermal Test Setup

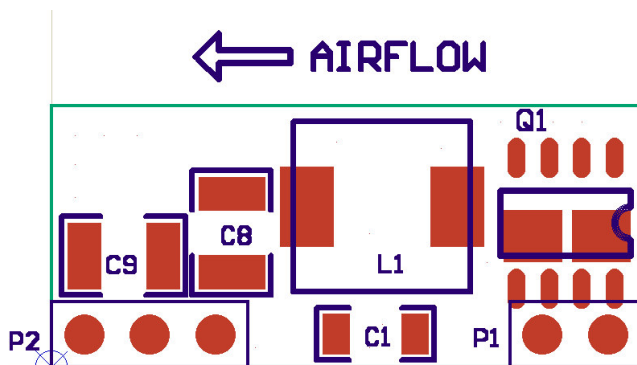

Figure 8. Temperature Measurement Location for PL5S

AIR FLOW ←

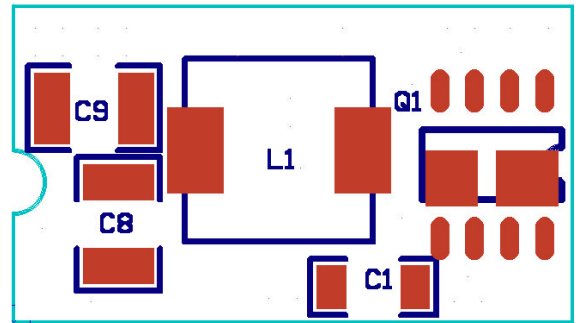

Figure 9. Temperature Measurement Location for PL5SMS

7.3 Thermal Considerations

The power module operates in a variety of thermal environments; however, sufficient cooling should be provided to help ensure reliable operation of the unit. Heat is removed by conduction, convection, and radiation to the surrounding environment. The thermal data presented is based on measurements taken in a set-up as shown in Figure 7. Figures 10 to 13 represent the test data. Note that the airflow is parallel to the long axis of the module as shown in Figure 7 for the converters. The temperature at either location should not exceed 110 °C. The output power of the module should not exceed the rated power for the module (VO, set x IO, max). The thermal data presented is based on measurements taken in a wind tunnel.

7.4 Power De-Rating Curves

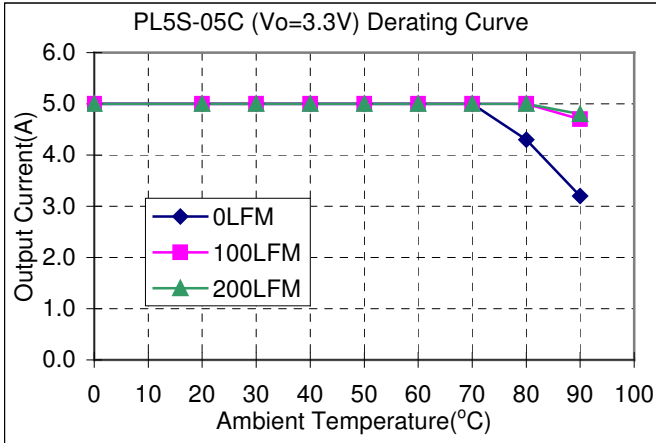

Figure10a. Typical Power De-rating for 5.0V IN 3.3Vout

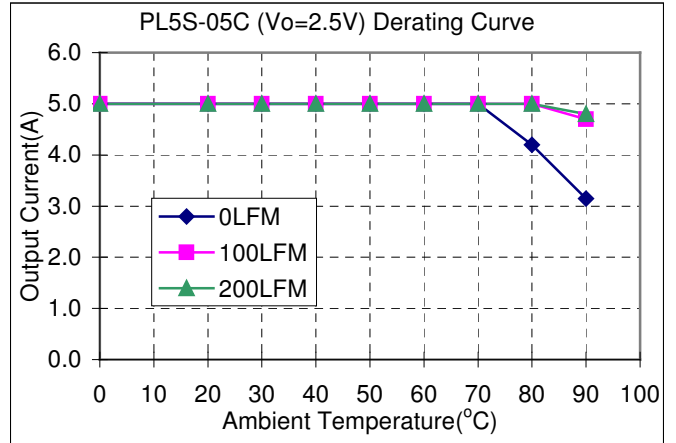

Figure 10b. Typical Power De-rating for 5.0V IN 2.5Vout

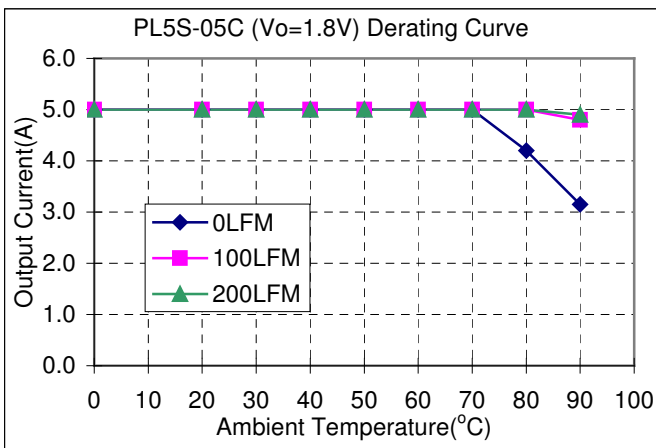

Figure10c. Typical Power De-rating for 5.0V IN 1.8Vout

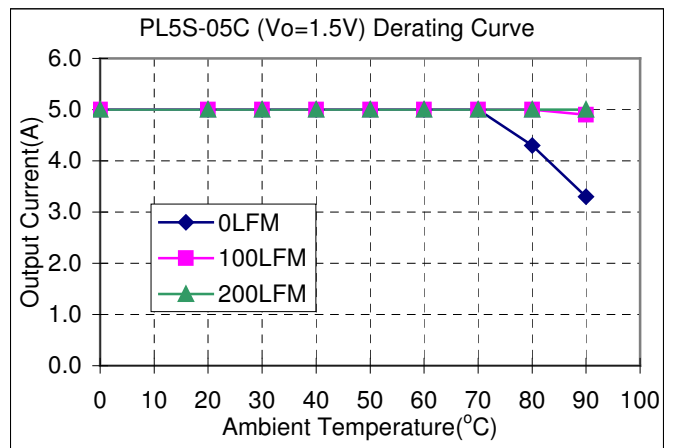

Figure 10d. Typical Power De-rating for 5.0V IN 1.5Vout

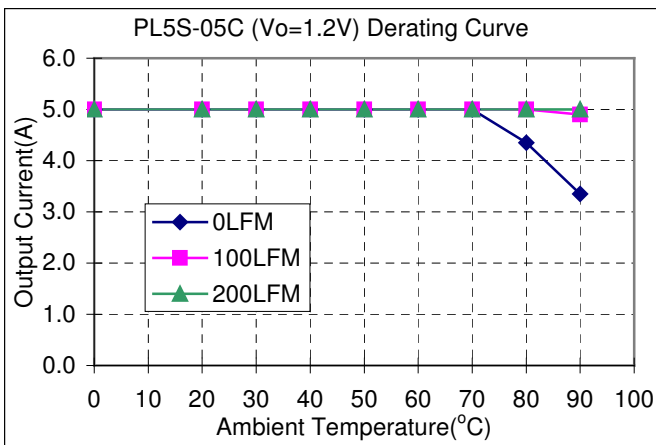

Figure10e. Typical Power De-rating for 5.0V IN 1.2Vout

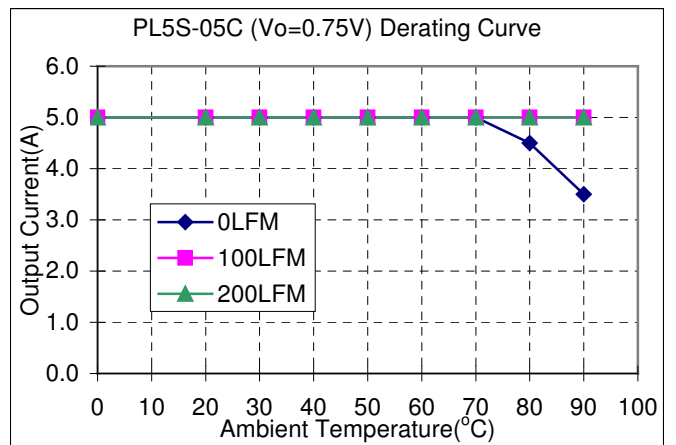

Figure 10f. Typical Power De-rating for 5.0V IN 0.75Vout

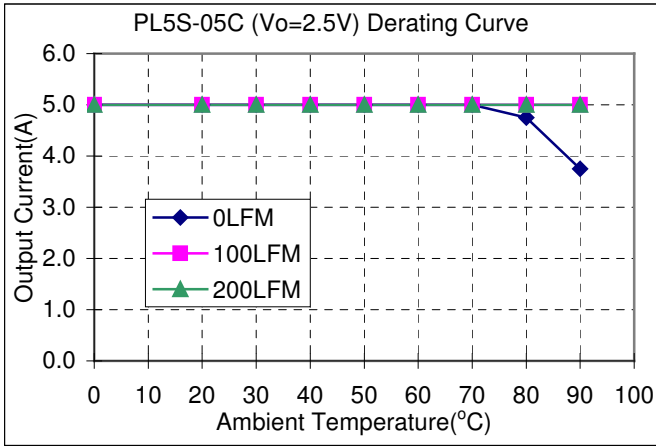

Figure 11a. Typical Power De-rating for 3.3V IN 2.5Vout

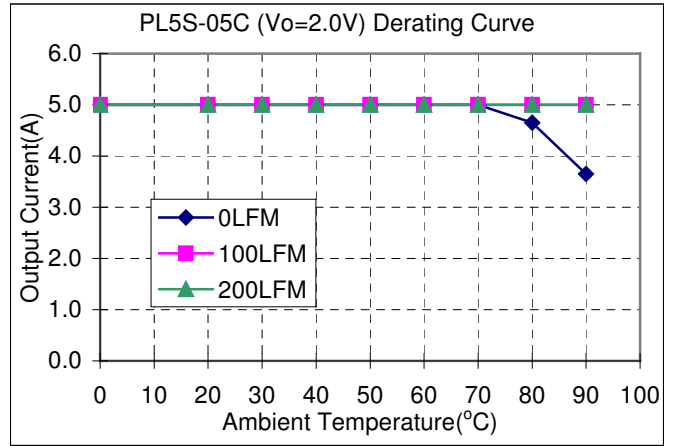

Figure 11b. Typical Power De-rating for 3.3V IN 2.0Vout

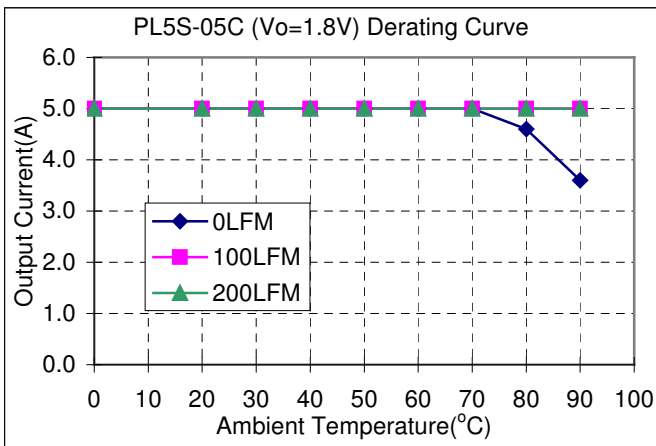

Figure 11c. Typical Power De-rating for 3.3V IN 1.8Vout

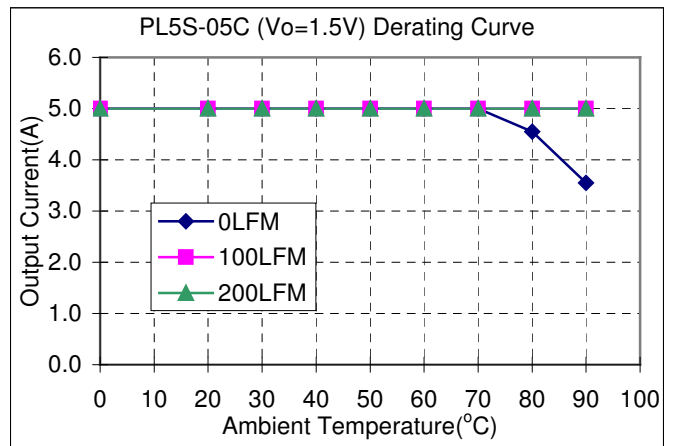

Figure 11d. Typical Power De-rating for 3.3V IN 1.5Vout

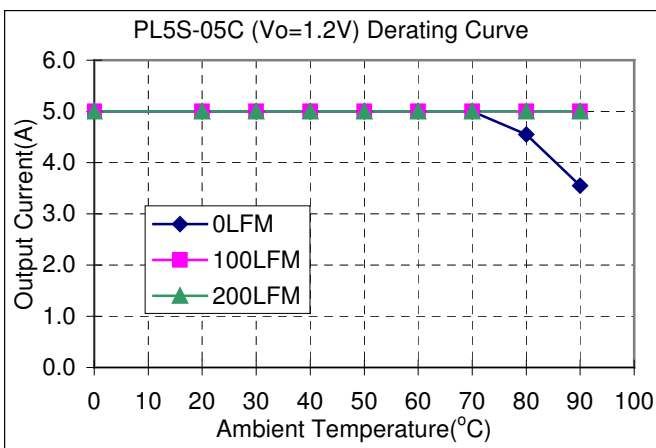

Figure 11e. Typical Power De-rating for 3.3V IN 1.2Vout

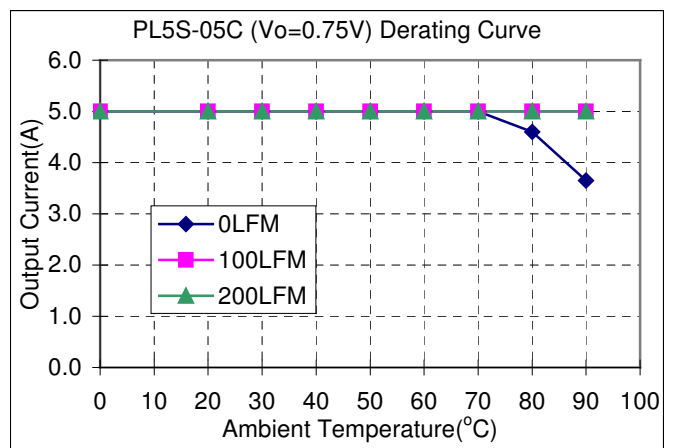

Figure 11f. Typical Power De-rating for 3.3V IN 0.75Vout

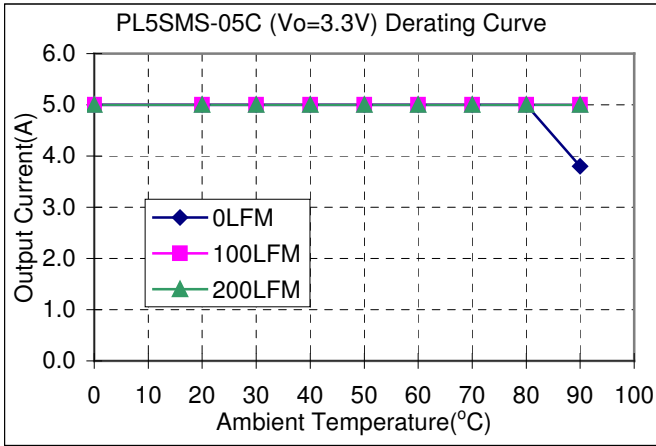

Figure 12a. Typical Power De-rating for 5V IN 3.3Vout

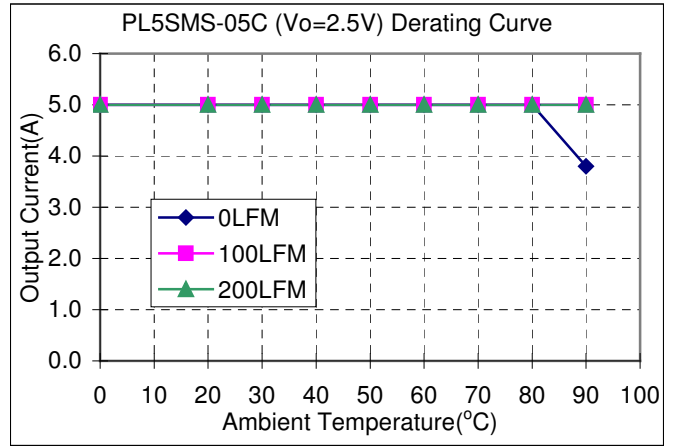

Figure 12b. Typical Power De-rating for 5V IN 2.5Vout

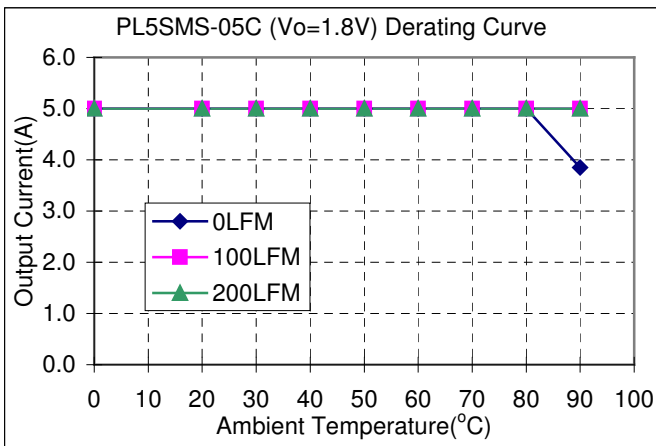

Figure 12c. Typical Power De-rating for 5V IN 1.8Vout

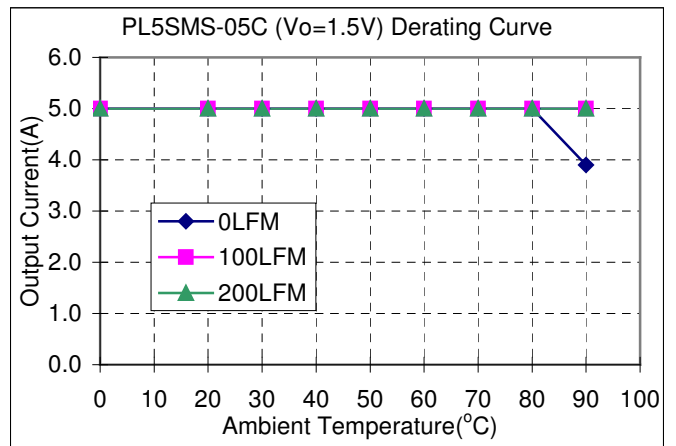

Figure 12d. Typical Power De-rating for 5V IN 1.5Vout

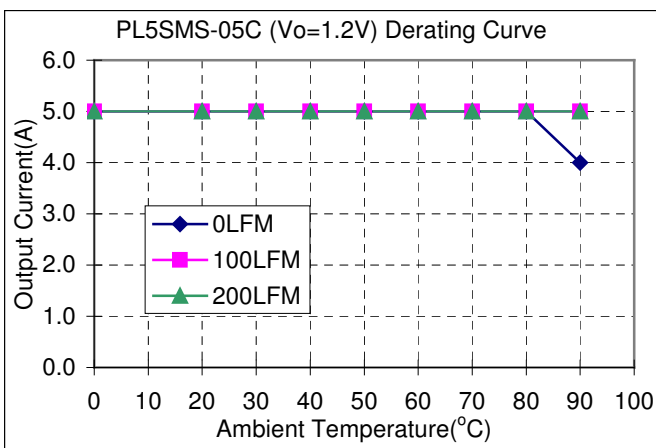

Figure 12e. Typical Power De-rating for 5V IN 1.2Vout

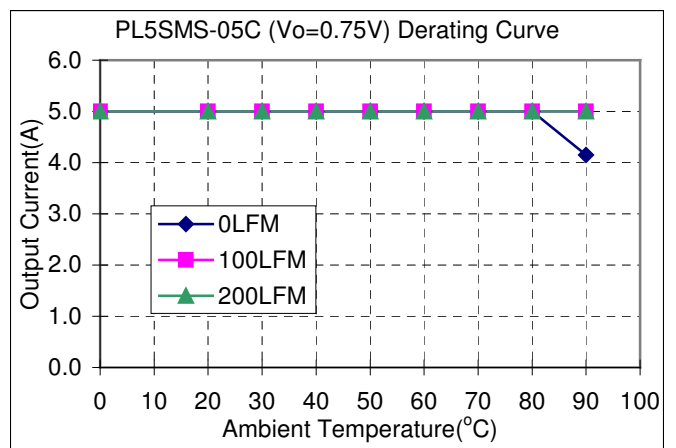

Figure 12f. Typical Power De-rating for 5V IN 0.75Vout

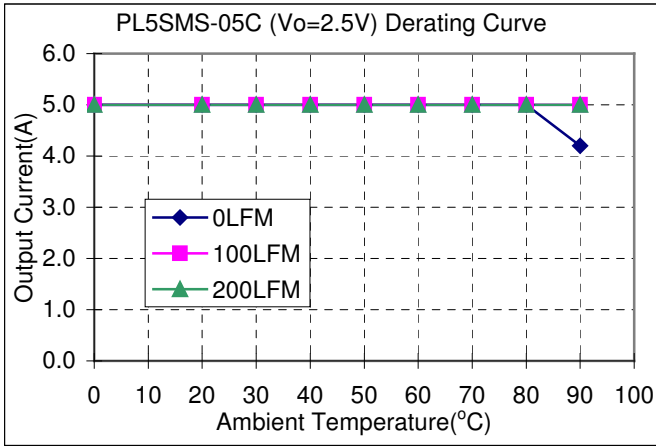

Figure 13a. Typical Power De-rating for 3.3V IN 2.5Vout

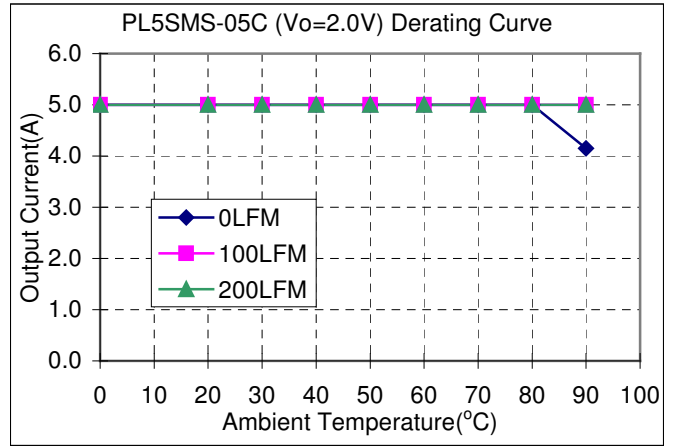

Figure 13b. Typical Power De-rating for 3.3V IN 2.0Vout

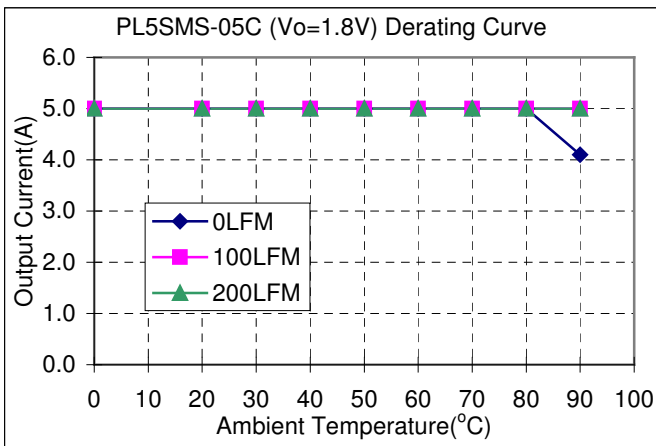

Figure 13c. Typical Power De-rating for 3.3V IN 1.8Vout

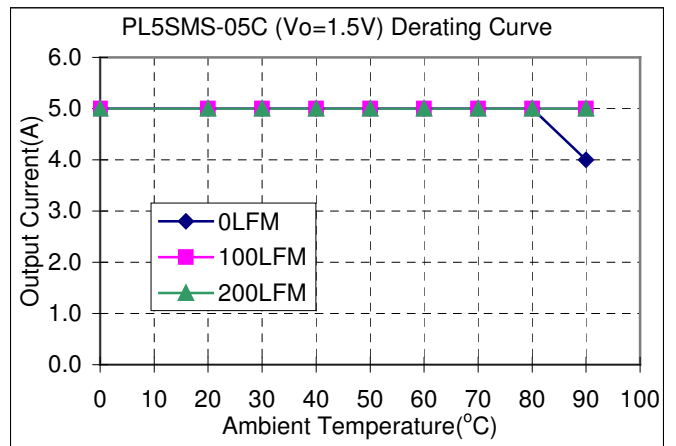

Figure 13d. Typical Power De-rating for 3.3V IN 1.5Vout

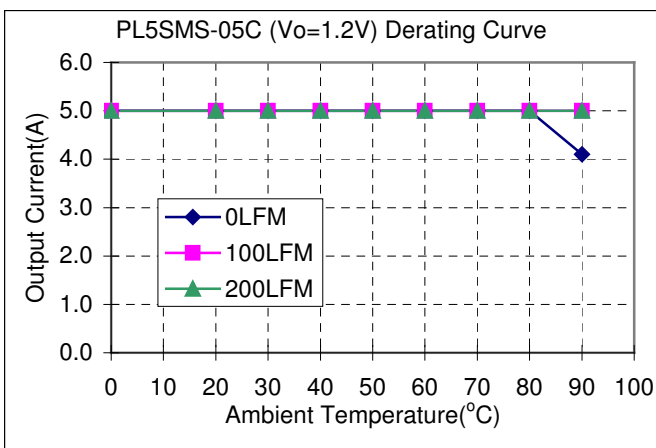

Figure 13e. Typical Power De-rating for 3.3V IN 1.2Vout

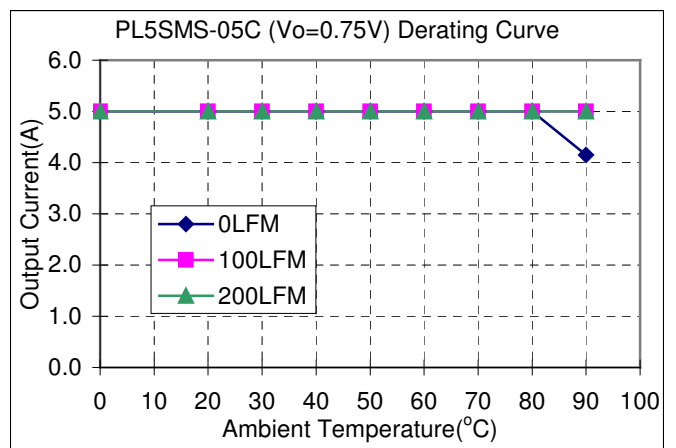
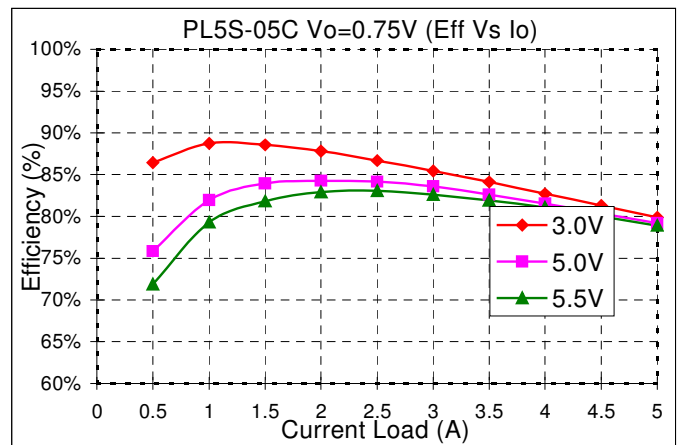
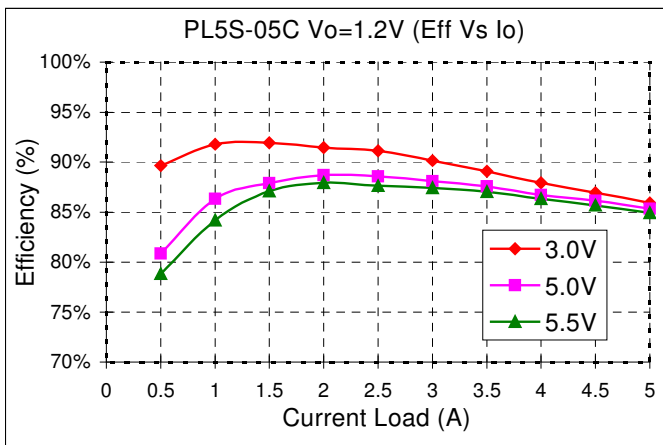
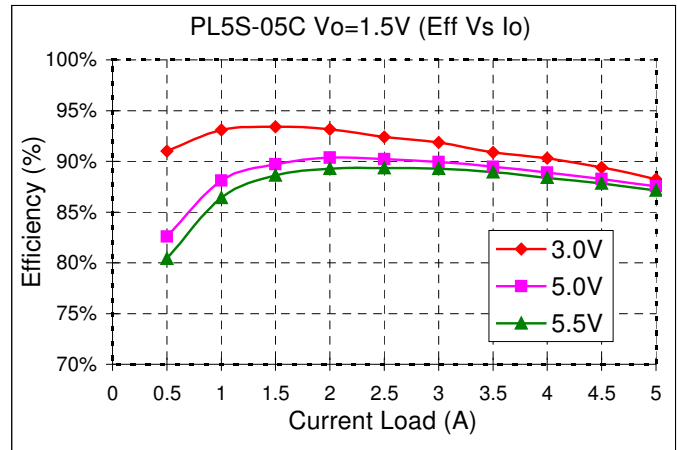
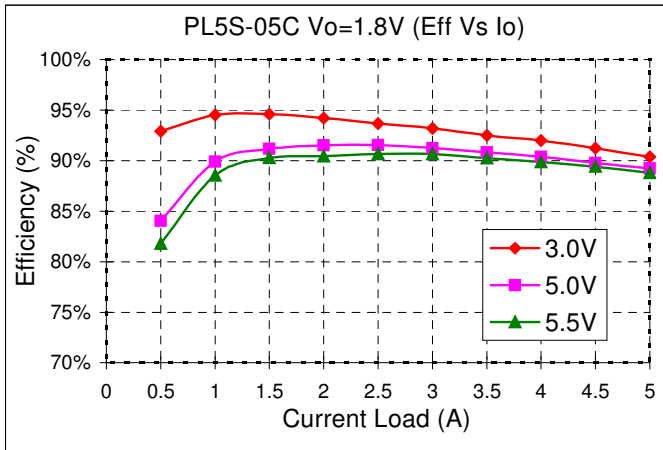
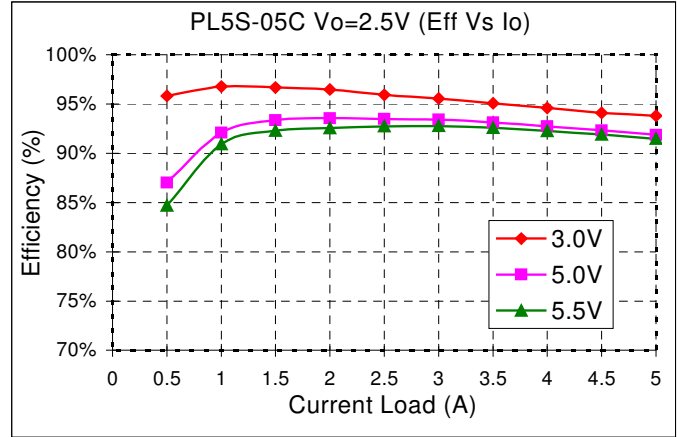
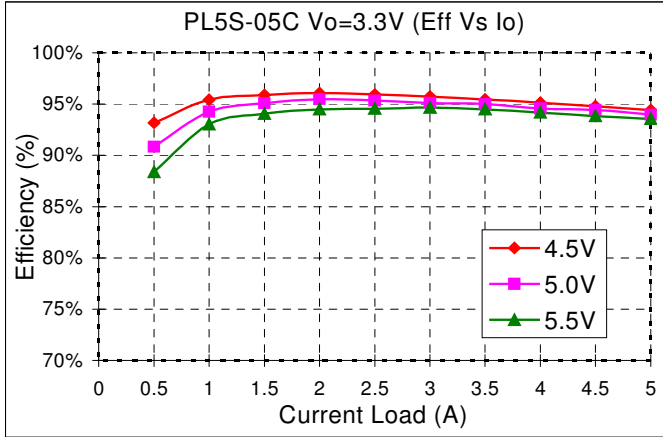

Figure 13f. Typical Power De-rating for 3.3V IN 0.75Vout

7.5 Efficiency vs Load Curves





PL5S-05C, PL5SMS-05C

Application Note

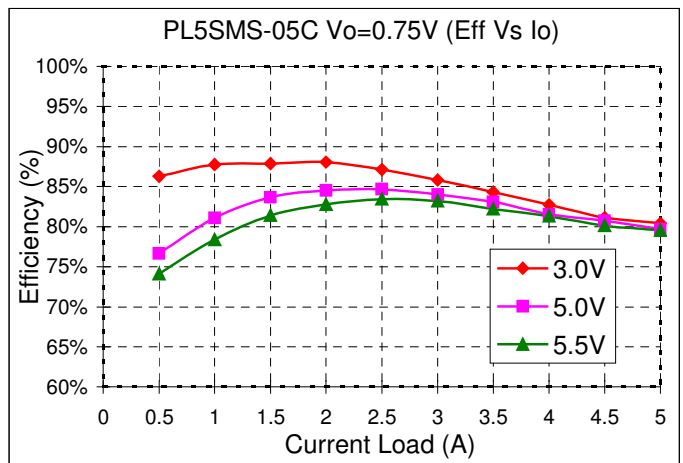
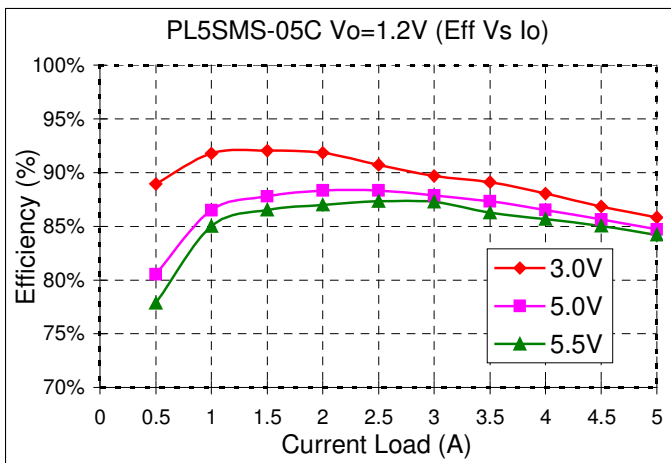
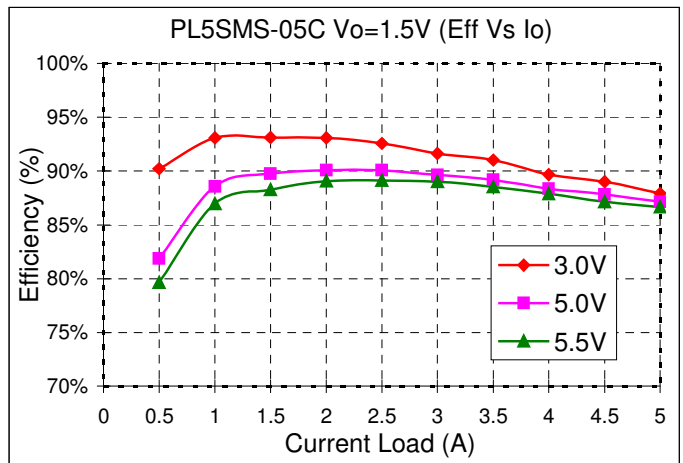
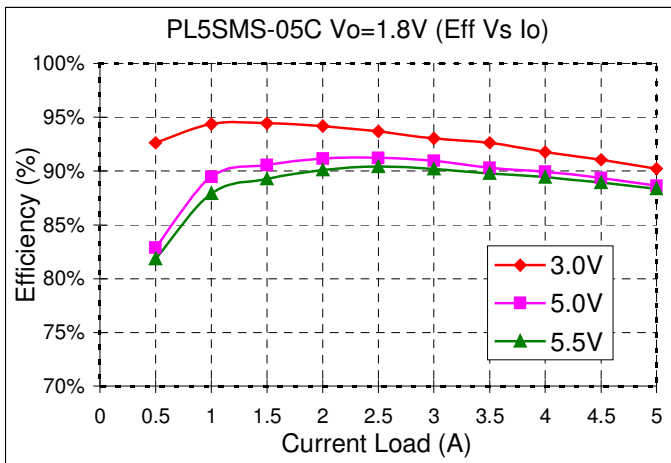
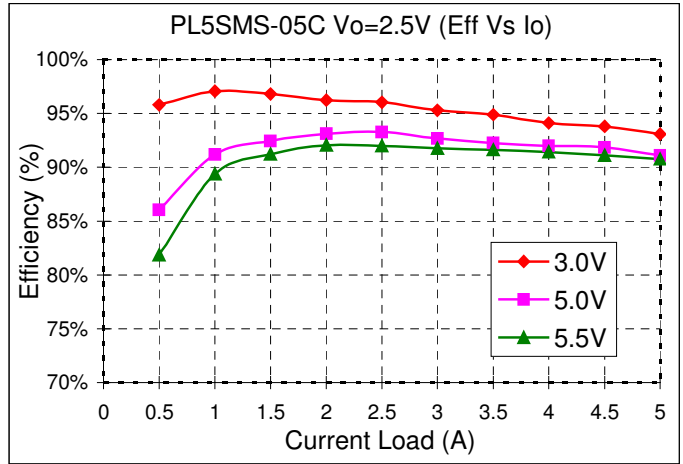
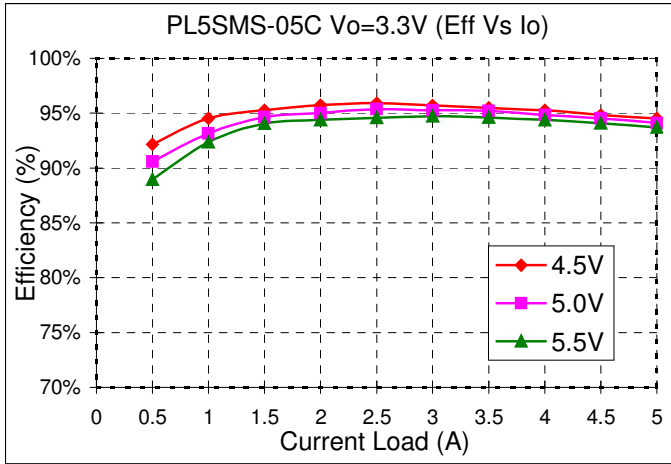

Application Note

7.6 Input Capacitance

The converters must be connected to a low source impedance to avoid problems with loop stability. The input capacitors should be placed close to the converter's input pins to reduce distribution inductance. Input capacitors should have a high capacitance and a low ESR (typically <100m ohms) for suitable ripple handling capability. Electrolytic capacitors should be avoided. The circuit as shown in Figure 14 represents typical measurement methods for ripple current. Input reflected-ripple current is measured with a simulated source Inductance of 1uH. Current is measured at the input of the module.

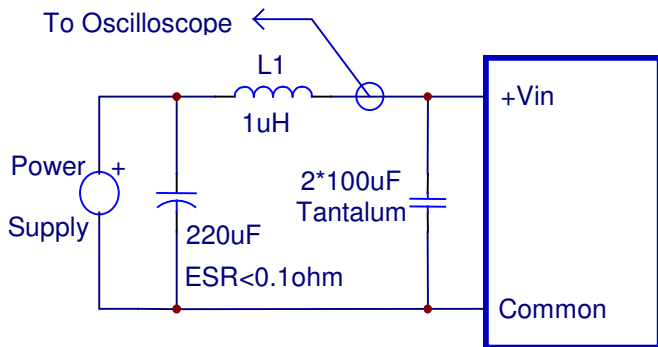

Figure 14. Input Reflected-Ripple Test Setup

7.7 Test Set-Up

The basic test set-up to measure parameters such as efficiency and load regulation is shown in Figure 15. Please note that this converter is non-isolated, as such the input and output share a common ground. These grounds should be connected together via low impedance ground plane in the application. When bench testing a converter ensure that -Vin and -Vo are connected together via a low impedance short to ensure proper efficiency and load regulation measurements. When testing the converter under any transient conditions, ensure that the transient response of the source is sufficient to power the equipment under test. We can calculate the

- Efficiency
- Load regulation and line regulation.

The value of efficiency is defined as:

$$\eta = \frac{V_o \times I_o}{V_{in} \times I_{in}} \times 100\%$$

Where: V_o is output voltage,
 I_o is output current,
 V_{in} is input voltage,
 I_{in} is input current.

The value of load regulation is defined as:

$$Load.reg = \frac{V_{FL} - V_{NL}}{V_{NL}} \times 100\%$$

Where: V_{FL} is the output voltage at full load
 V_{NL} is the output voltage at no load

The value of line regulation is defined as:

$$Line.reg = \frac{V_{HL} - V_{LL}}{V_{LL}} \times 100\%$$

Where: V_{HL} is the output voltage of maximum input voltage at full load.
 V_{LL} is the output voltage of minimum input voltage at full load.

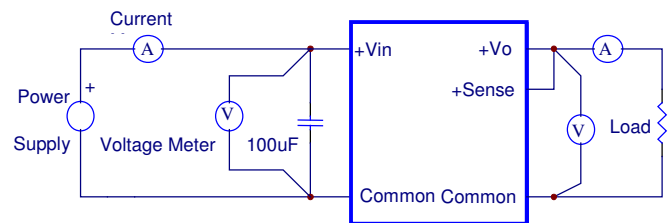

Figure 15. Test Setup

Application Note

7.8 Output Voltage Adjustment

The output voltage of the converter can be adjusted over the range of 0.75V to 3.63V by adding an external resistor (shown as Rtrim) in Figure 17. When Trim resistor is not connected the output voltage defaults to 0.75V

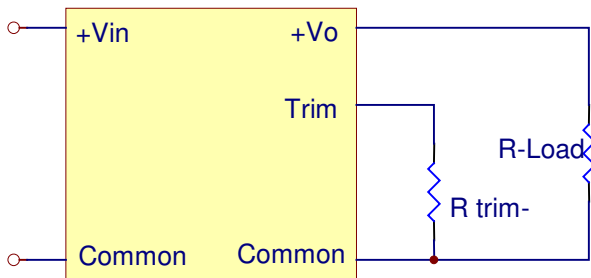

Figure 17. Trim-up Voltage Setup

The value of Rtrim-up defined as:

$$R_{trim} = \left(\frac{21070}{V_o - 0.75} - 5110 \right)$$

Where: Rtrim-up is the external resistor in ohms,
Vo is the desired output voltage

To give an example of the above calculation, to set a voltage of 3.3Vdc, Rtrim is given by:

$$R_{trim} = \left(\frac{21070}{V_o - 0.75} - 5110 \right)$$

Rtrim = 3153 ohm

For various output voltages, the resistance values are provided in Table 3.

Vo,set (V)	Rtrim (kohms)
0.75	Open
1.20	41.71
1.50	22.98
1.80	14.96
2.00	11.75
2.50	6.93
3.30	3.15
3.63	2.20

Table 3 – Trim Resistor Values

7.9 Output Ripple and Noise Measurement

The test set-up for noise and ripple measurements is shown in Figure 18. A coaxial cable with a 50 ohm termination was used to prevent an impedance mismatch.

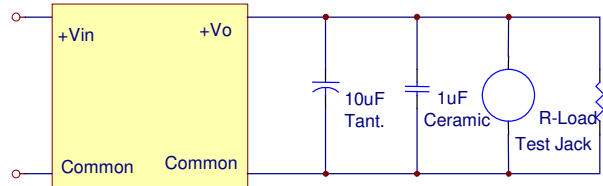

Figure 18. Output Voltage Ripple and Noise Measurement Set-Up

7.10 Output Capacitance

Lambda's converters provide a stable output with or without external capacitors. For good transient response low, ESR output capacitors should be located close to the load.

The converters are designed to work with a load capacitance of up to 3,000uF. It is recommended that any additional capacitance be typically <3,000uF and have a low ESR. This capacitor should be connected close to the load.

7.11 PL5SMS Reflow Profile

An example of the SMS reflow profile is given in Figure 19.

Equipment used: SMD HOT AIR REFLOW HD-350SAR

Alloy: AMQ-M293TA or NC-SMQ92 IND-82088 SN63

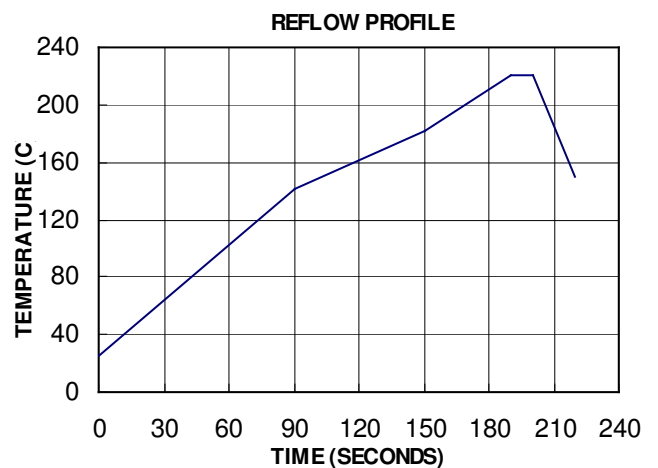

Figure 19 SMS Reflow Profile

8. Mechanical

8.1 Outline Diagrams

Dimensions are in millimeters and inches

Tolerance: x.xx ±0.02 in. (0.5mm) , x.xxx ±0.010 in. (0.25 mm) unless otherwise noted

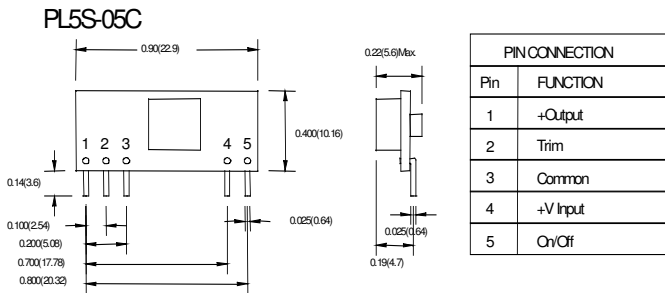

Figure 20 PL5S-05C Mechanical Outline Diagram

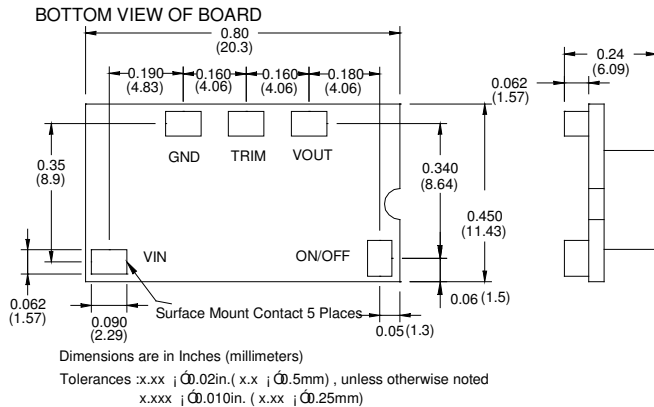
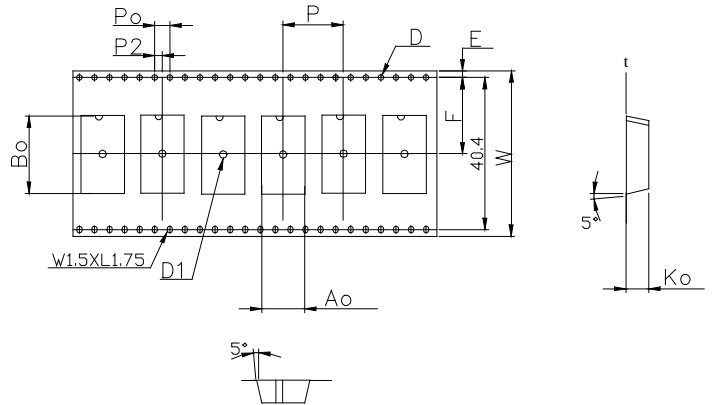

Figure 21 PL5S-05C Mechanical Outline Diagram

8.2 SMS Tape and Reel Dimensions

The Tape Reel dimensions for the SMS module is shown in Figure 22.



ITEM	SPEC
W	44.00 ^{+0.30} _{-0.30}
Ao	11.50 ^{+0.10} _{-0.10}
Bo	20.70 ^{+0.10} _{-0.10}
Ko	6.00 ^{+0.10} _{-0.10}
P	16.00 ^{+0.10} _{-0.10}
F	20.20 ^{+0.10} _{-0.10}
E	1.75 ^{+0.10} _{-0.10}
D	1.50 ^{+0.10} _{-0.00}
D1	2.00 ^{+0.25} _{-0.00}
Po	4.00 ^{+0.10} _{-0.10}
P2	2.00 ^{+0.10} _{-0.10}
t	0.35 ^{+0.05} _{-0.05}

Figure 22 – SMS Tape and Reel Dimensions