

BATTMASTER®

Advanced Wireless Battery Monitoring System

User Manual



Table of contents:

1	Safety information	6
2	Acronyms.....	8
3	System description.....	8
4	Features and benefits	11
5	Functional description.....	11
5.1	Measured parameters.....	11
5.2	Alarms and events.....	11
5.3	Most significant data concept and acquisition intervals	12
5.4	Internal resistance measurement	12
5.5	Discharge cycle count	12
5.6	User Interface	12
5.7	Data storage organization	13
5.8	Notifications	13
5.9	Web server.....	14
5.10	Database	15
5.11	Real Time Logging.....	17
5.12	Digital I/O.....	17
5.13	Sleep	17
5.14	IDAM and DAM firmware update.....	18
5.14.1	Force update of a single device	18
5.14.2	Automatic update using BATTMASTER® software.....	19
5.14.3	Automatic background update	19
5.15	CU LEDs.....	20
5.16	Modbus/TCP	20
6	Installation.....	23
6.1	CU	23
6.2	IDAM.....	24
6.3	DAM.....	25

6.4	BATTMASTER® software	27
7	Configuration	28
7.1	Prerequisites	28
7.2	Connect to CU	28
7.3	System configuration	30
7.3.1	E-Mail notification.....	30
7.3.2	SMS notification	31
7.3.3	Battery models configuration	32
7.3.4	CU configuration.....	33
7.4	Configuring strings and batteries.....	34
7.4.1	Manual string add-on	35
7.4.2	Manual battery add-on.....	37
7.4.3	Automatic string add-on.....	38
7.4.4	Automatic battery add-on	38
7.5	Configuration management	38
8	BATTMASTER® software.....	40
8.1	CU connection	40
8.2	System configuration	40
8.3	System overview.....	40
8.3.1	CU overview	42
8.3.2	String overview	43
8.3.3	IDAM replacement.....	44
8.3.4	Battery overview	45
8.3.5	DAM replacement.....	46
8.3.6	Battery replacement	47
8.3.7	Enable/Disable alarm signaling.....	48
8.3.8	Selective RTL	49
8.3.9	Adjust Ri alarm thresholds	49
8.3.10	Diagnose radio link quality	50
8.4	Database management	51

8.5	Data review	53
8.5.1	CU review.....	54
8.5.2	String review.....	55
8.5.3	Battery review.....	56
8.5.4	Multiple traces view	57
8.5.5	Cursor.....	57
8.5.6	Change trace color	58
8.5.7	Chart zoom	58
8.6	Help.....	59
9	Events and alarms	60
10	Maintenance	69
10.1	CU batteries replacement.....	69
11	Troubleshooting	70
12	Technical specifications	71
12.1	Dimensions.....	71
12.2	General Characteristics	72

DISCLAIMER

NEXTYS reserves the right to make changes without further notice to any products herein. **NEXTYS** makes no warranty, representation or guarantee regarding the suitability of its products for any particular purpose, nor does **NEXTYS** assume any liability arising out of the application or use of any product, and specifically disclaims any and all liability, including without limitation consequential or incidental damages. "Typical" parameters which may be provided in **NEXTYS** data sheets and/or specifications can and do vary in different applications and actual performance may vary overtime. All operating parameters, including "Typicals", must be validated for each customer application by customer's technical experts. **NEXTYS** does not convey any license under its patent rights nor the rights of others. **NEXTYS** products are not designed, intended, or authorized for use as components in systems intended for surgical implant into the body, or other applications intended to support or sustain life, or for any other application in which the failure of the **NEXTYS** product could create a situation where personal injury or death may occur. Should Buyer purchase or use **NEXTYS** products for any such unintended or unauthorized application, Buyer shall indemnify and hold **NEXTYS** and its officers, employees, subsidiaries, affiliates, and distributors harmless against all claims, costs, damages, and expenses, and reasonable attorney fees arising out of, directly or indirectly, any claim of personal injury or death associated with such unintended or unauthorized use, even if such claim alleges that **NEXTYS** was negligent regarding the design or manufacture of the part.

The Customer should ensure that it has the most up to date version of the document by contacting its local **NEXTYS** office. This document supersedes any earlier documentation relating to the products referred to herein. The information contained in this document is current at the date of publication. It may subsequently be updated, revised or withdrawn.

All Trade Marks recognized. Specifications and information herein are Subject to change without notice.

1 Safety information

The instructions in this manual are not intended as a substitute for proper training or adequate experience in the safe operation of the equipment described. Only qualified personnel should work on this equipment after first becoming thoroughly familiar with all warnings, safety notices, and maintenance procedures contained herein and on the devices. The successful and safe operation of this equipment is dependent on proper handling, installation, operation, and maintenance.

Only authorized repair or replacement parts shall be used in this equipment.

All installation instructions must be strictly followed.

Hazard statement definitions

⚠ DANGER	Indicates an imminent hazardous situation which, if not avoided, will result in death or serious injury.
⚠ WARNING	Indicates an imminent hazardous situation which, if not avoided, could result in death or serious injury.
⚠ CAUTION	Indicates an imminent hazardous situation which, if not avoided, may result in minor or moderate injury

⚠ DANGER

HAZARDOUS VOLTAGE.

CAN CAUSE DEATH OR SERIOUS PERSONAL INJURY.

Batteries and battery cabinets contain potentially lethal voltages. To avoid electrical shock or burn, turn of main and control voltages before performing installation or maintenance. Batteries are energized even when AC power has been disconnected.

⚠ WARNING

RISK OF EXPLOSIVE GASSES.

Batteries generate explosive gasses during normal operation, and when discharged or charged.

⚠WARNING

WHEN YOU WORK NEAR LEAD-ACID BATTERIES:

1. Someone should be within range of your voice or close enough to come to your aid if you have an accident.
2. Have plenty of fresh water and soap nearby in case battery acid contacts skin, clothing, or eyes.
3. Wear complete eye protection and protective clothing. Avoid touching your eyes while working near a battery. If battery acid contacts your skin or clothing, wash immediately with soap and water. If acid enters an eye, immediately flood the eye with running cold water for at least 10 minutes and get medical attention as soon as possible.
4. Be extra cautious when handling metal tools around a battery. If you drop a metal tool near a battery it might spark or create a short circuit between the battery terminals and some other metal part. Either event may cause a dangerous electrical shock hazard, a fire, or even an explosion.
5. Remove all personal metal items such as rings, bracelets, necklaces, and watches when working with a lead-acid battery. A lead-acid battery can produce a short-circuited current high enough to weld a metal ring or other piece of jewelry, causing a severe burn.

2 Acronyms

Acronym	Definition
BM	BATTMASTER® Monitoring System
RF	Radio Frequency
CU	Central Unit
DAM	Data Acquisition Module
IDAM	I (current) Data Acquisition Module
DAMs	Data Acquisition Modules (DAM and IDAM)
Ri	Internal resistance of lead acid battery
AI	Acquisition interval
μSD	Micro Secure Digital card

3 System description

BATTMASTER® is a wireless battery monitoring system that measures and logs the voltage, internal resistance, temperature and current of lead acid batteries (2, 6 or 12 V nominal voltage) as individual blocks or within a battery string. It can operate as a standalone system or in conjunction with a PC/LAN.



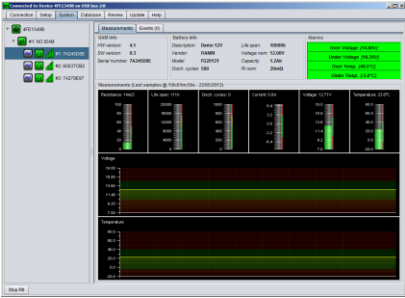
The modular architecture of the system has the benefit to be easily customizable to log other parameters on request (i.e. pressure, humidity, etc.).

BATTMASTER® is composed of 4 components:

CU (Central Unit): Collects and stores the DAM and IDAM data, manages the communication with the PC and sends SMS/E-Mail notifications.



Figure 1: CU

<p>DAM (Data Acquisition Module): Measures the voltage, temperature and internal resistance of the battery and stores the most significant data until the next reading by the CU. All data are time stamped.</p>	 <p>Figure 2: DAM</p>
<p>IDAM (Current Acquisition Module): Measures the current of a battery or a string of batteries, in conjunction with a Hall effect current clamp (factory provided). It stores the most significant data until the next reading by the CU. All data are time stamped.</p>	 <p>Figure 3: IDAM</p>
<p>BATTMASTER® Application Software: Used to configure and monitor the system using an USB or Ethernet connection. It consists of a user friendly GUI (Graphical User Interface), a data base (DB) and a communication module.</p>	 <p>Figure 4: Application screen</p>

A typical system is composed by one **CU**, one **IDAM** for each string of batteries and one **DAM** for each battery. A simple system composed of only one string of batteries is shown below. Each **CU** supports up to **1024 (50 for lite version) DAMs** and **64 IDAMs**.









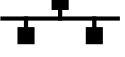
	CU		IDAM		DAM
	Battery		PC		Mobile phone
	RF link		USB		10/100Mb Ethernet

Table 1: Symbols legend

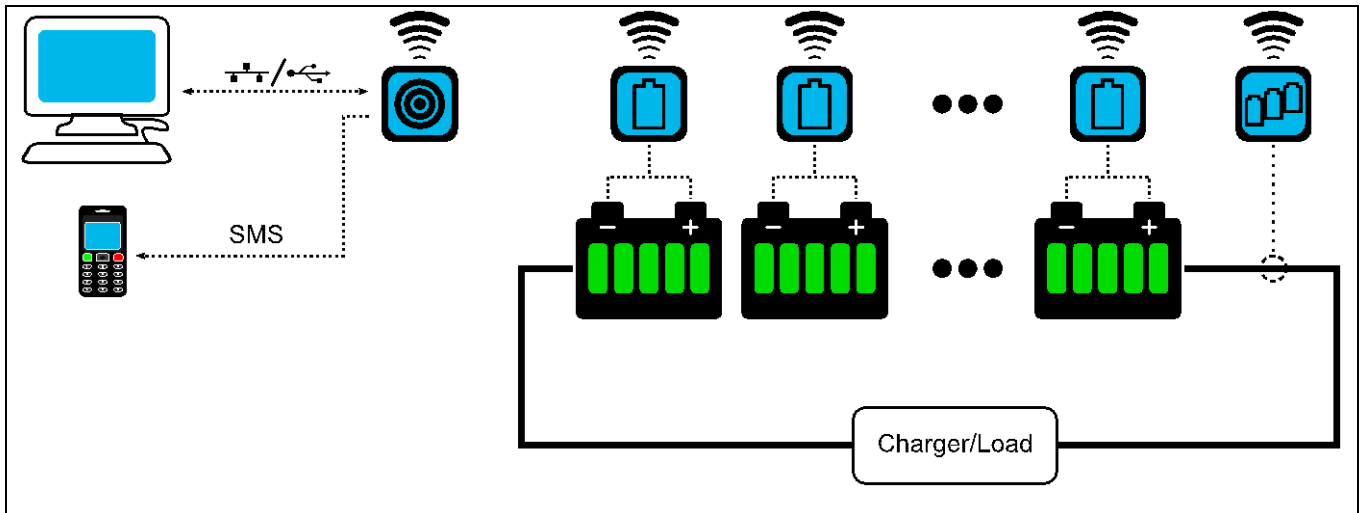


Figure 5: Typical configuration

4 Features and benefits

- ▶ Increases safety and reliability for critical applications
- ▶ Reduces the maintenance costs
- ▶ Increases battery lifespan
- ▶ Provides consistent information useful for battery life prediction
- ▶ Eases the installation and operation
- ▶ Allows integration with other systems
- ▶ Ethernet connectivity allows remote monitoring
- ▶ Allows automatic SMS and E-Mail notifications
- ▶ It is customizable for other parameters logging (i.e. pressure, humidity, etc.)

5 Functional description

5.1 Measured parameters

Each **DAM** continuously measures the following battery parameters:

- ▶ **Voltage:** Sampling rate of 10 ms.
- ▶ **Temperature:** Sampling rate of 10 ms.
- ▶ **Internal resistance (Ri):** Periodically, at 1...168h interval, user settable.

The **IDAM** continuously measures for each string of batteries:

- ▶ **Current:** charge or discharge, sampling rate of 10 ms.
- ▶ **Discharge cycles:** see §5.5.

5.2 Alarms and events

Battery parameters values that are exceeding specific thresholds (user settable) are triggering **alarms** (e.g. over/under voltage, over/under temperature, etc).

The **events** are all the situations that produce a change of the system status (e.g. power on, communication errors, etc).

Alarms and **events** are always *time stamped*.

See also §9.

5.3 Most significant data concept and acquisition intervals

By using a filtering algorithm, the *most significant values* (**minimum, maximum, average voltage and temperature, last R_i measured value, discharge cycles and out of limit voltage, temperature alarms**) of all logged data within the *Acquisition Interval (AI)* are stored in the **DAM** memory and transmitted to the **CU** periodically.

The user can set an *Acquisition Interval (AI)*. *AI* is the interval between **2 data uploads** by the **DAMs** to the **CU**. After uploading the data, the **DAMs** memory is erased and a new set of significant data is built for the following upload.

The minimum recommended value for AI is **1h**, because the batteries are slowly changing systems and there is no need of overloading the database with repetitive information. The minimum *AI* value is limited automatically by the system in proportion with the number of batteries. The system guarantees that no significant data will be lost, independently of the *AI* value.

In case of an alarm the **DAM** sends the relevant data immediately, without waiting for the pre-set *AI* timing.

5.4 Internal resistance measurement

Battery internal resistance (R_i) is measured periodically by means of a controlled AC load present in the DAM. *R_i sampling interval* represents the time between 2 R_i measures (user settable). R_i measures starts only if the specific battery is not in an alarm status and it is fully charged.

5.5 Discharge cycle count

A discharge cycle is counted if the string discharge current is higher than the threshold current set for a time longer than the threshold time set. The *Thresholds* are set in the *String* configuration as explained in §7.4.1.

5.6 User Interface

The **BATTMASTER**® software application allows the user, by means of a friendly graphical interface to:

- ▶ Install and configure the system.
- ▶ View real time system status/measures
- ▶ Organize the collected data in a database and retrieve it in the SD card for further analysis.
- ▶ View alarms/events logs.
- ▶ Export data in spreadsheets and graphs.
- ▶ Execute various zoom/pan operations, set the graphical parameters.
- ▶ Set up communication parameters.



BATTMASTER® software uses the port *TCP 52000* (CU acting as the server). If the user PC is not on the same LAN as the CU you may require opening this port on your firewall/router. Contact your system administrator if necessary.

5.7 Data storage organization

The data can be stored in 2 different modes:

1. **Offline:** The standard logged data is stored in the SD card. When a PC (with the **BATTMASTER** application running) is connected to the CU, the data can be uploaded from the SD card and stored in the PC database (see §8.4).
2. **Online:** In this mode, with a PC connected to the CU and the application running, the logged data is continuously stored to the PC database **and** to the SD card (see §8.3).



Use only the SD card provided with the CU kit.

The oldest data is deleted if the SD card becomes full.

5.8 Notifications

The user can configure the system to automatically send *E-Mail* and *SMS notifications* in case of an alarm or event. Up to **2 E-Mail addresses** and **3 cell phones numbers** for SMS can be configured. See §9 for a list of notifications.

The 2 images below show an example of the E-Mail and SMS received. In both cases the following information is included in the message:

- ▶ The time and date at which the event occurred.
- ▶ The type of device on which the event occurred (CU, IDAM or DAM).
- ▶ The position of the device in the system (e.g. 2.4 means the 4th battery on the 2nd string).
- ▶ The ID of the device on which the event occurred.
- ▶ The name of the event occurred.
- ▶ The value (if any) associated with the event.

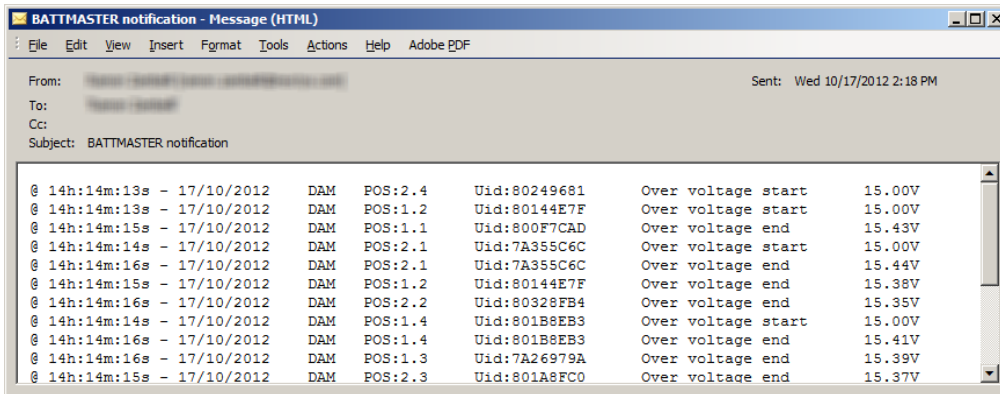



Figure 6: E-Mail



Figure 7:SMS

5.9 Web server

Any CU can be remotely accessed using a web browser, assuming there is a LAN / Internet connection available at the system location and that the LAN access is allowed from the outside world. Insert the *CU IP address* (or name if a *DNS* is configured) on the address bar. On the web application, the user can monitor the actual status of the system. Use the  button to show/hide the navigation menu.

The web server files are stored in the SD card provided with the CU kit. It is therefore necessary that the SD card is inserted to the CU for the web server to work.

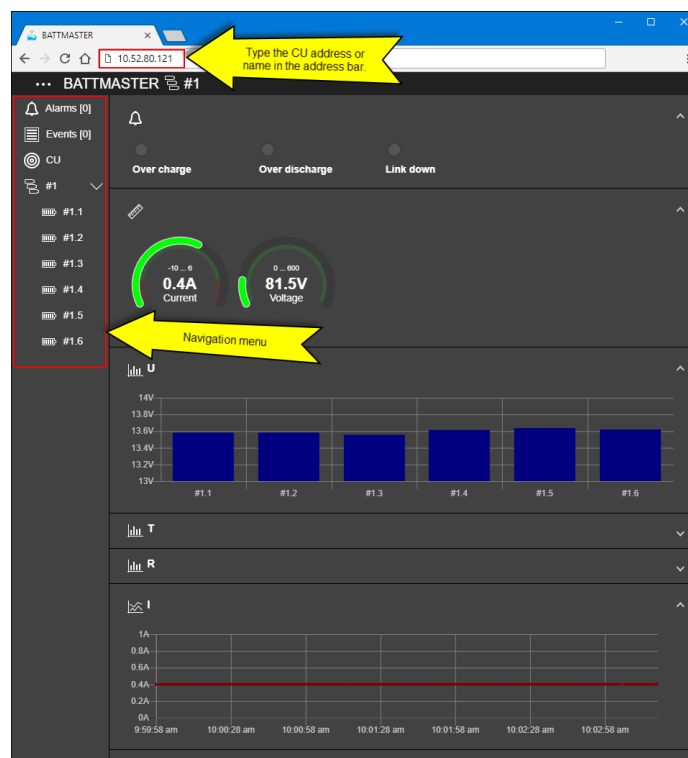


Figure 8: Web monitoring using Chrome browser



The CU web server uses the ports *TCP 80*. If the user PC is not on the same LAN as the CU you may require opening the port on your firewall/router. Contact your system administrator if necessary.

5.10 Database

During installation of BATTMASTER® software an instance of PostgreSQL on TCP port 5432 is installed on the PC. This instance is used by default.

Advanced user may want to use other databases type or connect to remote databases, BATTMASTER® supports the following databases engines through JDBC:

- ▶ **PosgreSQL** with JDBC driver "*jdbc:postgresql*" (<http://www.postgresql.org>)
- ▶ **MySQL** with JDBC driver "*jdbc:mysql*" (<http://www.mysql.com/>)
- ▶ **HyperSQL** with JDBC driver "*jdbc:hsqldb*" (<http://hsqldb.org>)
- ▶ **H2** with JDBC driver "*jdbc:h2*" (<http://www.h2database.com>)
- ▶ **Derby** with JDBC driver "*jdbc:derby*" (<http://db.apache.org/derby>)

User can define one or more alternative JDBC connection adding a file called "config.json" in the BATTMASTER® installation folder. For example, a configuration file with two databases (first is the default localhost PostgreSQL server and the second a remote MySQL server) would be:

```
{
  "databases": [
    {
      "dbName": "Localhost PostgreSQL",
      "dbConnectionString": "jdbc:postgresql://localhost/battmaster",
      "dbUser": "bm",
      "dbPass": "1234"
    }
    {
      "dbName": "Remote MySQL",
      "dbConnectionString": "jdbc:mysql://remote-server-name",
      "dbUser": "bm",
      "dbPass": "1234"
    }
  ]
}
```

Where:

- ▶ **dbName:** User friendly name shown on the startup dialog (see below)
- ▶ **dbConnectionString:** JDBC connection string. Please refer to specific database documentation.
- ▶ **dbUser:** User used for login authentication
- ▶ **dbPass:** Password used for login authentication

By default most database servers don't allow remote connection. For example to allow remote connection to PostgreSQL after the default installation user must add the following lines to "pg_hba.conf" file found in the "\${postgresql-installation-folder}/data" (given your subnet is 192.168.1.1/255.255.255.0):

#	TYPE	DATABASE	USER	ADDRESS	METHOD
	host	all	all	192.168.1.1/24	md5

Please see <http://www.postgresql.org/docs/9.4/static/auth-pg-hba-conf.html> for more details about PostgreSQL "pg_hba.conf" file.

For other database types please refer to the corresponding documentation.

In case one or more databases are defined in the file, at startup the application asks the user to select which database to use, as shown on the image below.

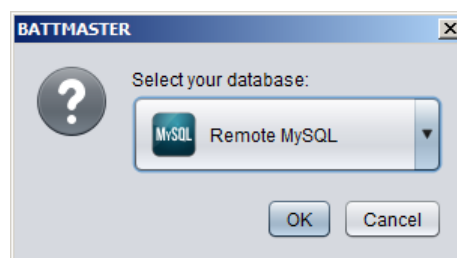


Figure 9: Database selection

Select the database from the dropdown list and then click OK to use the alternate server or click cancel to use the default instance.

5.11 Real Time Logging

Measures from IDAM and DAM is collected once per Acquisition interval (see §5.3) by default. Sometimes is useful to increase the sampling rate (for example to have a finer view of batteries discharge during UPS test). User can increase sampling rate enabling Real Time Logging. There are 4 different ways to enable RTL:

- ▶ **“Start RTL” button on BATTMASTER® software (§8.3):** When RTL is enabled from the application the RTL data is sent to the PC but not stored on the SD card. User can save this data on the PC database by using the “Start save to database” button.
- ▶ **Digital input 1:** When RTL is enabled using this method the RTL data is saved to the SD card automatically.
- ▶ **Modbus/TCP:** RTL can be enabled writing 1 to the Modbus coil at address 0x5000. To save RTL data to SD card the user must write 1 to the Modbus coil at address 0x5001.
- ▶ **Automatic RTL on IDAM current:** In case the string current exceed a user settable value. RTL is started on all sensors attached to the string. Once the current falls below the threshold RTL will stop after a time specified by the user (see §7.4.1).

5.12 Digital I/O

CU as 2 digital input and 2 relay contact. The following functions are implemented:

- ▶ **Input 1:** Enables RTL as explained on §5.11.
- ▶ **Input 2:** Unused, available for future expansion.
- ▶ **Output 1:** Open in case an alarm is present on the system, closed otherwise.
- ▶ **Output 2:** Open in case of an alarm is present on one or more batteries, closed otherwise.

5.13 Sleep

User can put the system to sleep to reduce IDAM and DAM power consumption. During sleep, measures and alarms are stopped. This mode is useful in case the batteries stay long time disconnected from the charger to reduce the discharge. User can wake up the system at any time using the **BATTMASTER®** software.

To put the devices to sleep use must click the “Start sleep” button in the “System configuration tab”, to wake up the click on the “Stop sleep”.

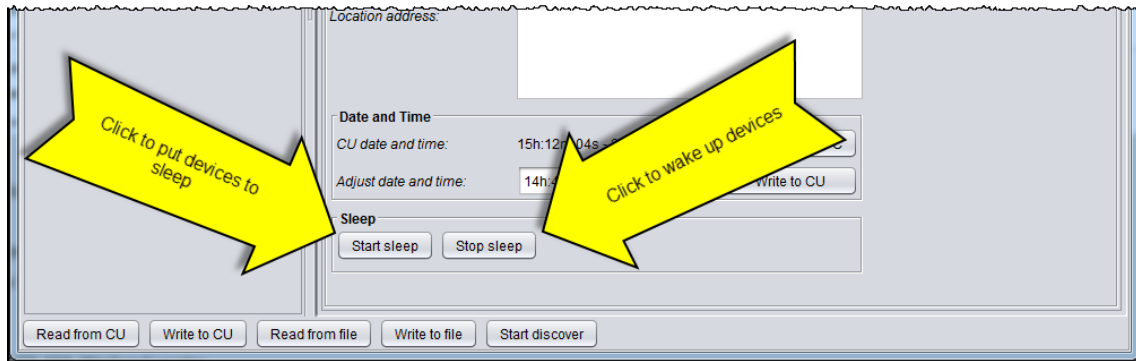


Figure 10: Sleep buttons

5.14 IDAM and DAM firmware update

IDAM and DAM firmware are updatable via radio. Update of a single device takes ~30s. The firmware are bundled into the **BATTMASTER®** software, the bundle version is written on the

5.14.1 Force update of a single device

A single device can be update manually using the device context menu on the “System overview” tree. This update is performed regardless of the firmware version installed is older or newer compared to the bundled version.

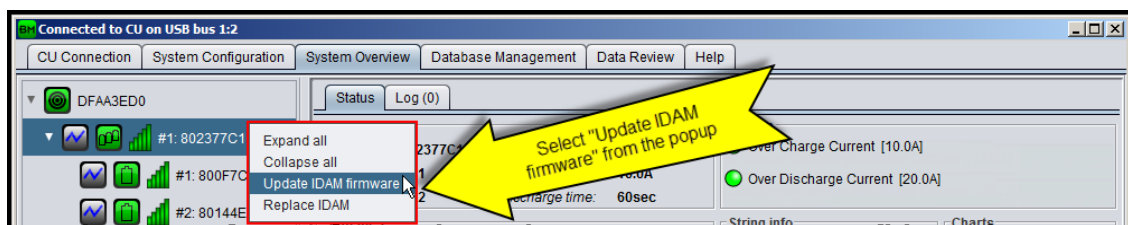


Figure 11: Manually update IDAM firmware

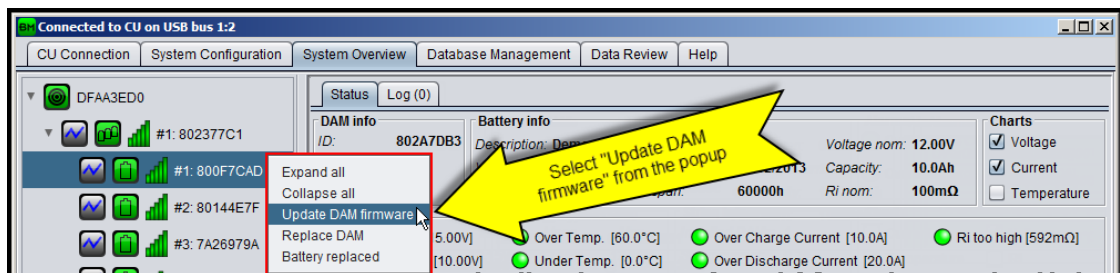


Figure 12: Manually update DAM firmware

5.14.2 Automatic update using **BATTMASTER®** software

This requires a PC **BATTMASTER®** software connected to the CU during all the update procedure. The update rate is ~120devices/hour. To enable this mode the user must select the “Update devices automatically” check box in the “Help” tab. When the software finds a device with an older firmware version it automatically starts the update.

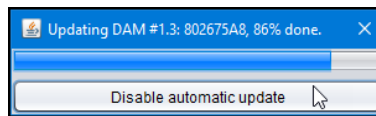


Figure 13: Device update dialog

5.14.3 Automatic background update

The users can launch the background procedure in background. In this mode the CU will automatically interrogate the devices one by one and update the firmware when an old version is found. This update mode is launched with the “Start background update” button in the “Help” tab.

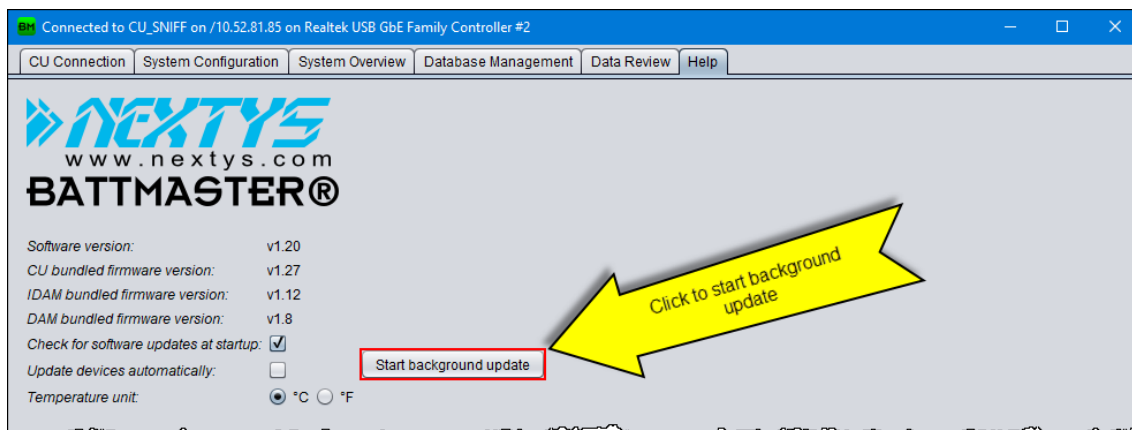


Figure 14: Start background update

After starting the procedure user can disconnect the **BATTMASTER®** software from the CU. User can monitor and/or stop the background update from the “Help” tab as shown below.

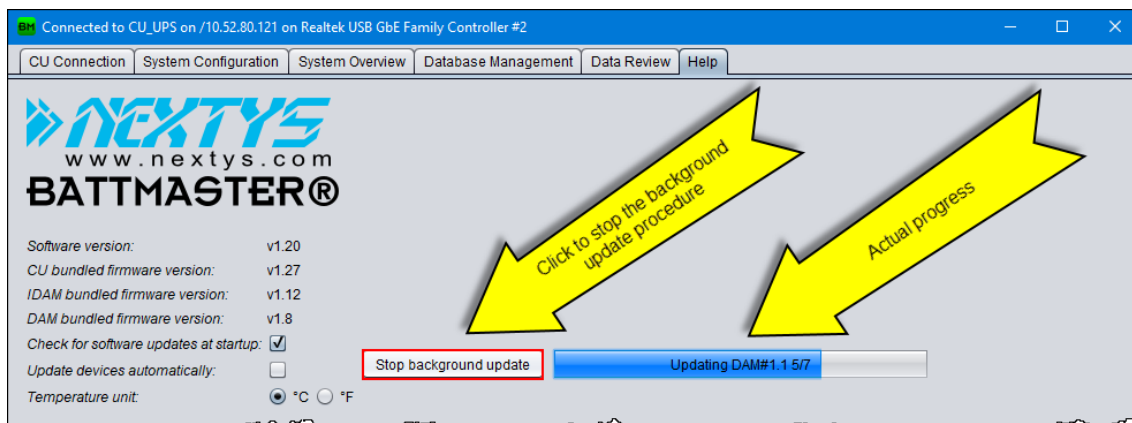


Figure 15: Stop background update

5.15 CU LEDs

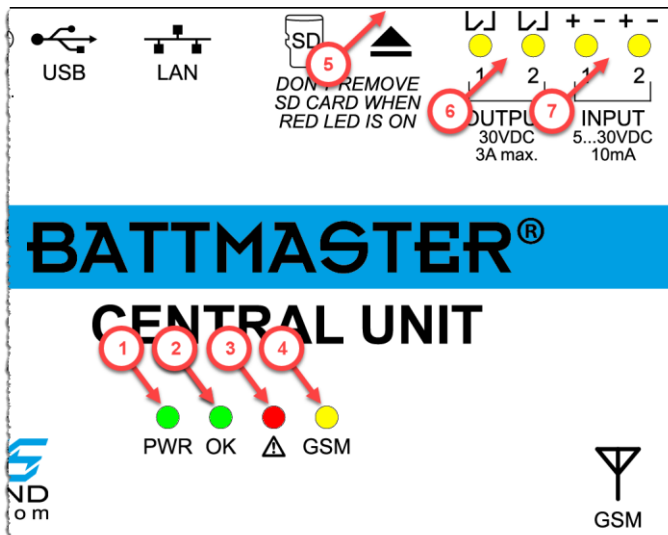


Figure 16: CU LEDs

1. **POWER OK:** ON when device is powered.
2. **OK:** LED is blinking when the CU is communicating with the remote radio devices.
3. **Alarm:** OFF when no alarm is ongoing on the system, blinking at ~1Hz otherwise.
4. **GSM:** blinking at ~1Hz when not registered to the GSM network or at ~0.3Hz when registered.
5. **SD card:** ON when the SD card is in use.
6. **Outputs:** ON when the corresponding output is active.
7. **Inputs:** ON when the corresponding input is active.

5.16 Modbus/TCP

CU can be accessed using Modbus/TCP on port 502. Modbus table is shown on Table 2.

IDAM address is calculated adding the string index minus 1 to the base address of the variable.

For example, to read the current for the String #3:

$$\text{Address} = \text{base} + (\text{IDAM index}) - 1 = 0x1000 + 3 - 1 = 0x1002$$

DAM address is calculated adding the DAM index into the string and the DAM of the previous strings to the base address of the variable minus 1.

For example, in a system with 3 strings with 4 batteries each to read the DAM #3.2 use:

$$\text{Address} = \text{base} + (\text{DAM index}) + (\text{Previous String DAM count}) - 1 = 0x1200 + 2 + 8 - 1 = 0x1209$$

Name	Address	Modbus type	Function code	Description
IDAM current	0x1000...0x103F	Input register	3,4	IDAM measured current in steps of 0.1A
DAM voltage	0x1200...0x15FF	Input register	3,4	DAM measured voltage in steps of 1mV
DAM temperature	0x1600...0x19FF	Input register	3,4	DAM measured temperature in steps of 0.1°C
DAM Ri	0x1A00...0x1DFF	Input register	3,4	DAM measured internal resistance in steps of 0.1Ω
IDAM alarms	0x2000...0x203F	Input register	3,4	Bitfield containing the actual IDAM alarms. Bit0: Over charge current Bit1: Over discharge current
DAM alarms	0x2200...0x25FF	Input register	3,4	Bitfield containing the actual DAM alarms. Bit0: Under voltage Bit1: Over voltage Bit2: Under temperature Bit3: Over temperature Bit4: Ri too high
DAM charge cycles	0x3000...0x33FF	Input register	3,4	Counter of charge cycles
IDAM RTL enable	0x4000...0x403F	Coil	1,2,5,15	Enables RTL for the addressed IDAM
IDAM RF link down	0x4100...0x413F	Discrete input	1,2	Active if the RF link between CU and addressed IDAM is down.
DAM RTL enable	0x4200...0x45FF	Coil	1,2,5,15	Enables RTL for the addressed DAM
DAM RF link down	0x4600...0x49FF	Discrete input	1,2	Active if the RF link between CU and addressed DAM is down.
DAM perform voltage measurement	0x4A00...0x4A39	Coil	3,6,16	Set to 1 to force retrieve a new voltage measurement from the DAM. The flag clears to 0 automatically when the new voltage measurement is retrieved.
DAM perform Ri measurement	0x4A40...0x4A7F	Coil	3,6,16	Set to 1 to start Ri measurement on the DAM. The flag clears to 0 automatically when the new Ri measurement is retrieved.
Enable RTL	0x5000	Coil	1,2,5,15	Enable Real Time Logging. Coil resets on

				Modbus disconnection.
Write RTL data to SD	0x5001	Coil	1,2,5,15	When active the Real Time Data is saved to the SD card. Coil resets on Modbus disconnection.
Perform voltage measurement on all DAM	0x5002	Coil	1,2,5,15	On write to 1, all the “DAM perform voltage measurement” flag are set to 1.
Perform Ri on all DAM	0x5003	Coil	1,2,5,15	On write to 1, all the “DAM perform Ri measurement” flag are set to 1.
System alarm	0x6000	Discrete input	1,2	At least one alarm is ongoing on the system.
Battery alarm	0x6001	Discrete input	1,2	At least one alarm is ongoing on the batteries.

Table 2: Modbus table

6 Installation

6.1 CU

The following connection sockets are available on the CU (see Figure 17):

- ▶ **I/O connector:** Provided with 2 *INPUTS* (opto isolated) and 2 *OUTPUTS* (dry contacts). *Out 1* is closed in case no alarm is in progress. In case of alarm the contact opens. The other I/Os are reserved for future use.
- ▶ **SD card eject button:** Must be pressed before removing the SD card if the CU is powered. After pressing the button the red LED on top of the button turns OFF indicating that the SD card can be removed safely.
- ▶ **SD card slot:** Hosts the SD card (to be inserted following the polarity shown on the label).
- ▶ **10/100Mb Ethernet:** Used to connect the Ethernet cable to put the system in the network.
- ▶ **USB port:** Used to connect the USB cable from the PC to the CU. It can provide power to the CU as an alternate to the wall mount power adapter (provided).



Important: in case of use of the USB power only (no external power supply connected) the backup function (see below) is not active.

- ▶ **DC socket:** Used to connect the wall mount power adapter (provided). The jack insertion also activates the battery backup function (i.e. in case of power failure the CU is able to run from the internal NiMH batteries for ~1.5h).
- ▶ **SIM card socket:** Used for hosting the SIM card for the GSM communication.
- ▶ **GSM antenna socket:** the socket standard is MMCX and it used to connect an external antenna in case of poor signal strength. A standard GSM antenna is already present inside the CU.

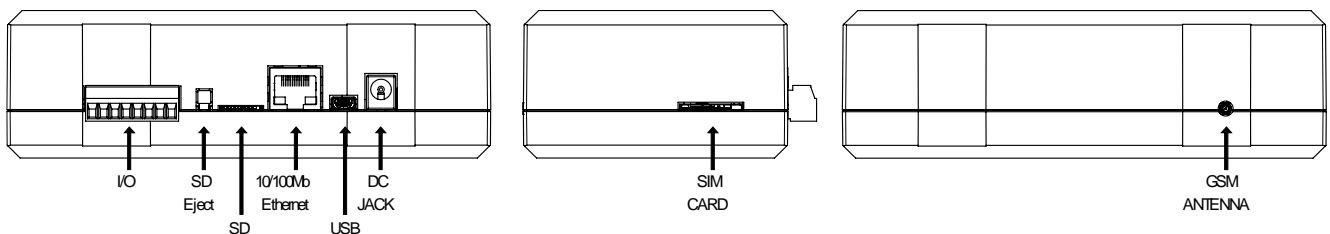


Figure 17: CU connection and sockets

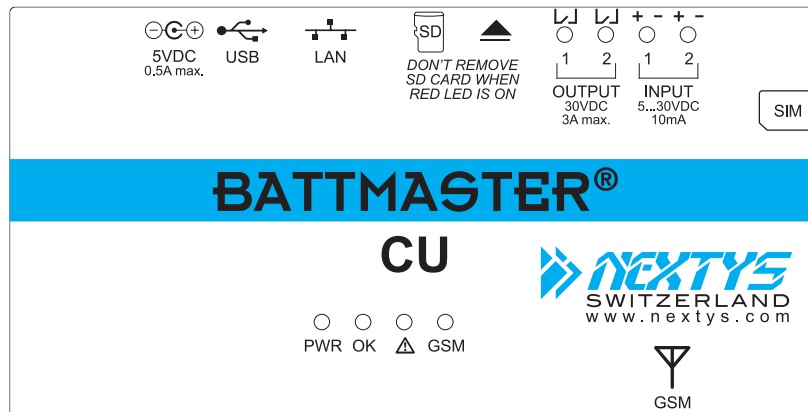


Figure 18: CU top label

6.2 IDAM

The IDAM must be installed as follows:

1. Select the current range on the current transducer clamp.
2. Place the clamp on the conductor connecting the batteries string following the right polarity as shown on images below. Measured current is positive while charging and negative while discharging.
3. Plug the power adapter connector to the IDAM as shown on Figure 21. The connector has a key to prevent reverse insertion, don't force the connector in its socket! Carefully check that the plug is securely connected.
4. Plug the current clamp to the IDAM as shown on Figure 21. The connector has a key to prevent reverse insertion, don't force the connector in its socket. Carefully check that the plug is securely connected.

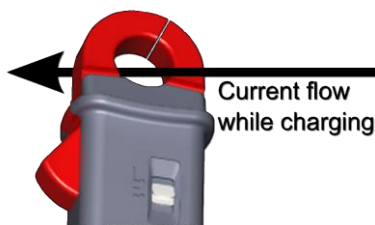


Figure 19: 300A clamp polarity



Figure 20:600A clamp polarity



Figure 21: IDAM connections

5. Plug the provided wall mount power adapter in the AC power socket. In case of automatic configuration perform this operation later as specified in §7.4.3.

6. Calibrate clamp's "0" using **BATTMASTER**® software. Making sure no current is flowing on the string, right click on the string icon in "System overview" tab and select "Calibrate zero current". This operation must be performed every time the clamp is removed or turned ON.

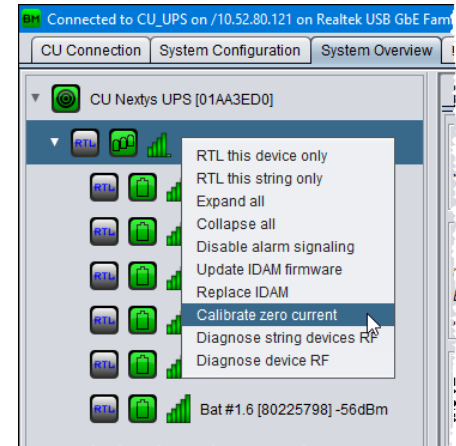


Figure 22: Calibrate zero current

6.3 DAM

⚠ DANGER

Due to the potentially high voltages and currents present in the system the DAM installation requires extreme care. The installation shall be performed only by a qualified and trained technician applying all the relevant electrical safety measures. Every DAM must be securely connected using the provided cables only to a single battery respecting the correct polarity. When many batteries are connected in series to form strings the total voltage can reach dangerous and potentially fatal levels. The batteries must be disconnected from the charger and from the load during DAM installation process. Wear complete eye protection and protective clothing.

⚠ CAUTION

To avoid damage the DAM and voiding the warranty, ensure the voltage of the battery you are using matches the voltage rating of the DAM you are using.

⚠ CAUTION

Don't place the DAM on top of the battery valve, because in case of battery leakage the DAM may be damaged by the acid.

The DAM is connected to the battery using the one of the cables shown below. The customer may order the appropriate type of cable according to its requirements (special configurations are possible on request).

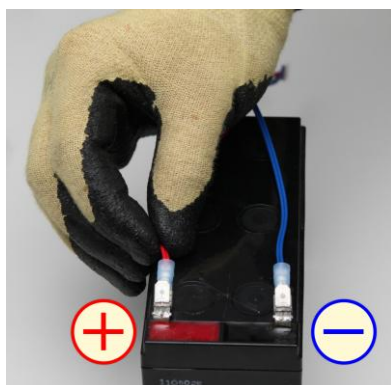
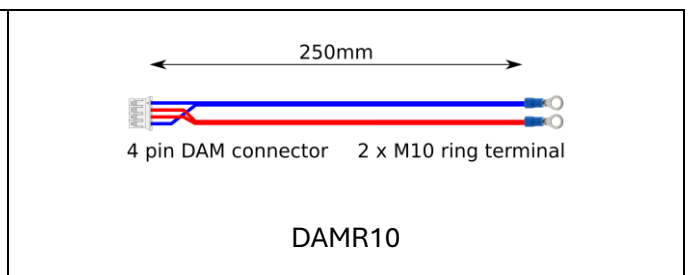
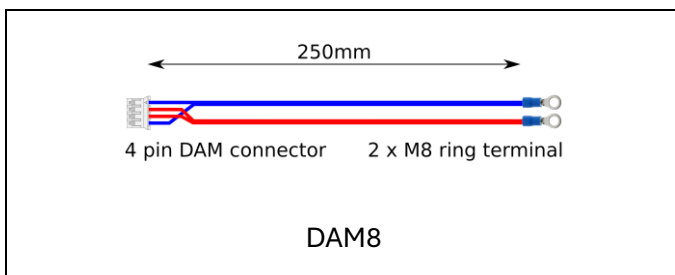
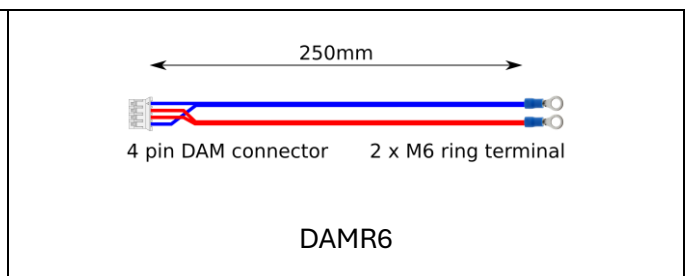
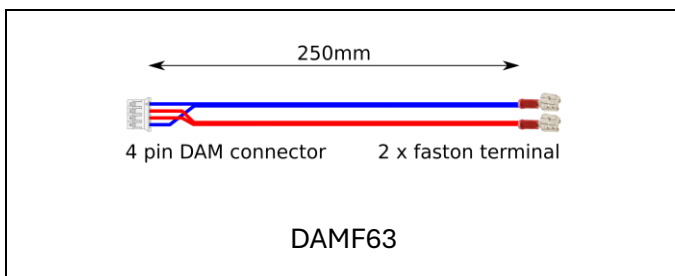
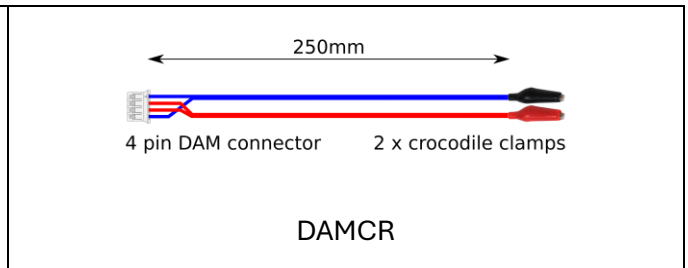


Figure 23: Cable connection to the battery



Figure 24: Cable connection to the DAM

The DAM must be installed as follows (use of insulating gloves is strongly recommended):

1. Fix the DAM on the battery using the provided VELCRO tape placing the hooks on the battery and the loops on the DAM. The DAM includes an internal temperature sensor to sense the battery ambient temperature. The temperature measured with the internal sensor can be slightly affected by the internal heating generated by the circuitry. An external temperature sensor (provided by Nextys) allowing for a temperature measurement in contact with the battery is available as an option.
2. Securely connect the DAM cable to the battery using the provided terminals. Although the DAM is protected against reverse polarity connection please **respect the polarity**. The **red** cable must be connected to the battery positive (+) terminal; the **blue** cable must be connected to the battery negative (-) terminal.
3. Connect the battery cable to the DAM cable receptacle as shown in Figure 24. The connector has a key to prevent reverse insertion, don't force the connector in its socket! Carefully check that the plug is securely connected. In case of automatic configuration perform this operation later as specified in §7.4.4.



Don't leave the DAM connected to the battery if the battery is disconnected from the charger or out of use. Although the DAM current consumption is very low it will discharge the battery in the long term.

6.4 BATTMASTER® software

Run “*SETUP-BATTMASTER-XX.exe*” (where XX is replaced with the release number) and follow the instructions on the screen until the end of the installation process. The installer file can be found in the CD provided with the CU kit or it can be downloaded on **NEXTYS** website, www.nextys.com.

BATTMASTER® application can be installed on any PC running Windows 7 (32 and 64bits), Windows 8 (32 and 64bits) or Windows 10 (32 and 64bits).

7 Configuration

The system must be configured using the **BATTMASTER®** PC software through the following procedure.

7.1 Prerequisites

1. **BATTMASTER®** PC software should be installed on the computer (see §6.4). The installer is provided on the CD accompanying the CU or it can be downloaded from www.nextys.com.
2. The CU must be turned ON and connected either with USB or LAN to the computer running the **BATTMASTER®** PC software (see §6.1).
3. Desired voltages, current and temperatures alarm thresholds for the monitored batteries should be known (refer to the battery manufacturer datasheet or the application specification).

7.2 Connect to CU

1. Launch the **BATTMASTER®** application.
2. At start-up the CUs connected to the computer are discovered and shown in the “**CU connection**” tab as shown on Figure 25. Ethernet discovery uses broadcast packets and therefore only CUs present on the same network (LAN) are automatically discovered. If the CU is not discovered automatically user should check the USB and / or LAN connection and click on the “**Discover**” button on the bottom of the page. On Figure 25 the same CU is discovered twice because it is connected on same time with USB and LAN to the same PC.

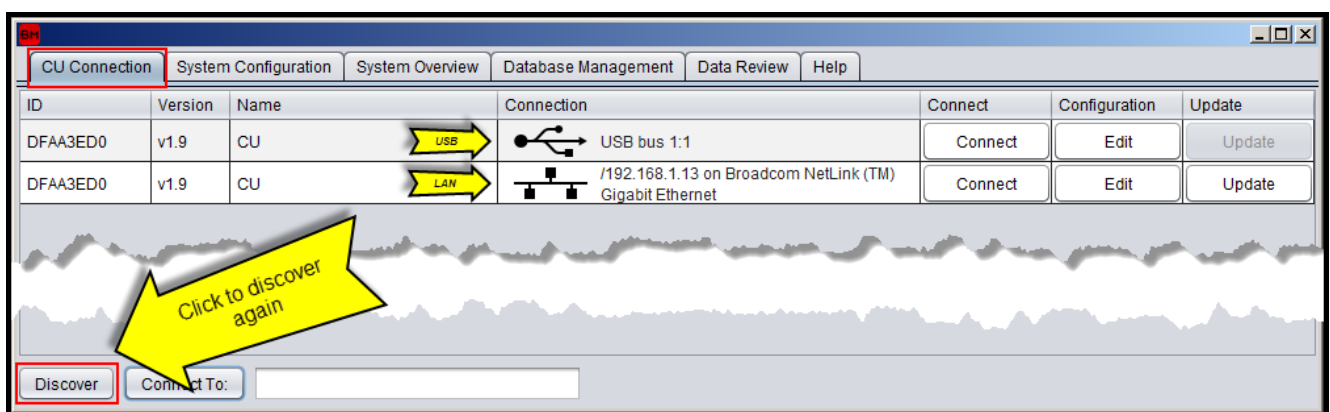


Figure 25: CU connection discovered devices

- The CU is shipped by default with a dynamic IP address (DHCP) which should fit most of the uses. In case the CU must be run with a different setting, the user can click on the **“Edit”** button to open the TCP/IP configuration dialog as shown in Figure 26. Insert the desired values in the dialog and click on **“Write to device”** button to store the new setting in the CU.

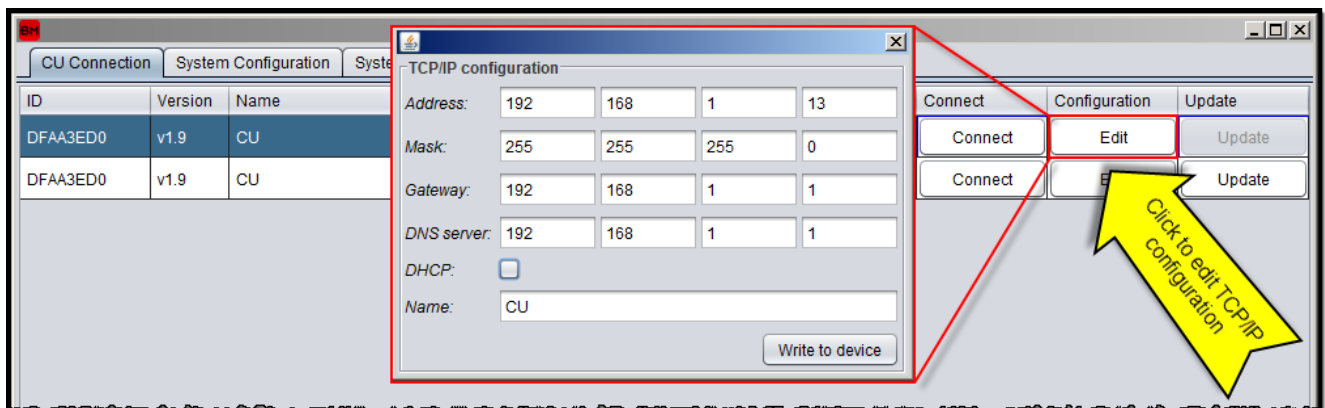


Figure 26: CU connection TCP/IP configuration

- Connect to the CU pressing the **“Connect”** button. Once connected the windows title and icon changes as shown on Figure 27. Ethernet discovery only works if the CU and the PC are on the same LAN. In case the CU is not discoverable because not on the same LAN, the user must write the public address or name on the field on the page bottom and click on the **“Connect to:”** button.

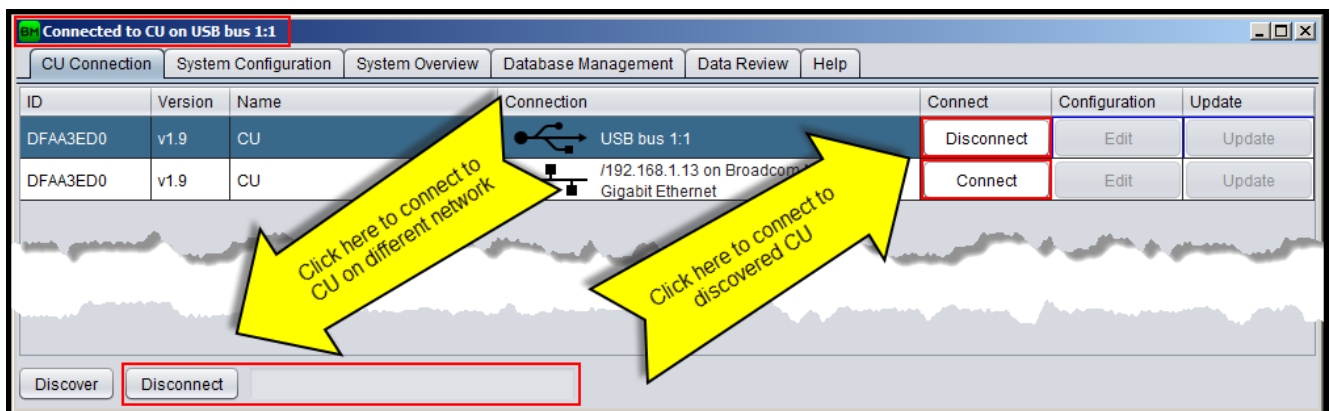


Figure 27: CU connection

7.3 System configuration

5. Open the “System configuration” tab as shown on Figure 28.

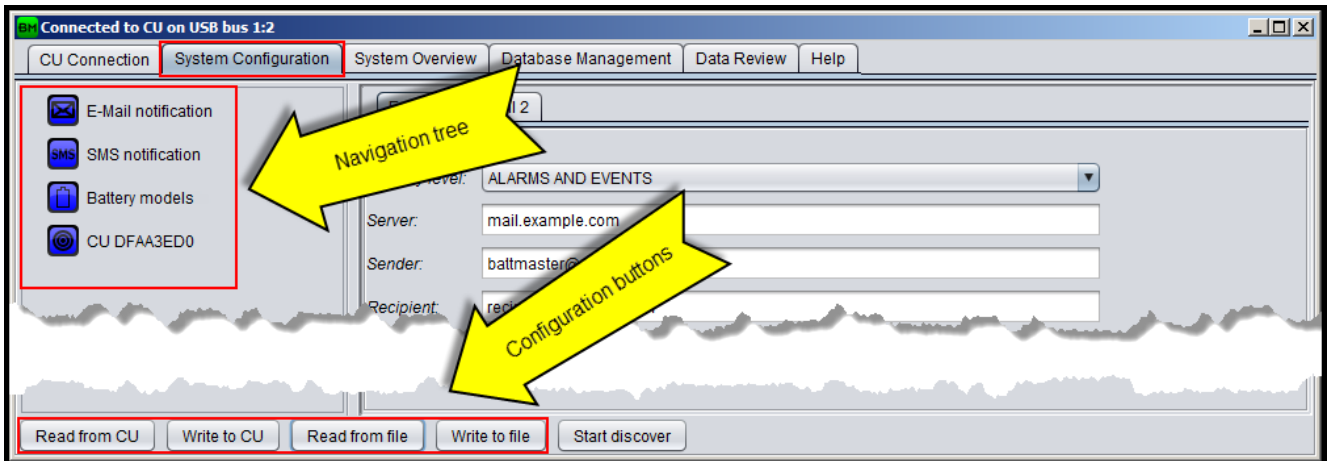


Figure 28: System setup

7.3.1 E-Mail notification

6. Select E-Mail notification as shown on Figure 29.

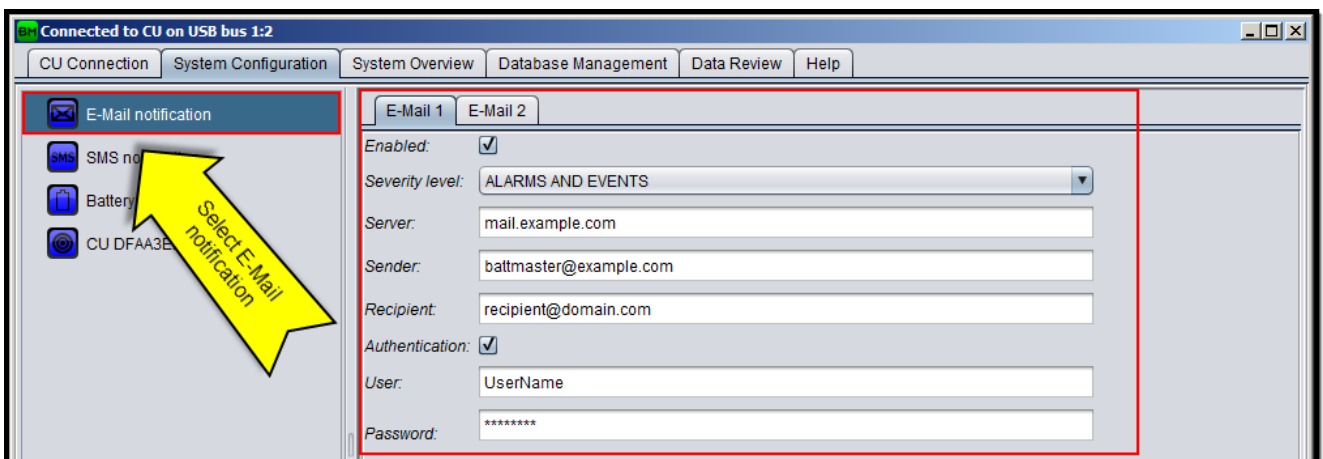


Figure 29: E-Mail notification configuration

7. Up to 2 E-Mail recipients can be enabled. An SMTP E-Mail account must be setup by a provider of your choice. Select the corresponding E-Mail tab and fill in the following fields:
 - ▶ **Enabled:** Tick the checkbox to enable the E-Mail notification. *Default value:* disabled.
 - ▶ **Severity level:** Select “ALARMS AND EVENTS” if you want the recipient to receive notifications for both *alarms* and *events*. Select “ALARMS ONLY” to send only notification in case of alarm. For a list of alarms and event see §9. *Default value:* alarms and events.
 - ▶ **Server:** Enter the mail sever SMTP address. *Default value:* empty.
 - ▶ **Sender:** Enter the sender E-Mail address. *Default value:* empty.
 - ▶ **Recipient:** Enter recipient’s E-Mail address. *Default value:* empty.
 - ▶ **Authentication:** tick this checkbox if the SMTP mail server requires an authentication. *Default value:* ticked.
 - ▶ **User:** Enter the user name used for the authentication. *Default value:* empty.
 - ▶ **Password:** Enter the password used for the authentication. *Default value:* empty.

7.3.2 SMS notification

8. Select SMS notification as shown on Figure 30.

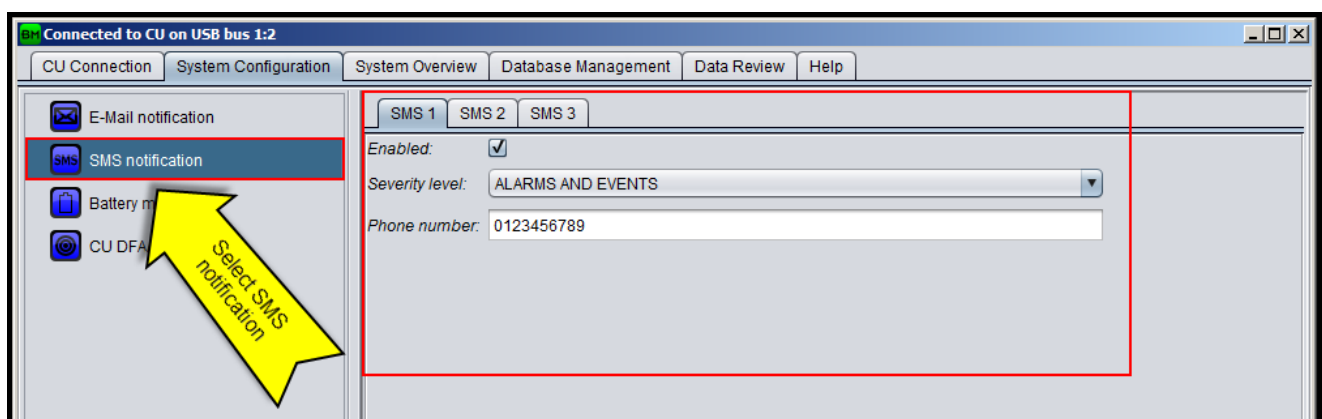
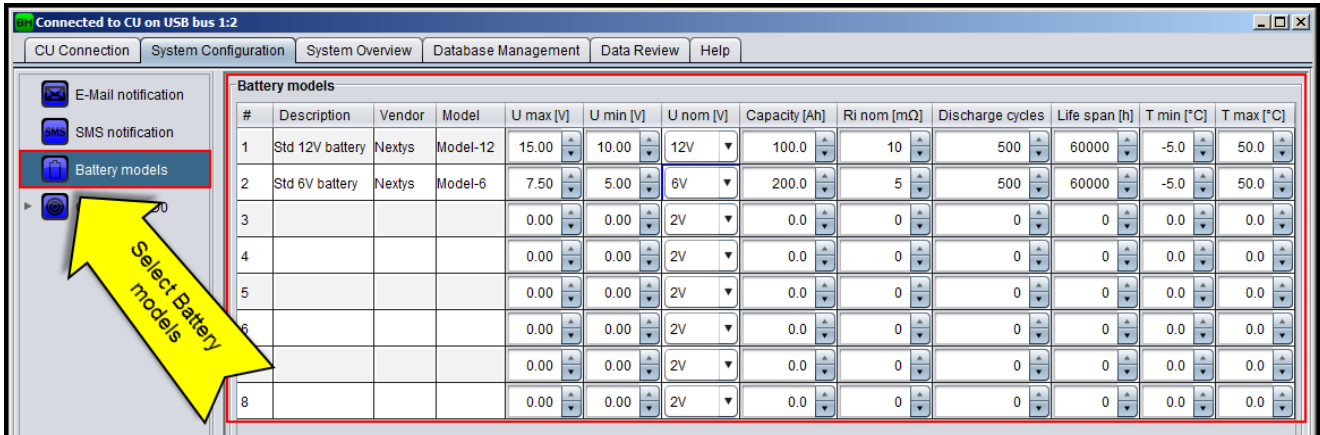


Figure 30: SMS notification configuration

9. Up to 2 SMS recipients can be enabled. Select the corresponding SMS tab and fill in the following fields:
 - ▶ **Enabled:** Tick the checkbox to enable the SMS notification. *Default value:* disabled.
 - ▶ **Severity level:** Select “ALARMS AND EVENTS” if you want the recipient to receive notifications for both *alarms* and *events*. Select “ALARMS ONLY” to send only notifications in case of alarm. For a list of alarms and events see §9. *Default value:* alarms and events.
 - ▶ **Phone number:** Enter the SMS recipient’s phone number. *Default value:* empty.

7.3.3 Battery models configuration

10. Select Battery models as shown on Figure 31.



#	Description	Vendor	Model	U max [V]	U min [V]	U nom [V]	Capacity [Ah]	Ri nom [mΩ]	Discharge cycles	Life span [h]	T min [°C]	T max [°C]
1	Std 12V battery	Nextys	Model-12	15.00	10.00	12V	100.0	10	500	60000	-5.0	50.0
2	Std 6V battery	Nextys	Model-6	7.50	5.00	6V	200.0	5	500	60000	-5.0	50.0
3				0.00	0.00	2V	0.0	0	0	0	0.0	0.0
4				0.00	0.00	2V	0.0	0	0	0	0.0	0.0
5				0.00	0.00	2V	0.0	0	0	0	0.0	0.0
6				0.00	0.00	2V	0.0	0	0	0	0.0	0.0
7				0.00	0.00	2V	0.0	0	0	0	0.0	0.0
8				0.00	0.00	2V	0.0	0	0	0	0.0	0.0

Figure 31: Battery's models configuration

11. Up to 8 different battery models can be described for a system, one for each row in the table (see Figure 31). Fill in the following fields for every different battery model:

- ▶ **Description:** Description of the battery. *Default value:* empty.
- ▶ **Vendor:** Battery's vendor name. *Default value:* empty.
- ▶ **Model:** Battery's vendor model. *Default value:* empty.
- ▶ **U max [V]:** Maximum battery voltage threshold. An alarm is generated if the voltage measured on the battery is exceeding this value. *Default value:* 15Volts.
- ▶ **U min [V]:** Minimum battery voltage threshold. An alarm is generated if the voltage measured on the battery is lower than this. *Default value:* 10Volts.
- ▶ **U nom [V]:** The battery nominal voltage. Possible choices are 2V, 6V and 12V. *Default value:* 12V.
- ▶ **Capacity [Ah]:** The battery nominal capacity as specified by its datasheet. *Default value:* 100Ah.
- ▶ **Ri nom [mΩ]:** The nominal battery internal resistance as specified by the battery's vendor datasheet. This is a reference only and may differ from the values measured by the system. *Default value:* 10mΩ.
- ▶ **Discharge cycles:** The maximum charge-discharge cycles the battery can withstand as specified by its datasheet. *Default value:* 500.
- ▶ **Life span:** The maximum life span (expressed in h) the battery can withstand as specified by its datasheet. *Default value:* 60000.

- ▶ **T max [°C]:** Maximum battery temperature threshold. An alarm is generated if the temperature measured on the battery is exceeding this value. *Default value:* 50.
- ▶ **T min [°C]:** Minimum battery temperature threshold. An alarm is generated if the temperature measured on the battery is lower than this value. *Default value:* 0.

7.3.4 CU configuration

12. Select the CU as shown on Figure 32.

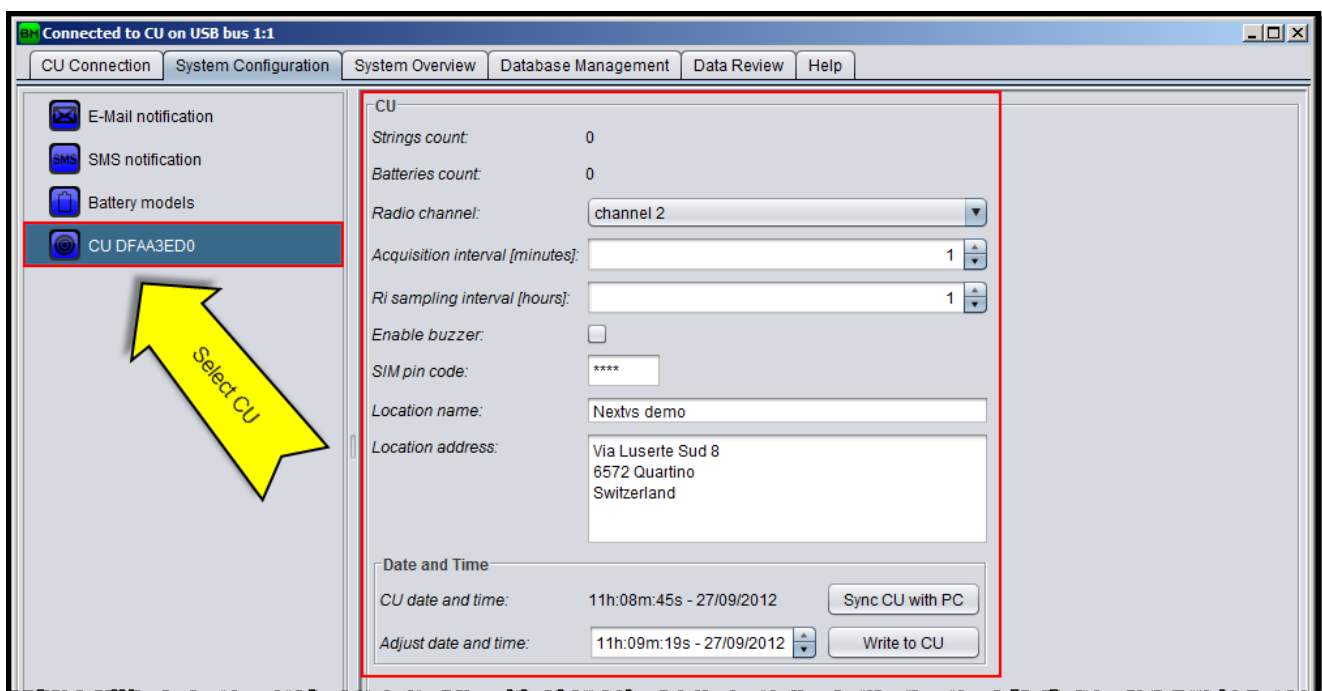


Figure 32: CU configuration

13. Fill in the following fields (strings and batteries count are automatically updated read only fields):

- ▶ **Radio channel:** Choose the desired RF channel for the system. If more than one **BATTMASTER®** system is installed on the same location the user must select a different channel for each system to avoid interference between them. *Default value:* channel 1.
- ▶ **Acquisition interval [minutes]:** The interval between 2 DAM/IDAM measurements acquisitions. *Default value:* 60minutes.
- ▶ **Ri sample interval [hours]:** The interval between 2 batteries internal resistance measurements. *Default value:* 24hours.
- ▶ **Enable buzzer:** Tick the checkbox to activate the acoustic signal in case of alarm. *Default value:* enabled.
- ▶ **SIM pin code:** Insert the GSM SIM card pin code if existing. *Default value:* 0000.

- ▶ **Location name:** (optional) insert the location name. *Default value:* empty.
- ▶ **Location address:** (optional) insert the location address. *Default value:* empty.
- ▶ **Date and Time:** Click on “**Sync CU with PC**” to set the PC date and time to the connected CU, otherwise enter a different date and time inside the spinner control and click on “**Write to CU**” button. *Default value:* N/A.

7.4 Configuring strings and batteries

The user must specify the number of strings and batteries and their layout in the system. Configuration of the strings and batteries can be done in 2 ways, *manual* or *automatic*, as explained below.

Automatic mode is possible only if an IDAM is associated to the string and a DAM to the battery.

At the end of the string and batteries configuration process the tree layout must reflect the layout of the system. As an example on Figure 33 a system with 2 strings each composed of 4 batteries is shown.

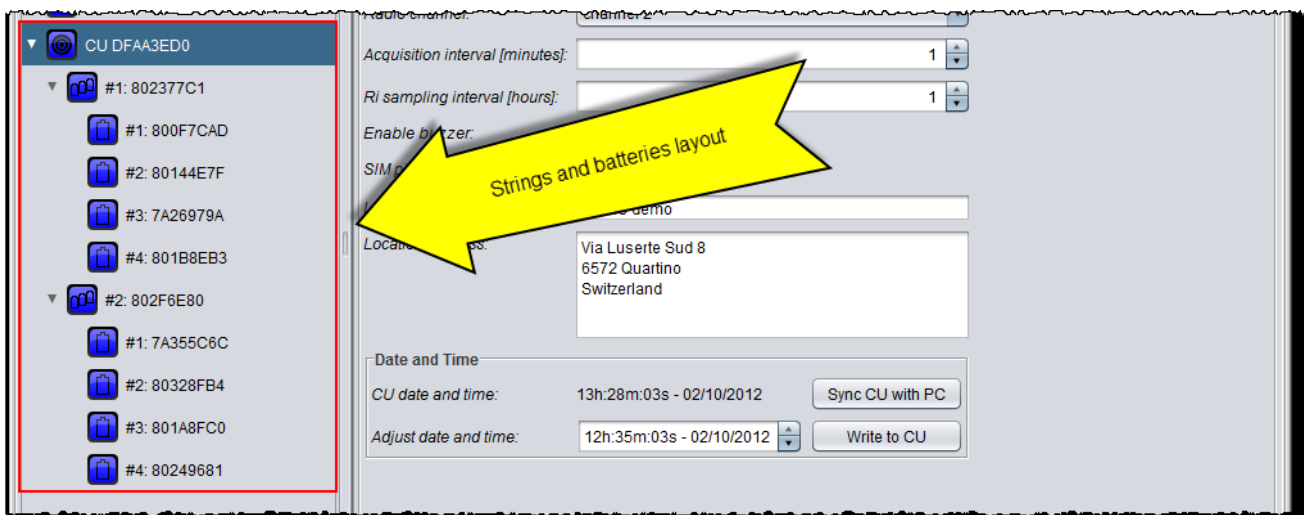


Figure 33: String and batteries layout example

7.4.1 Manual string add-on

1. Right click on the CU icon to open the popup menu and select “**Add string**” as shown on Figure 34.

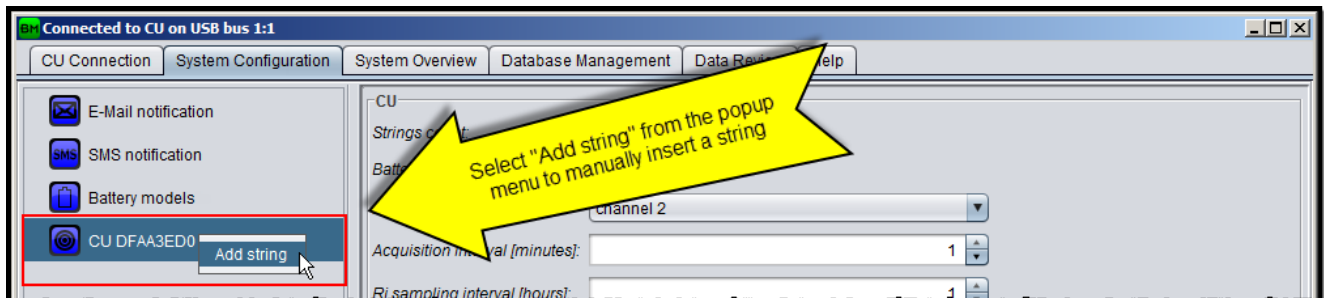


Figure 34: Manually add string

2. Select the added string icon as shown in Figure 35 and fill in the following fields:
 - ▶ **IDAM ID:** Input the IDAM ID. If no IDAM is associated with the string leave “00000000”. In case of *automatic* add-on (see §7.4.3) the ID is automatically filled in.
 - ▶ **Name:** Custom name for the string. The name is displayed on the tree. If empty, the default string name is shown on the tree (String #N). *Default value:* Empty.
 - ▶ **Current clamp range:** Enter the range selected on the current clamp (see §6.2 for more information). *Default value:* ±40A.
 - ▶ **Discharge current [A]:** In conjunction with “Discharge time” defines the discrimination threshold for a discharge cycle (see §5.5 for more details). *Default value:* 5A.
 - ▶ **Discharge time [s]:** In conjunction with “Discharge current” defines the discrimination threshold for a discharge cycle (see §5.5 for more details). *Default value:* 60s.
 - ▶ **Over charge current [A]:** Maximum string charge current threshold. If the current measured on the string is exceeding this value an alarm is generated. *Default value:* 6A.
 - ▶ **Over discharge current [A]:** Maximum string discharge current threshold. If the current measured on the string is exceeding this value an alarm is generated. *Default value:* 15A.
 - ▶ **Automatic RTL current [A]:** Current threshold used to start automatic RTL on the string when measured current is exceeding this value. *Default value:* Disabled.
 - ▶ **Automatic RTL time [sec]:** Time before terminating automatic RTL on the string after the current falls below the detection threshold. *Default value:* 0s.
 - ▶ **Battery voltage variation max [%]:** Every battery voltage is checked against the string voltage average. An alarm is generated in case the difference between the average and the battery voltage exceed this percentage. *Default value:* Disabled.

- ▶ **Battery temperature variation max [°C]:** Every battery temperature is checked against the string temperature average. An alarm is generated in case a battery temperature exceeds the average by this value. *Default value:* Disabled.
- ▶ **Battery Ri variation max [%]:** Every battery Ri is checked against the string Ri average. An alarm is generated in case a battery Ri exceeds the average by this percentage. *Default value:* Disabled.
- ▶ **Default battery model:** Sets the default battery used in this string. This value will be used as default when adding batteries to the string. *Default value:* #1.
- ▶ **Default battery installation date:** Sets the default battery installation date for this string. This value will be used as default when adding batteries to the string. *Default value:* today.
- ▶ **Default battery Ri max:** Sets the default battery Ri max for this string. This value will be used as default when adding batteries to the string. *Default value:* automatic.

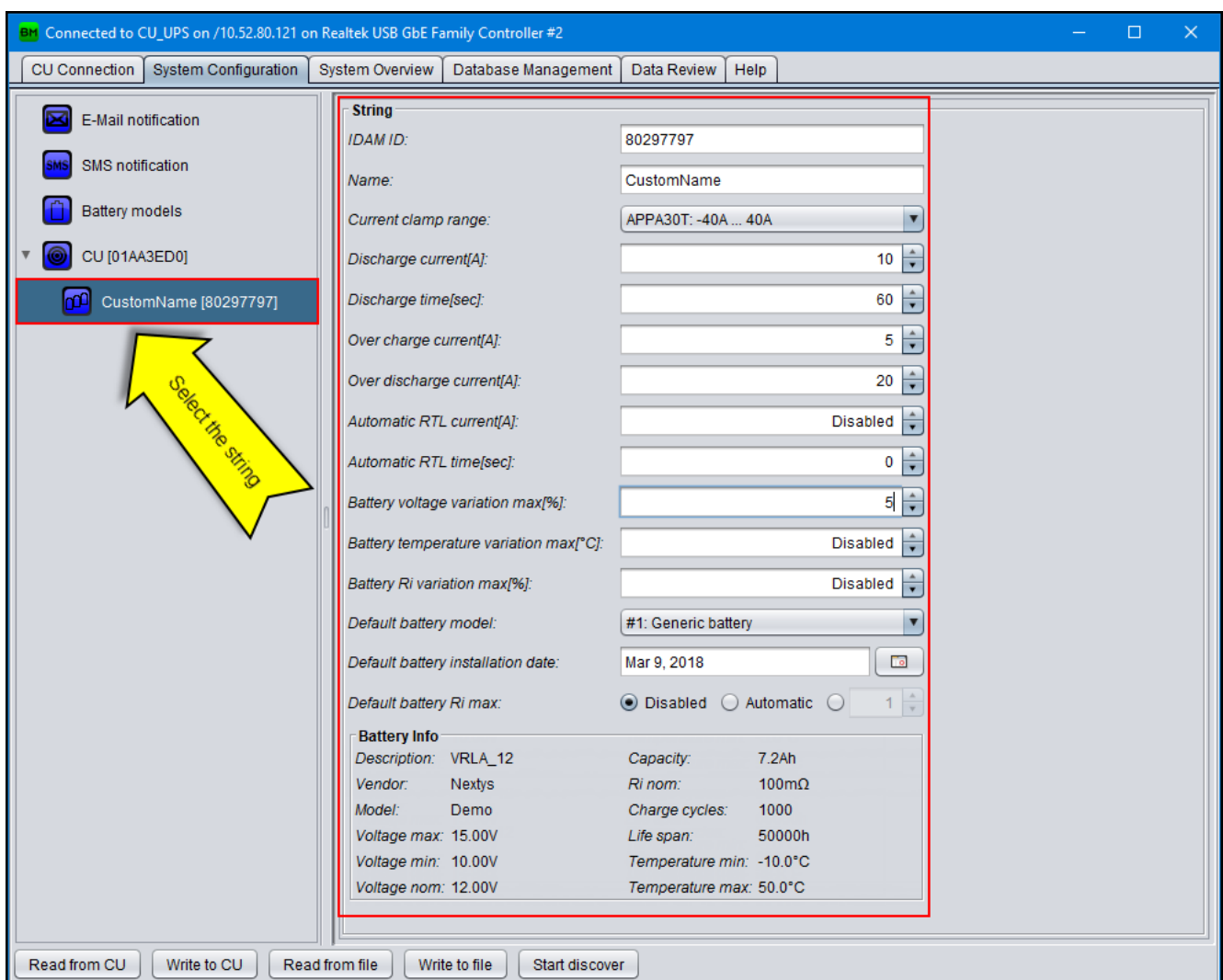


Figure 35: String configuration

7.4.2 Manual battery add-on

1. Right click on the String icon to open the popup menu and select “**Add battery**” as shown on Figure 36.

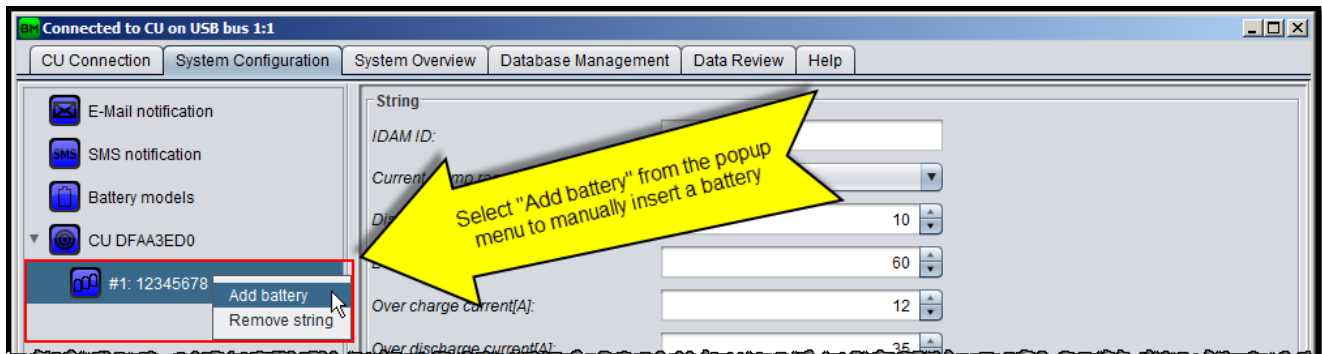


Figure 36: Manually add battery

2. Select the added string icon as shown in Figure 37 and fill in the following fields:
 - ▶ **DAM ID:** Input the DAM ID. If no DAM is associated with the battery leave “00000000”. In case of automatic add-on (see §7.4.4) the ID is automatically filled in.
 - ▶ **Battery installation date:** Input the battery installation date used for the operating time counter. *Default value:* Value filled in the “Default battery installation date” field in the parent string. (see §7.4.1).
 - ▶ **Battery Ri max:** Sets the battery internal resistance alarm threshold. If enabled an alarm is generated if the measured internal resistance is exceeding this value. If automatic is selected the system will set the threshold value automatically.
 - ▶ **Battery model:** Select the battery model from the list. *Default value:* Value filled in the “Default battery model” field in the parent string. (see §7.4.1).

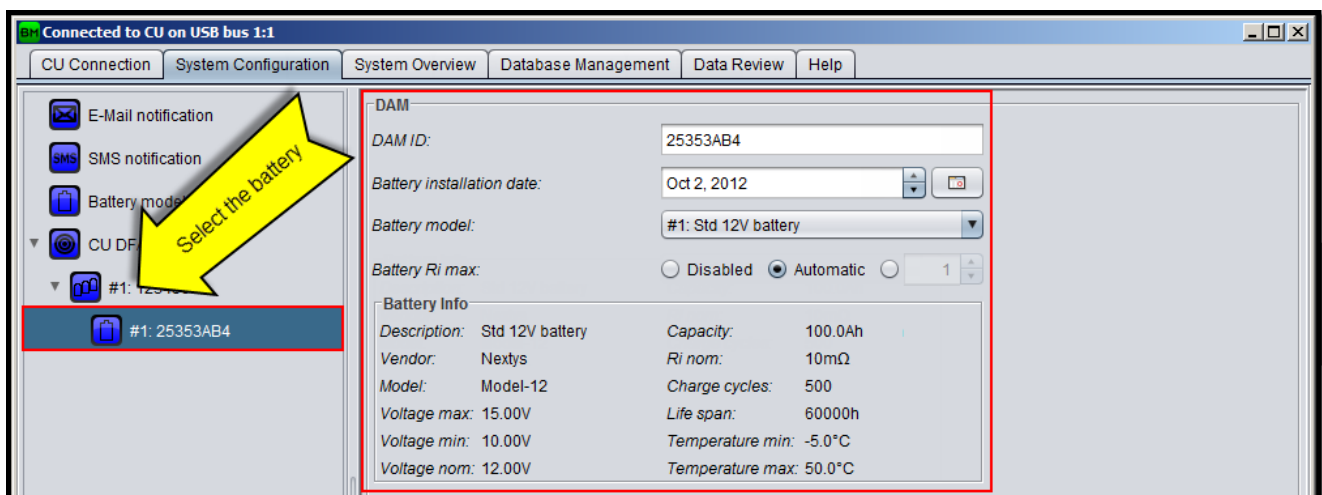


Figure 37: Battery configuration

7.4.3 Automatic string add-on

1. If not done yet, click on “**Start discover**” button as shown in Figure 38 to put the CU in *Discovery* mode. In this mode the CU checks for new IDAMs or DAMs present in the system.



Figure 38: Start discover

2. Check the IDAM to be associated with the string is powered OFF and then power it ON
3. A new string should appear on the tree, if not return to point 2.
4. Select the added string icon as shown in Figure 35 and fill in the fields as explained in §7.4.1.

7.4.4 Automatic battery add-on

1. If not done yet, click on “**Start discover**” button as shown in Figure 38 to put the CU in discovery mode. In this mode the CU checks for new IDAMs or DAMs present in the system.
2. Select the string where the battery has to be added.
3. Check the DAM to be added is powered OFF and then power it ON (connect to the battery)
4. A new battery should appear on the tree, if not - return to point 3.
5. Select the added battery icon as shown in Figure 37 and fill in the fields as explained in §7.4.2.

7.5 Configuration management

Configuration management is done using the buttons on the bottom of the “**System Configuration**” tab as shown on Figure 39 and explained below.

- ▶ **Read from CU:** Click to read the configuration from the connected CU. This button is enabled only if a CU is connected.
- ▶ **Write to CU:** Click to write and activate the configuration to the connected CU. This button is enabled only if a CU is connected.
- ▶ **Read from file:** Click to read the configuration from a file (xml type).

- ▶ **Write to file:** Click to save the current configuration to file (xml type).



Figure 39: Configuration management buttons

8 BATTMASTER® software

There are 6 different activities that can be performed, each one related to a tab, as explained below.

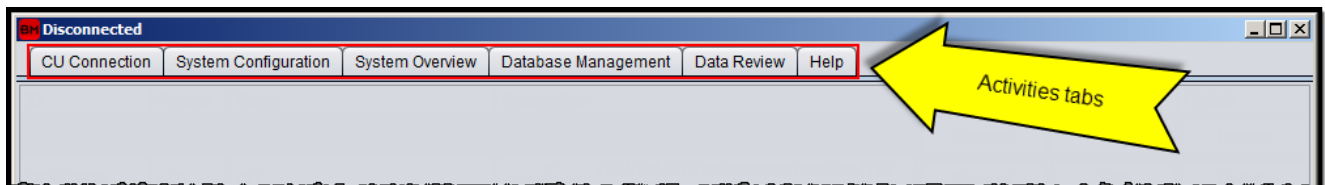


Figure 40: Application tabs






8.1 CU connection

This tab is used to manage the connection with the CU. Use of this tab is explained on §7.2.

8.2 System configuration

This tab is used to configure the system. Use of this tab is explained on §7.3.

8.3 System overview

	CU: the icon change color depending on the alarm status of the CU, red if an alarm is ongoing or green otherwise.
	String: the icon change color depending on the alarm status of the IDAM. Yellow: alarm signaling is disabled by the user. Red: an alarm is ongoing. Green: no alarm is ongoing.
	Battery: the icon change color depending on the alarm status of the DAM. Yellow: alarm signaling is disabled by the user. Red: an alarm is ongoing. Green: no alarm is ongoing.
	RTL: informs the user that the device is performing Real Time Logging.
	Automatic RTL: informs the user that the device is performing automatic Real Time Logging.



	<p>Signal strength: it represents the RF signal strength. The icon represents the signal strength with the number of visible bars. 5 bars represent the stronger signal and 1 bar the weakest.</p>
	<p>Signal absence: shown when the RF communication with the device is broken.</p>

Table 3: Icons

This system overview tab shows the current system status. The different devices composing the system are represented on the left tree where the user can select a device to view its actual status. For each device, the user can choose between “**Status**” and “**Log**” view.

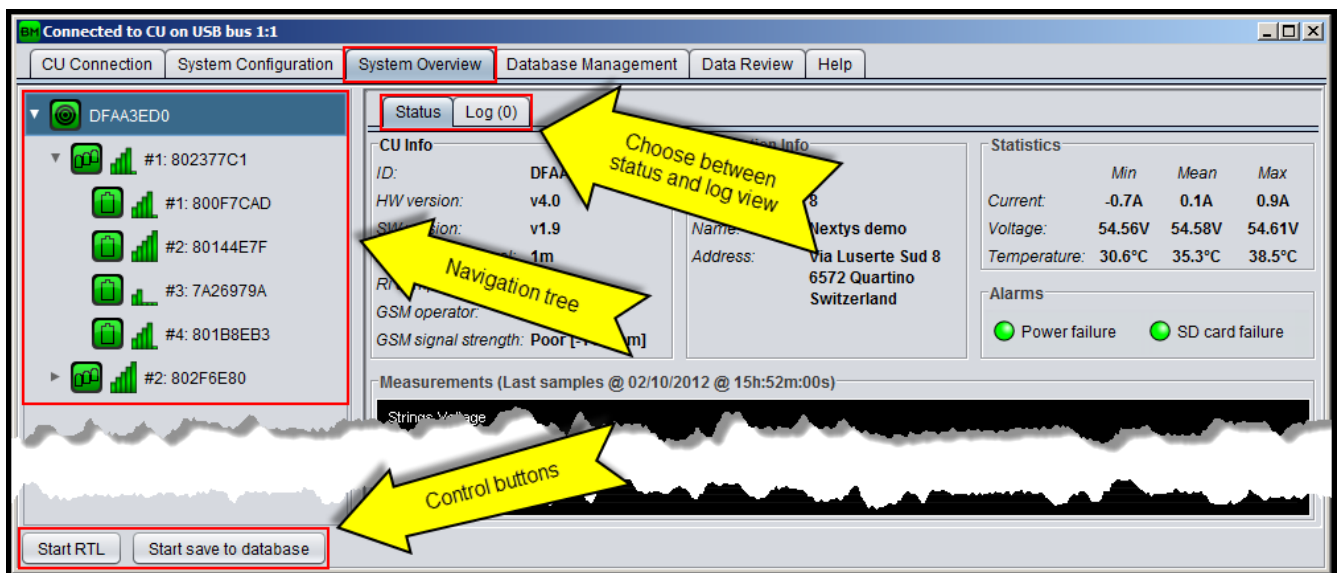


Figure 41: System overview tab

- ▶ **Status view:** Depends on the device type selected and is explained in more detail below.
- ▶ **Log view:** Shows the events and alarms history (see §9 for events and alarm description) for each device level (system, string, battery) since the application connection to the CU as shown on Figure 42.

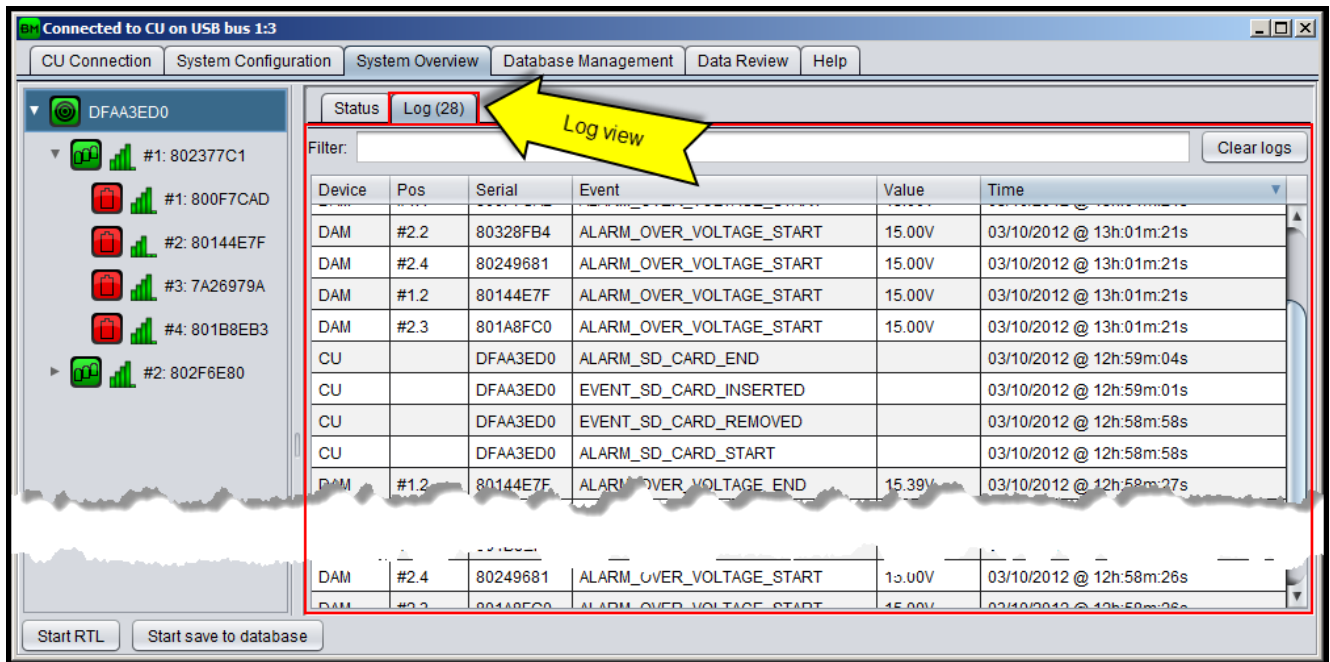


Figure 42: System overview log tab

Click on **“Start RTL”** (*Real Time Logging*) button to log strings and batteries measurements in real time. During RTL the CU will continue to save measurements on the SD card using the defined acquisition interval. At any moment the user can stop RTL clicking on the button again.

Click on **“Start save to database”** button to start saving the logged measurements to the local database (see §5.7). Click on the button again to stop saving to database.

8.3.1 CU overview

Select the CU icon on the navigation tree to show its actual status.

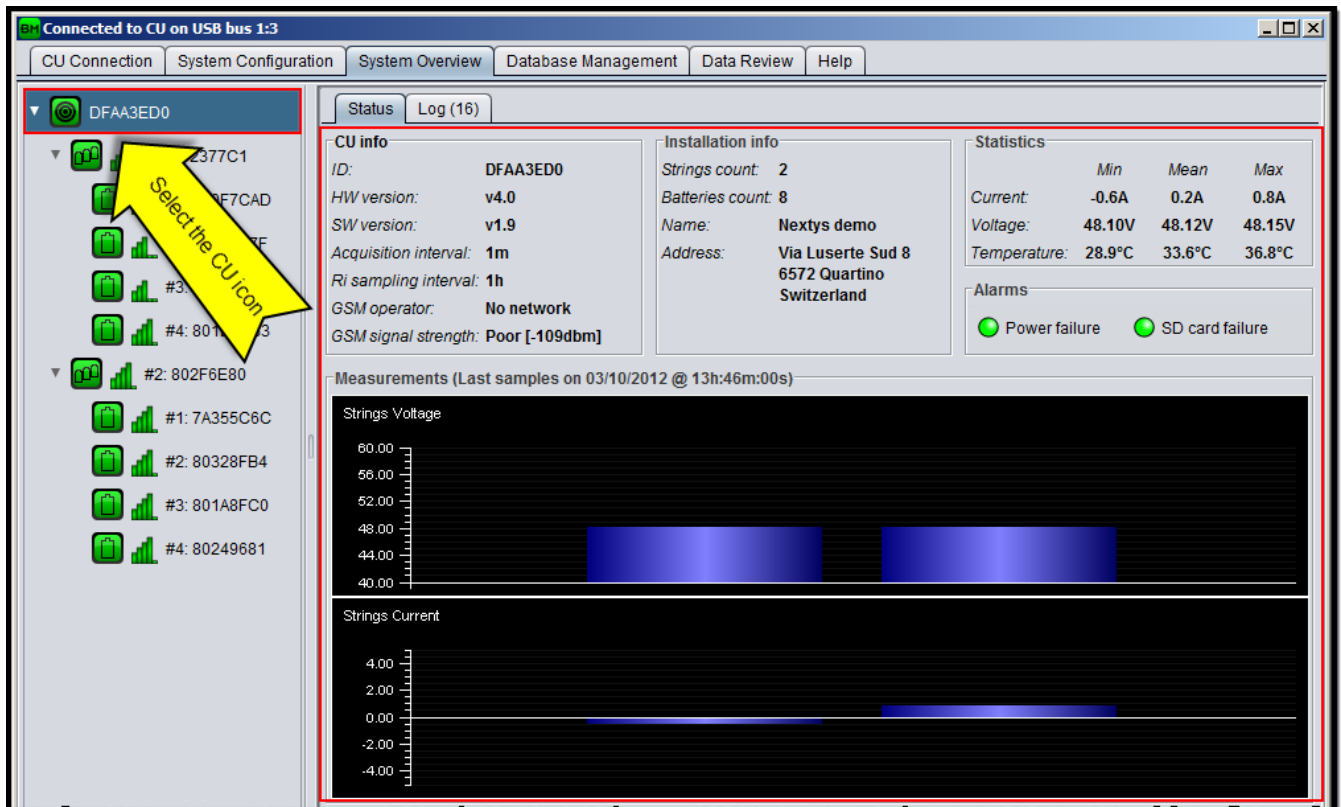


Figure 43: CU overview

The following information is available on the screen:

- ▶ **CU info:** Information about the connected CU (e.g. versions and set values)
- ▶ **Installation info:** Information about the installation (e.g. name and address)
- ▶ **Statistics:** Minimum, mean and maximum values for string currents, voltages and all system batteries temperatures are shown here.
- ▶ **Alarms:** If the corresponding alarm is active the circle becomes red, otherwise it is green.
- ▶ **Measurements:** Graphical representation of the strings current and voltage.

8.3.2 String overview

Select the string icon on the navigation tree to show its actual status.

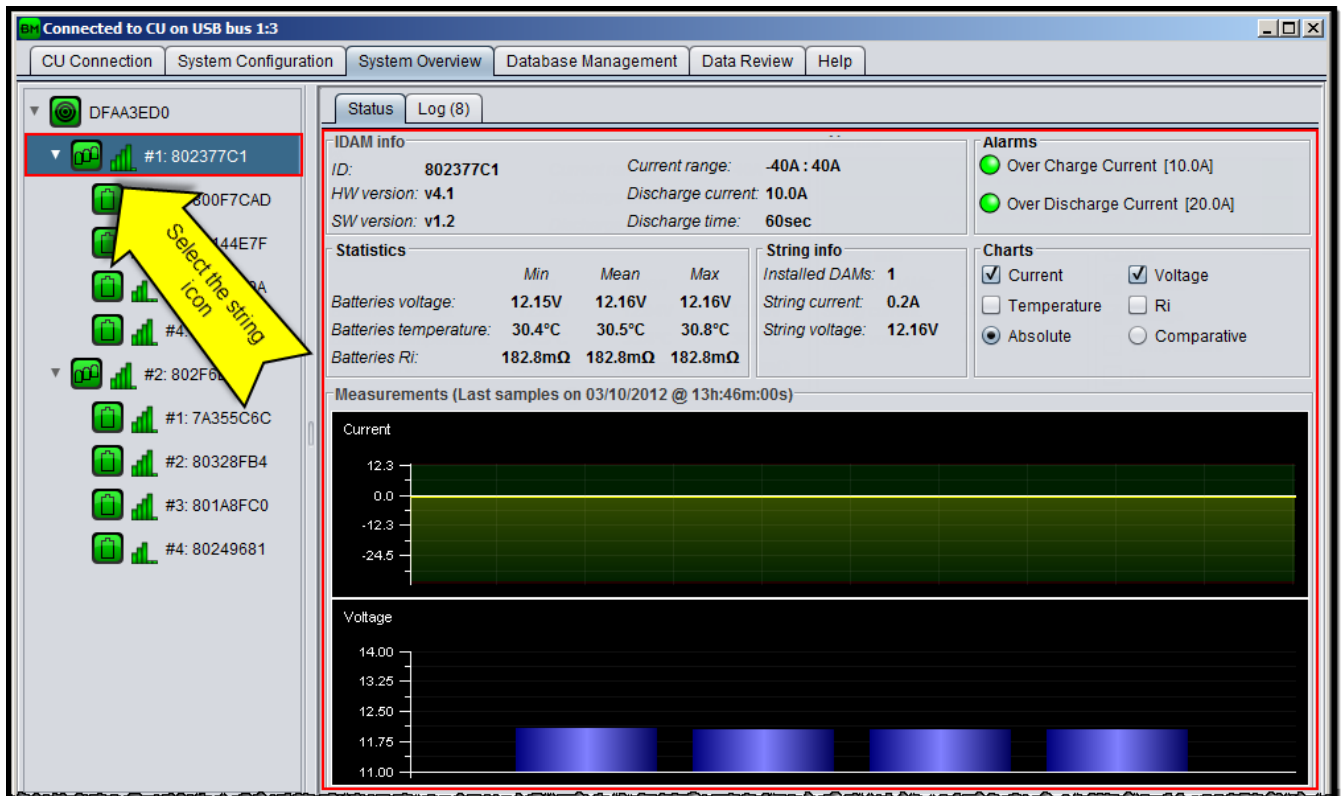


Figure 44: String overview

The following information is available on the screen:

- ▶ **IDAM info:** Information about the IDAM associated to the selected string is shown here.
- ▶ **Alarms:** If the corresponding alarm is active the circle becomes red, otherwise it is green.
- ▶ **Statistics:** Minimum, mean and maximum values for batteries voltage, temperature and internal resistance.
- ▶ **String info:** Information about the parent string.
- ▶ **Charts:** Select the charts shown on the measurements panel.
- ▶ **Measurements:** Graphical representation of the measurements selected in the charts panel.

8.3.3 IDAM replacement

Use the following procedure to replace an IDAM:

1. Right click on the string icon to activate the context menu as shown on Figure 45.

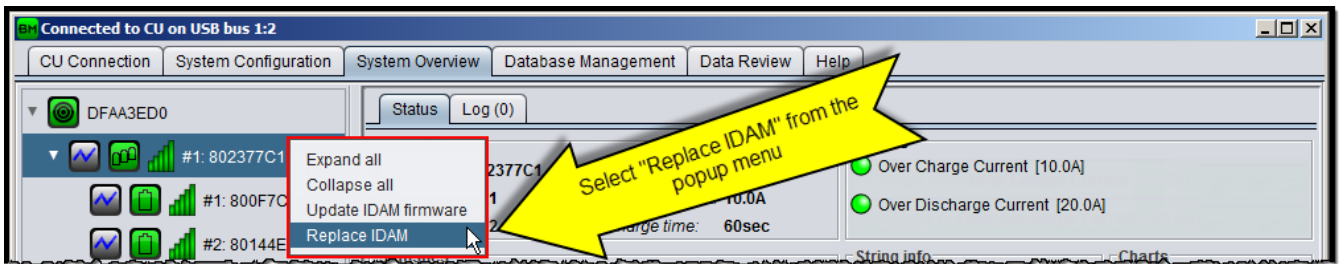


Figure 45: Replace IDAM

2. On the opened dialog insert the ID of the new IDAM either automatically (activating the discover option) or manually and click “OK” (see Figure 51) to confirm.

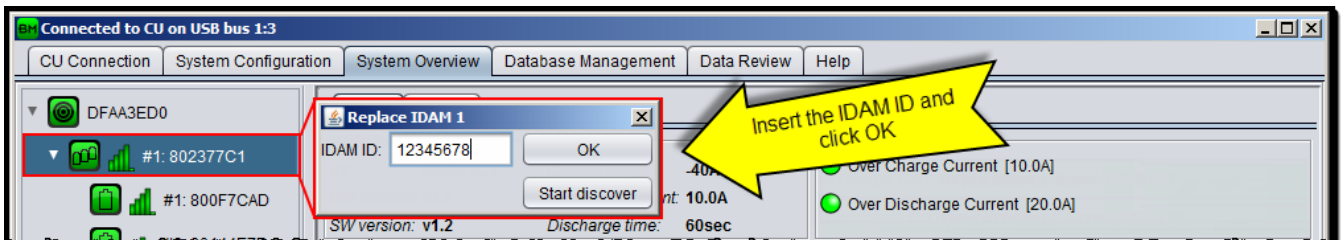


Figure 46: Replace IDAM dialog

8.3.4 Battery overview

Select the battery icon on the navigation tree to show its current status.

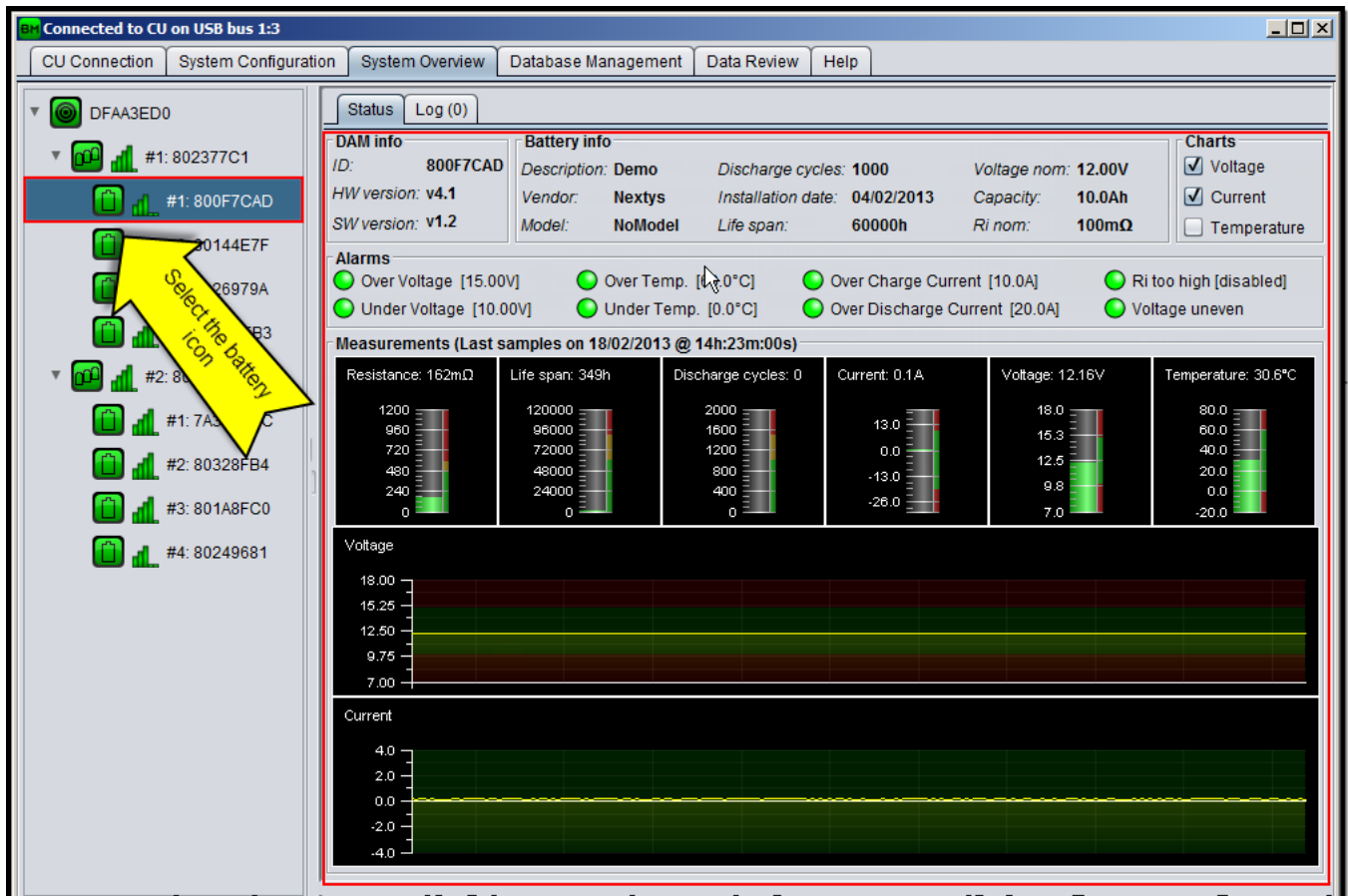


Figure 47: Battery overview

The following information is available on the screen:

- ▶ **DAM info:** Information about the DAM associated to the selected battery.
- ▶ **Battery info:** Generic information and alarm thresholds of the battery.
- ▶ **Alarms:** If an alarm is active the circle becomes red, otherwise it is green.
- ▶ **Charts:** Select the charts shown on the measurements panel.
- ▶ **Measurements:** Graphical representation of the measurements performed on the battery.

8.3.5 DAM replacement

Use the following procedure to replace a DAM:

1. Right click on the battery icon to activate the context as shown on Figure 48Figure 45.

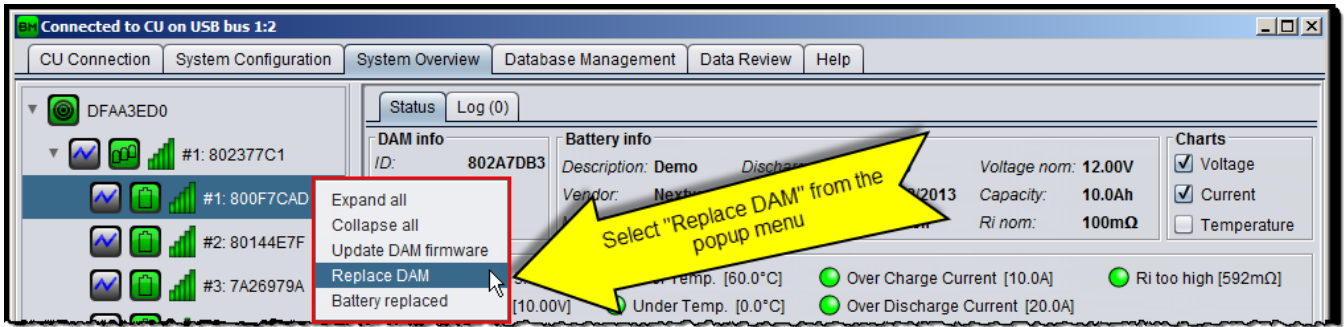


Figure 48: Replace IDAM

2. On the opened dialog insert the ID of the new IDAM either automatically (activating the discover option) or manually and click “OK” (see Figure 51) to confirm.

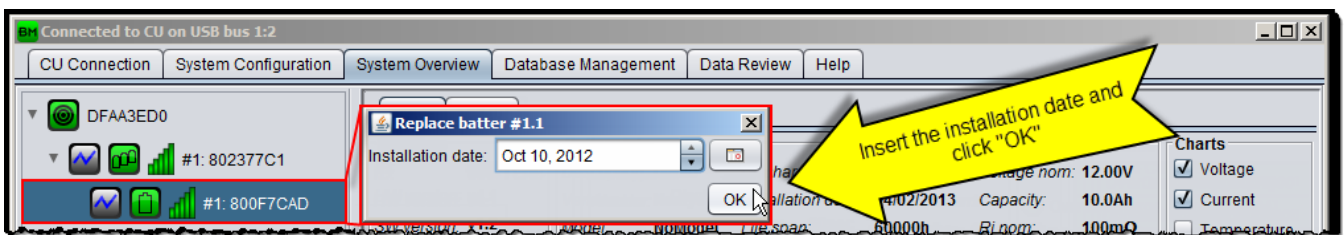


Figure 49: Replace DAM dialog

8.3.6 Battery replacement

Use the following procedure to replace a battery:

1. Right click on the battery icon as shown on Figure 50.

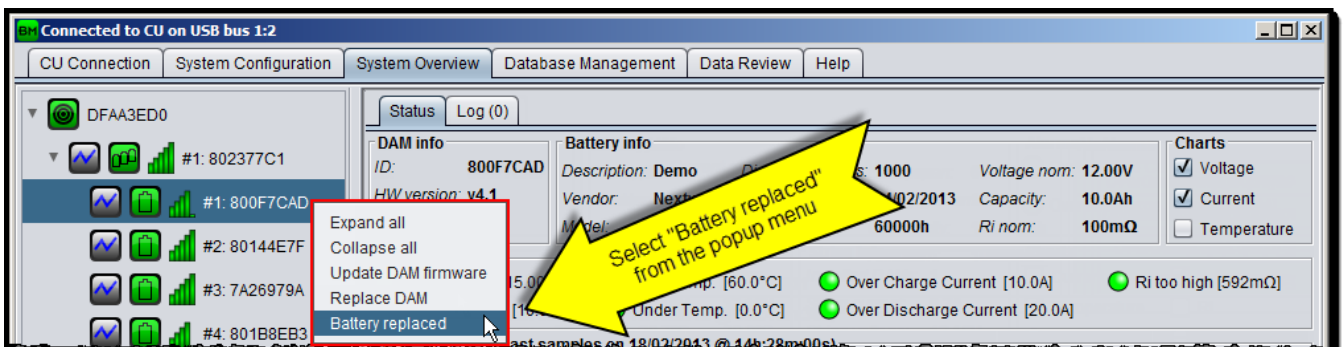


Figure 50: Replace battery

2. On the opened dialog insert the installation date (the current date is entered by default) and click “OK” (see Figure 51) to inform the system that a new battery has been installed.

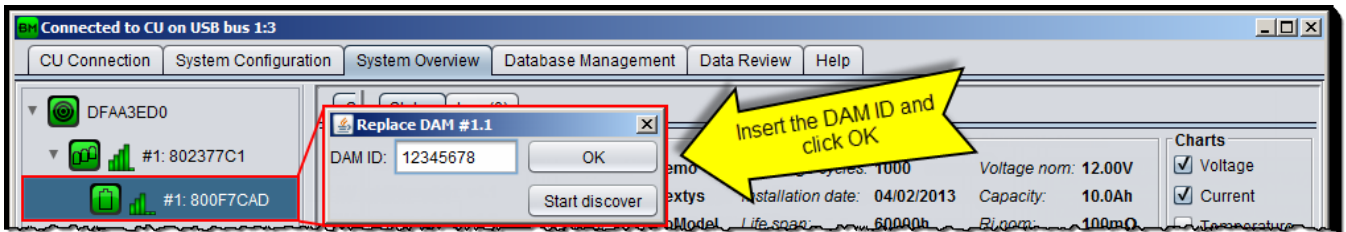


Figure 51: Battery installation date

8.3.7 Enable/Disable alarm signaling

When a string or battery enters fault condition (e.g. Battery overvoltage voltage) the CU signals the error with the Red led, the digital output and the buzzer. In case the fix cannot be immediate, it is possible to disable the alarm signaling on the specific device using the context menu, this to ease detection of other faults.

The following procedure is used for a string:

1. Right click on the string icon to activate the context menu as shown the image below.

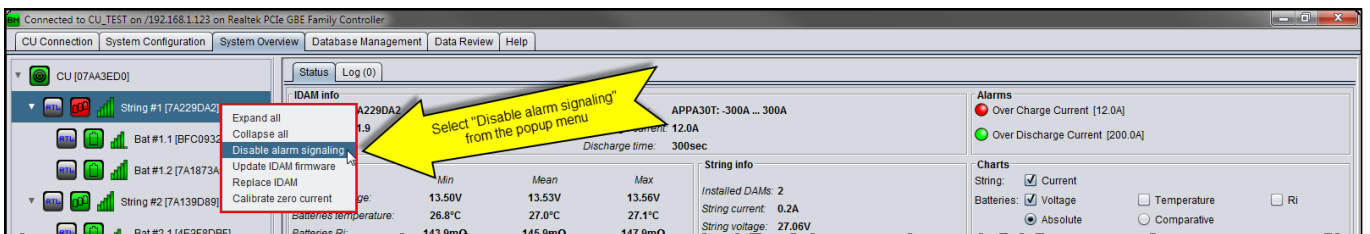


Figure 52: Disable alarm signaling

2. The icon turns yellow indicating that the alarm signaling is disabled.

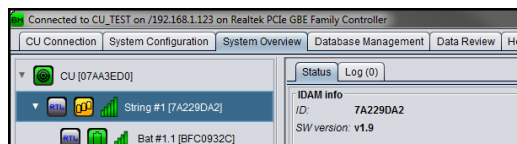


Figure 53: Alarm signaling disable

3. Once the fault is fixed restore the alarm signaling using the context menu as show below.

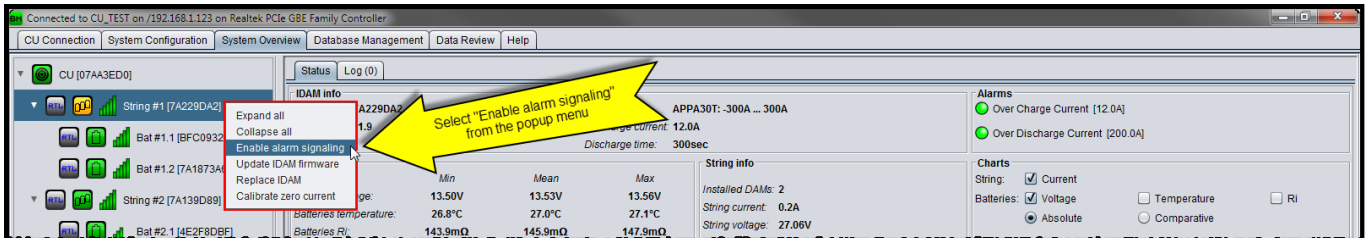
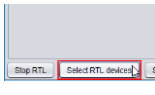
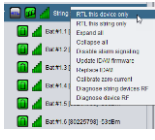
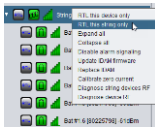
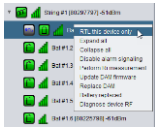


Figure 54: Enable alarm signaling

For batteries the same procedure, with its context menu, is used.

8.3.8 Selective RTL

RTL can be activated for a specific number of devices only in the following manner:

	<p>With the “Select RTL device” button it is possible to select the RTL devices individually through dialog window.</p>
	<p>With the string popup menu item “RTL this device only”, RTL is activated on the string IDAM only.</p>
	<p>With the string popup menu item “RTL this string only”, RTL is activated on the devices of the string only.</p>
	<p>With the battery popup menu item “RTL this device only”, RTL is activated on the battery DAM only.</p>

8.3.9 Adjust Ri alarm thresholds

After installing the system, user may want to fine tune the Ri alarms thresholds for each battery. This is possible using the “Adjust Ri alarm thresholds” button (see image below). On the appearing dialog user can enter the value for each installed DAM individually or the whole string at once using the left buttons.

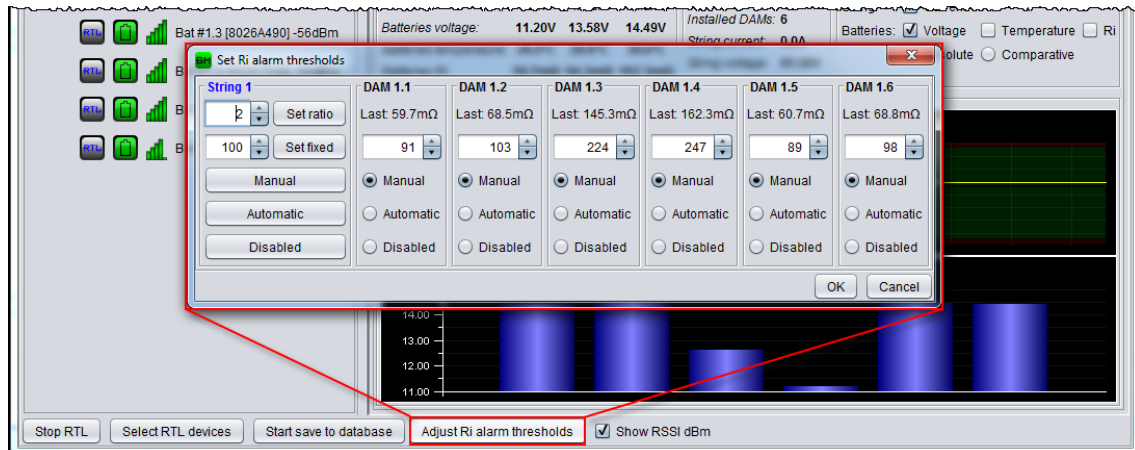


Figure 55: Adjust Ri alarm thresholds dialog

8.3.10 Diagnose radio link quality

Radio signal may be disturbed by environmental obstacles or noise. After installation of the system is possible to diagnose the link quality to spot weak or disturbed radio signal. This is possible using the “Diagnose RF” button.

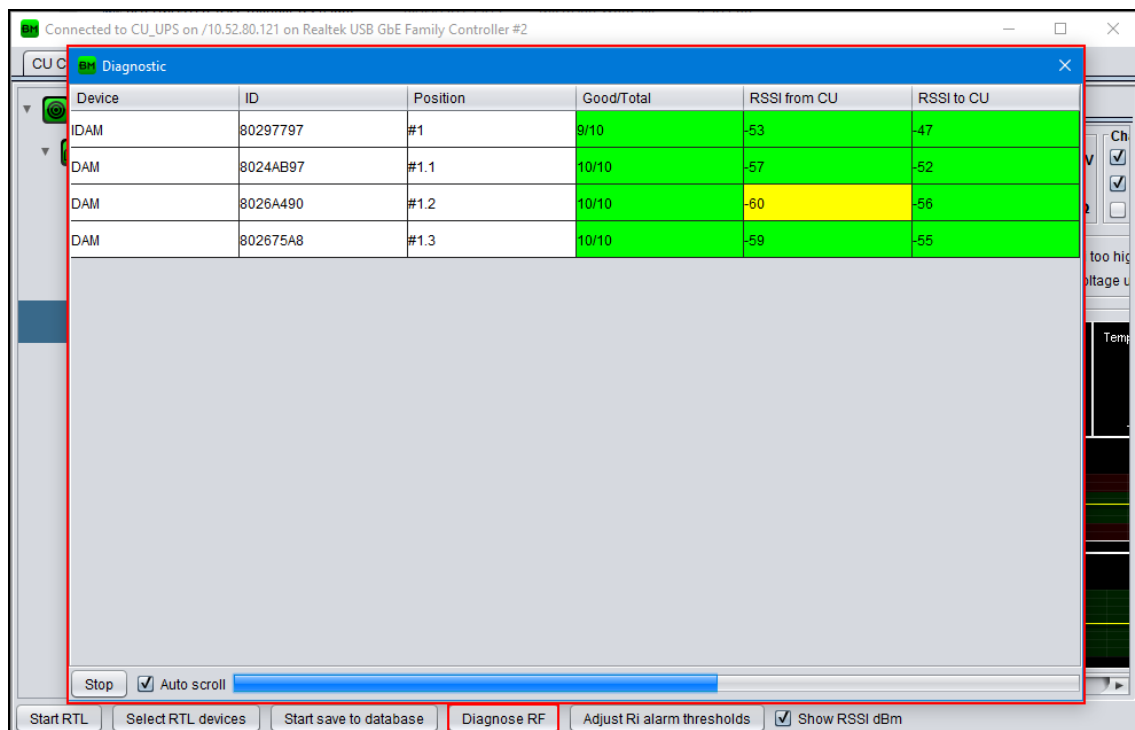



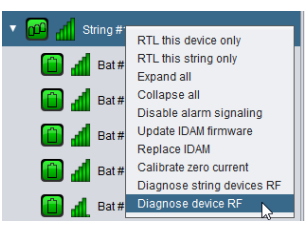

Figure 56: Diagnose RF dialog

On the appearing window the result for each device is displayed. It is possible to stop the test at any moment closing the window or pressing the “Stop” button on top of the page. The results can be save to a

file once the test is finished or interrupted. Depending on the measured value the column “Goog/Total”, “RSSI from CU and “RSSI to CU” have different background colour.

GREEN	Prefect: The link is in perfect conditions. No problem communicating with the device.
YELLOW	Good: The link is in perfect conditions. No problem communicating with the device.
ORANGE	Poor: The link is in poor conditions. Communication work, but packet may be dropped causing slow down.
RED	Bad: The link is bad. Action must be performed to increase the link quality.

It is possible to perform the test repeatedly on a selected number of devices through the following menu items.

	<p>From the string popup menu, select “Diagnose string devices RF” to test continuously all the devices of contained on the string.</p>
	<p>From the string popup # menu, select “Diagnose device RF” to test continuously the string IDAM.</p>
	<p>From the battery popup menu, select “Diagnose device RF” to test continuously the string battery DAM.</p>

8.4 Database management

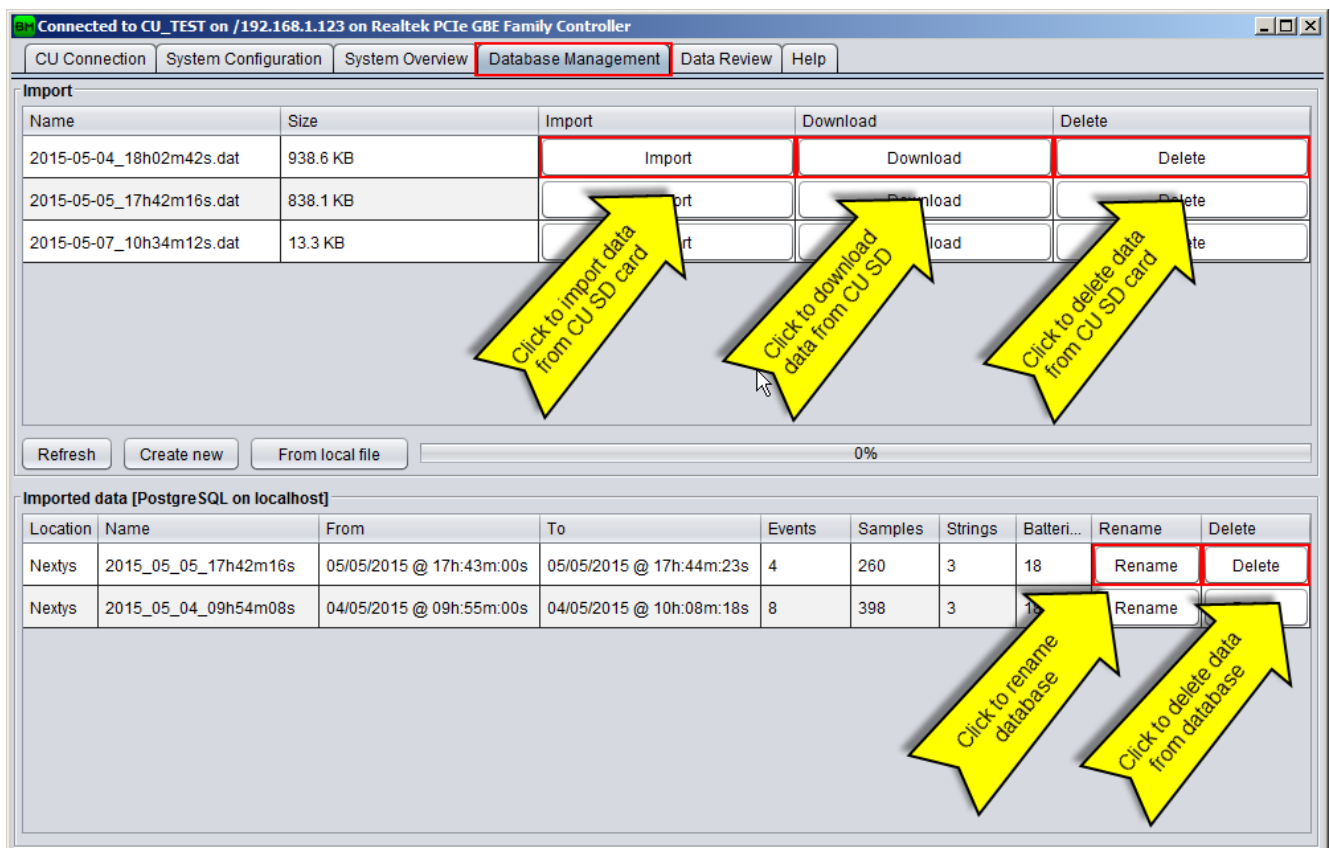
The data files stored on the connected CU SD card are visible on the top area of the tab. The following buttons are available:

- ▶ **Import:** Click to import the data file stored on the CU SD card to the PC database.
- ▶ **Download:** Click to download the data file stored on the CU SD card to the PC.

- ▶ **Delete:** Click to delete the data file from the CU SD card.
- ▶ **Refresh:** Click to refresh the list of data files stored on the CU SD card.
- ▶ **Create new:** Click to create a new data file used by the CU to save the data.
- ▶ **From local file:** Click to import from a local data file to the local database.

On the bottom area of the tab the imported data is shown. The following buttons are available:

- ▶ **Rename:** Rename the database.
- ▶ **Delete:** Click to delete the data form the database.



The screenshot shows the 'Database Management' tab in a software application. The interface is divided into two main sections. The top section, titled 'Import', contains a table with three rows of data files. Each row has columns for 'Name', 'Size', 'Import', 'Download', and 'Delete'. Below this table are buttons for 'Refresh', 'Create new', and 'From local file', along with a progress indicator at 0%. The bottom section, titled 'Imported data [PostgreSQL on localhost]', contains a table with two rows of imported data. Each row has columns for 'Location', 'Name', 'From', 'To', 'Events', 'Samples', 'Strings', 'Batteri...', 'Rename', and 'Delete'. Yellow arrows with text labels point to specific buttons in both tables: 'Click to import data from CU SD card' points to the 'Import' button in the first row of the top table; 'Click to download data from CU SD' points to the 'Download' button in the second row; 'Click to delete data from CU SD card' points to the 'Delete' button in the third row; 'Click to rename database' points to the 'Rename' button in the first row of the bottom table; and 'Click to delete data from database' points to the 'Delete' button in the second row.

Figure 57: Database management tab

8.5 Data review

Imported data can be reviewed for further analysis by using the “**Data review**” tab. First select the data to review by clicking on the “**Open data**” button as shown on Figure 58.

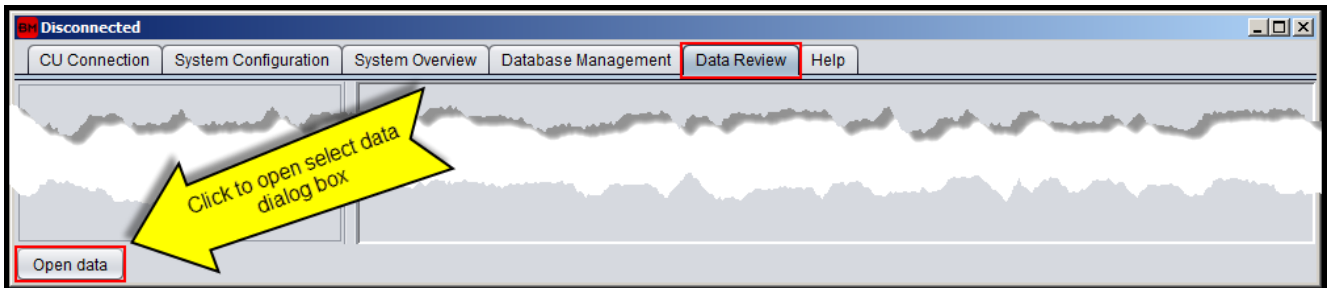


Figure 58: Data review tab

From the “**Select data**” dialog select the data clicking on the “**Open**” button as shown on Figure 59.

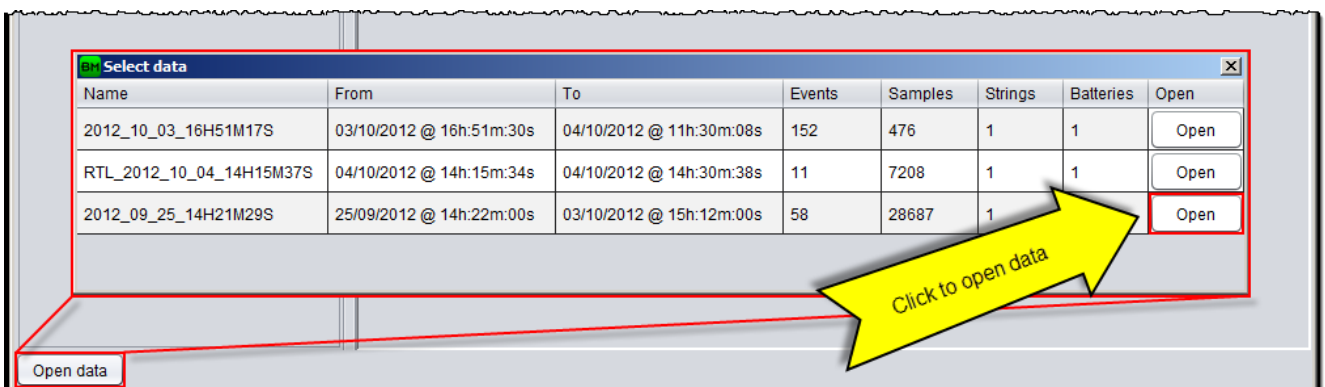


Figure 59: Select the data to be reviewed

8.5.1 CU review

Select the *CU* icon to open the panels shown on Figure 60.

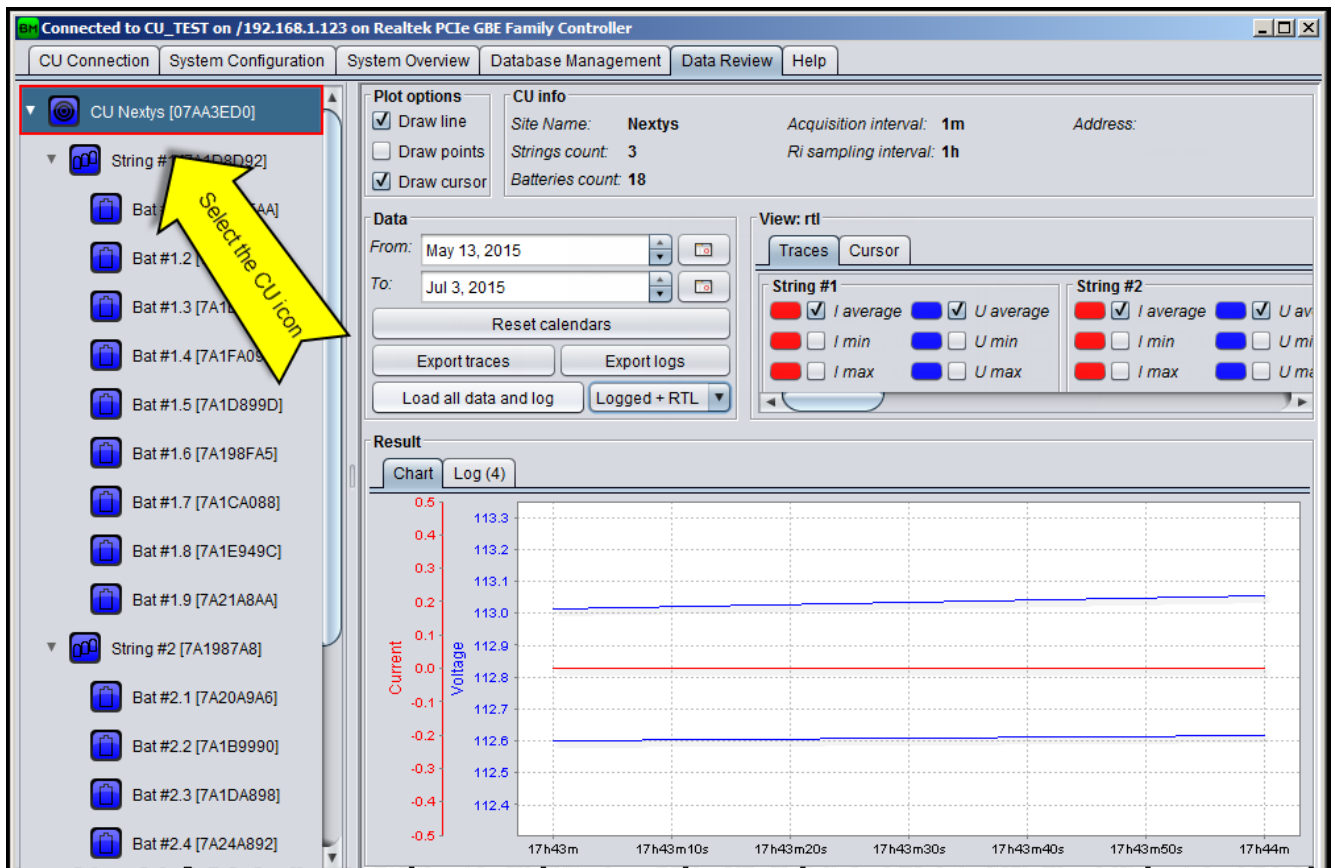


Figure 60: CU review

- ▶ **Plot options:** Check the desired option to customize the way the chart is drawn.
- ▶ **CU info:** Shows information about the CU configuration.
- ▶ **Data:** Click on the “**Load**” button to load data for the selected time interval. Select the RTL checkbox to load the RTL samples.
- ▶ **View:** On the “**Traces**” tab check/uncheck to show/hide the data shown on the result chart. Click on the colored spot to select the trace color. The measured values at the cursor position are shown on the “**Cursor**” tab. Cursor is positioned by clicking on the chart area (see §8.5.5).
- ▶ **Result:** The loaded data and logs are shown. Select the “**Chart**” tab to view the measured values in a chart. Select “**Log**” tab to view the list of alarms / events occurred during the selected interval of time.

8.5.2 String review

Select the *string icon* to open the panels shown on Figure 61.

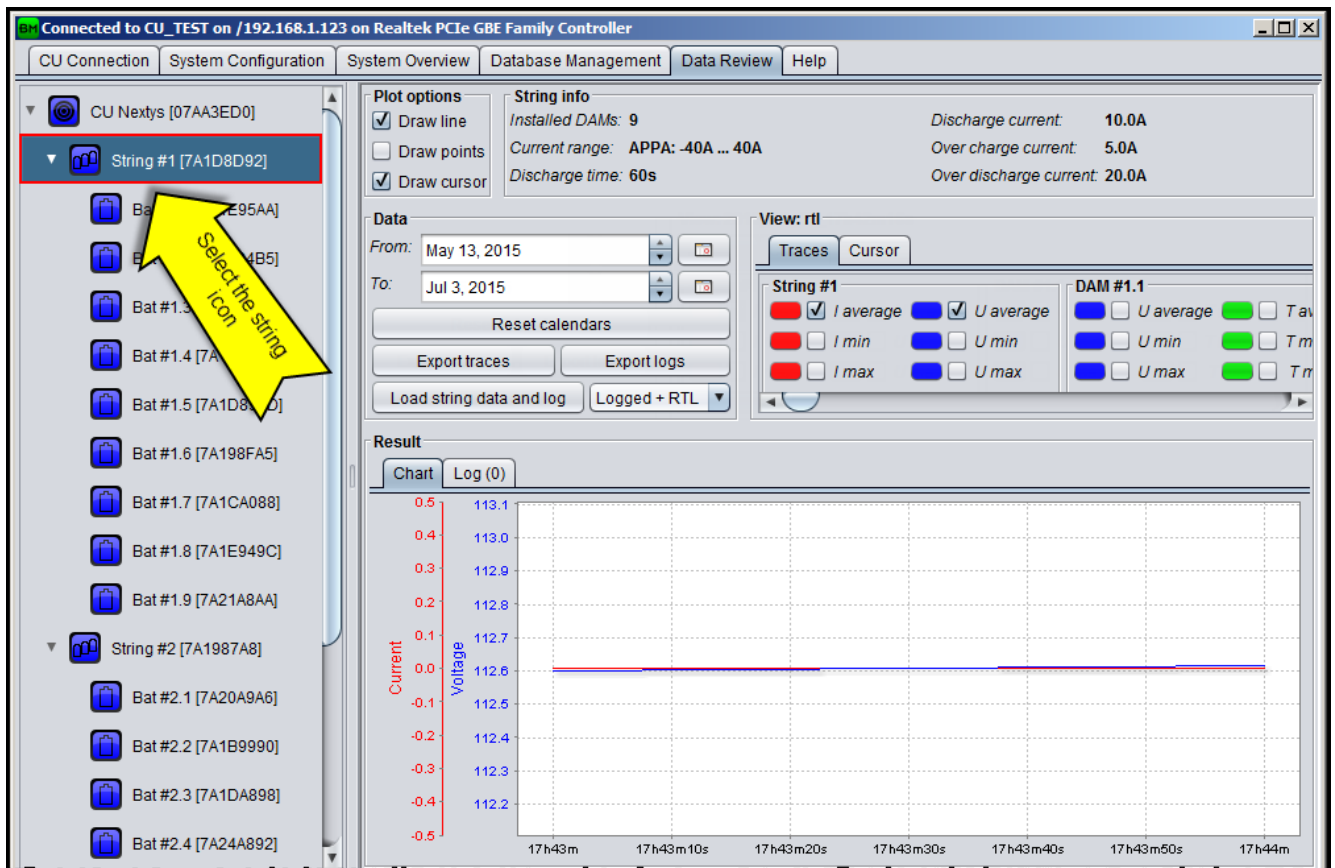


Figure 61: String review

- ▶ **Plot options:** Check the desired option to customize the way the chart is drawn.
- ▶ **String info:** Shows information about the string configuration.
- ▶ **Data:** Click on the “Load” button to load data for the string and related batteries for the selected time interval. Select the RTL checkbox to load the RTL samples.
- ▶ **View:** Check/uncheck the “Traces” tab to show/hide the data shown on the result chart. Click on the colored spot to select the trace color. The measured values at the cursor position are shown on the “Cursor” tab. Cursor is positioned by clicking on the chart area (see §8.5.5).
- ▶ **Result:** The loaded data and logs are shown. Select the “Chart” tab to view the measured values in a chart. Select “Log” tab to view the list of alarms / events occurred during the selected interval of time.

8.5.3 Battery review

Select the *battery* icon to open the panels shown on Figure 62.

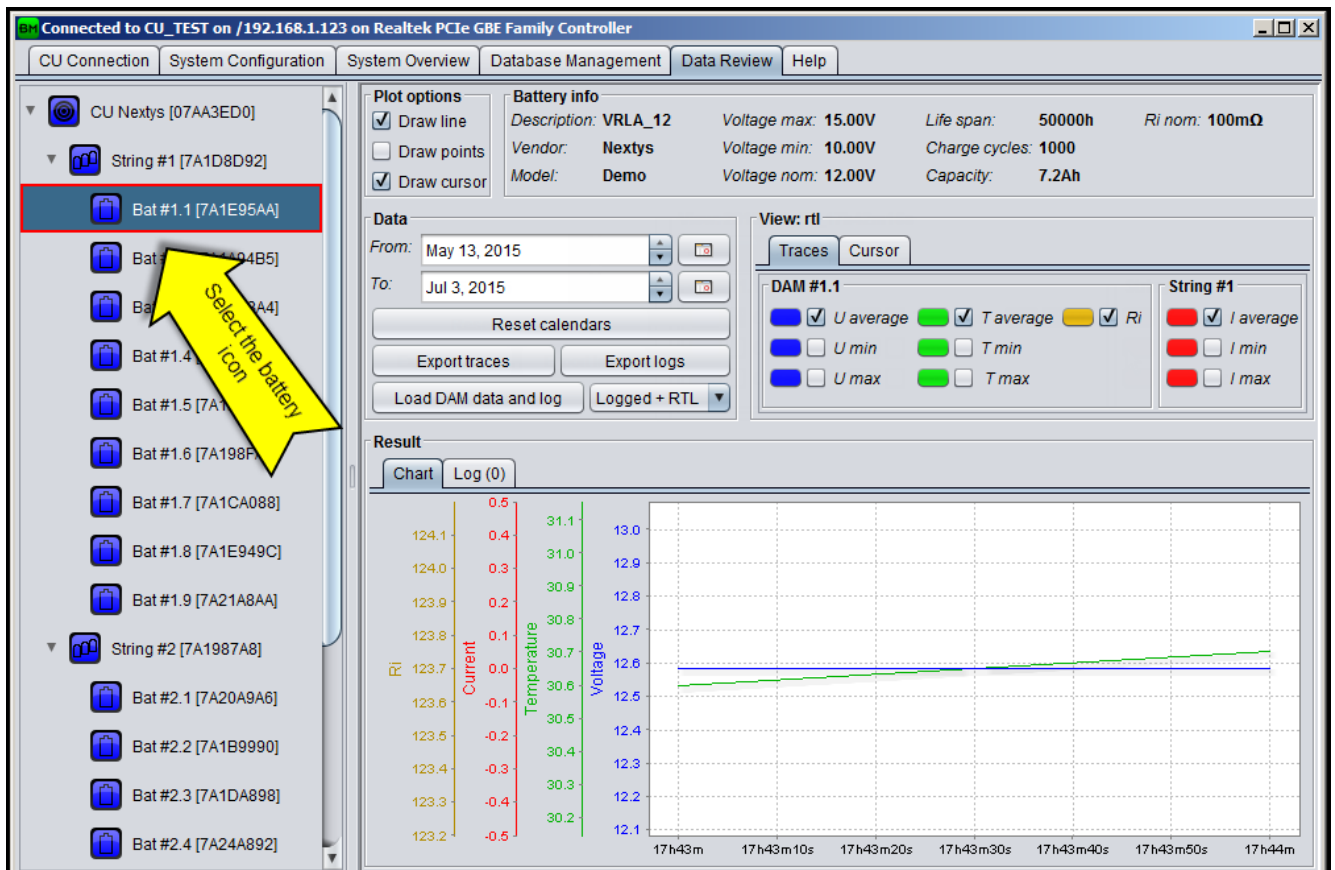


Figure 62: Battery review

- ▶ **Plot options:** Check the desired option to customize the way the chart is drawn.
- ▶ **Battery info:** Shows information about the battery configuration.
- ▶ **Data:** Click on the “**Load**” button to load the battery data for the selected interval of time. Click “**Export DAM measures to CSV**” to export the DAM measured values for the selected interval of time to a CSV file.
- ▶ **View:** Check/uncheck the “**Traces**” tab to show/hide the data shown on the result chart. Click on the colored spot to select the trace color. The measured values at the cursor position are shown on the “**Cursor**” tab. Cursor is positioned clicking on the chart area (see §8.5.5).
- ▶ **Result:** Shows the loaded data and logs. Select the “**Chart**” tab to view the measured values in a chart. Select “**Log**” tab to view the list of alarms / events occurred during the loaded interval of time.

8.5.4 Multiple traces view

The traces of various batteries in a string can be compared. This can be done by selecting the desired ones from a popup menu available by right clicking on the trace check box.

For example, to select the “**U average**” for all the batteries in a string, use the following procedure:

1. Right click on the “*U average*” check box on any battery of the string as shown on Figure 63.

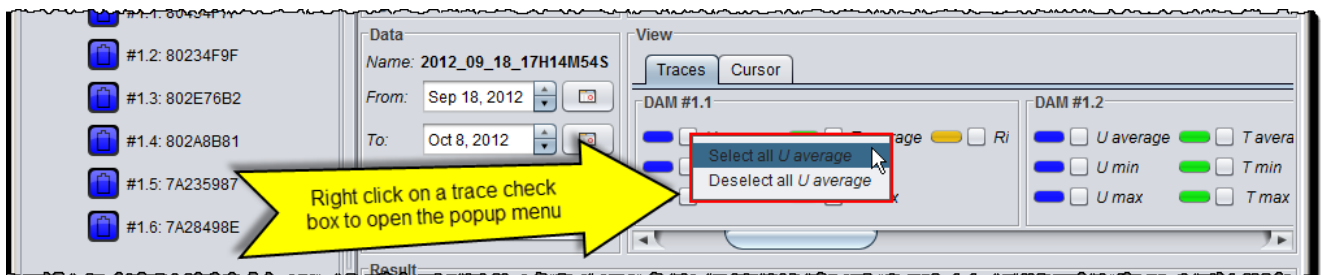


Figure 63: Multiple traces selection

2. On the popup menu click on “*Select all U average*” to select all the “*U average*” traces in the string.

8.5.5 Cursor

Click on the chart area as shown on Figure 64 to position a cursor. The values at the cursor position are shown on the “**Cursor**” tab.

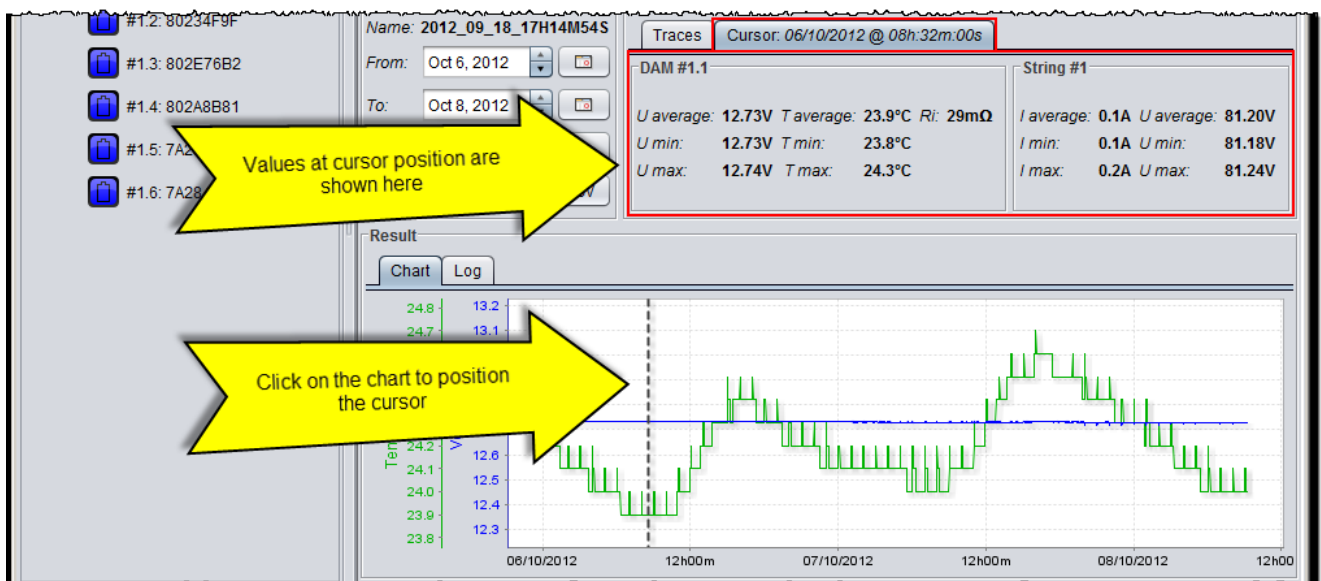


Figure 64: Cursor

8.5.6 Change trace color

Click on the color spot beside the trace you want to modify. On the “Pick up a color” dialog select the new color and click “OK” to confirm (see Figure 65).

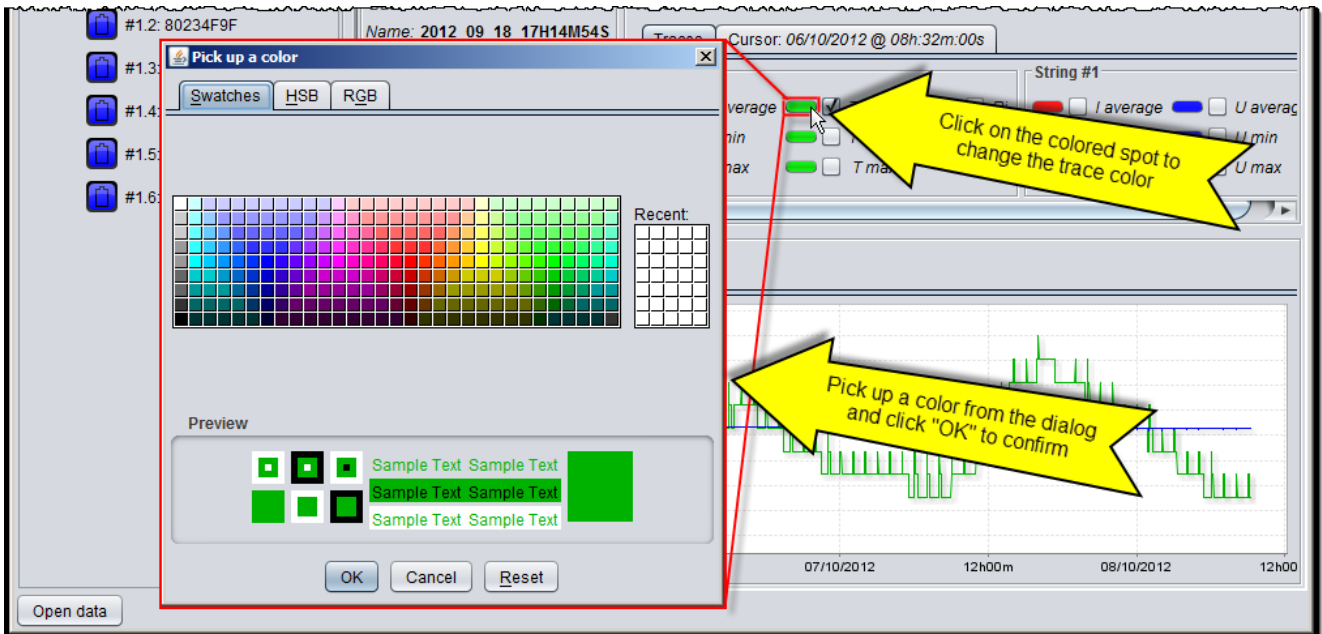


Figure 65: Change trace color

8.5.7 Chart zoom

To zoom a specific area on a chart draw a rectangle starting from the top left corner of the area to be zoomed by keeping the left mouse button pressed as shown on Figure 66.

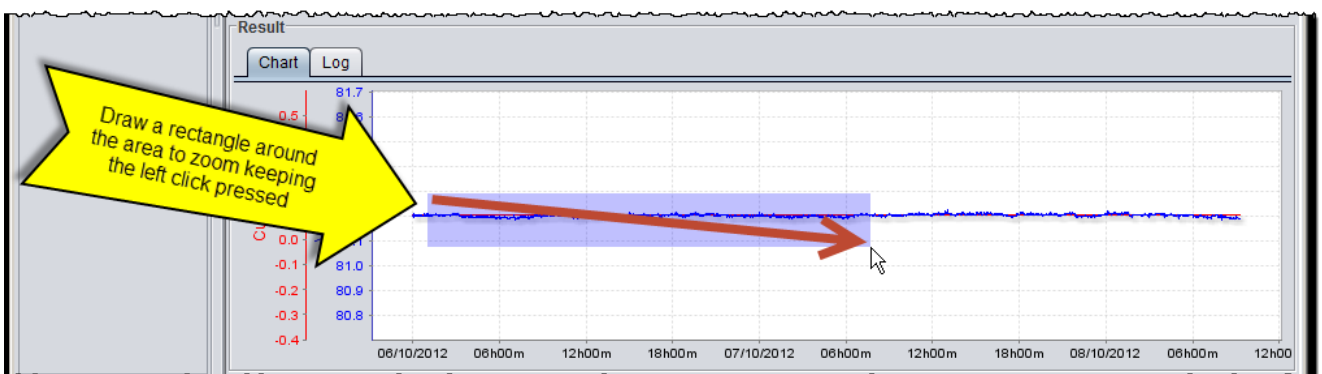


Figure 66: Zoom area

To zoom out move the mouse from right to left keeping the left mouse button pressed.

8.6 Help

On the help tab the user can find the software version and configure the application as follows:

- ▶ **Open user manual:** Opens the user manual PDF file on the PC.
- ▶ **Software version:** Version of the **BATTMASTER®** software.
- ▶ **CU bundled firmware version:** Bundle version used for CU firmware update.
- ▶ **IDAM bundled firmware version:** Bundled version used for IDAM firmware update.
- ▶ **DAM bundled firmware version:** Bundled version used for DAM firmware update
- ▶ **Check for software updates at startup:** If the box is checked the application contacts the **NEXTYS** update website at startup, if a new software release is available a choice is given to the user to update the software (see §5.14.2).
- ▶ **Start background update:** Used to start the background update procedure as explained on §5.14.3.
- ▶ **Update devices automatically:** If checked, the application automatically updates the IDAM and DAM firmware if a new release if available within the installed application.
- ▶ **Temperature unit:** Selects between Celsius and Fahrenheit unit.

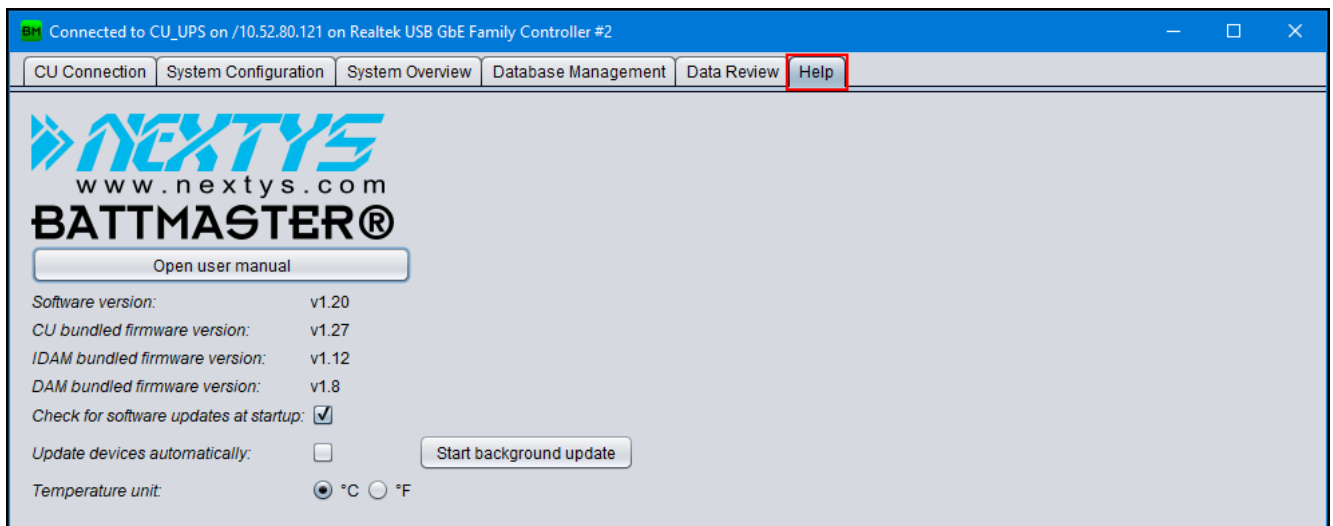


Figure 67: Help tab

9 Events and alarms

ID [Hex]	Name	Value
0x0001	ALARM_BUFFER_FULL	None.
Description		
The DAM or IDAM was unable to send an alarm or event because the buffer was full. This should only happen if the RF link with the CU is broken for a long period of time.		

ID [Hex]	Name	Value
0x0002	ALARM_UNDER_VOLTAGE_START	Threshold voltage triggering the alarm (U min).
Description		
The DAM measured voltage drops below the “U min” set.		

ID [Hex]	Name	Value
0x0003	ALARM_UNDER_VOLTAGE_END	The minimum voltage reached during the alarm.
Description		
The DAM measured voltage returns above the “U min” set.		

ID [Hex]	Name	Value
0x0004	ALARM_OVER_VOLTAGE_START	Threshold voltage triggering the alarm (U max).
Description		
The DAM measured voltage exceed the “U max” set.		

ID [Hex]	Name	Value
0x0005	ALARM_OVER_VOLTAGE_END	The maximum voltage reached during the alarm.
Description		
The DAM measured voltage returns below the “U max” set.		

ID [Hex]	Name	Value
0x0006	ALARM_UNDER_TEMPERATURE_START	Threshold temperature triggering the alarm (T min).
Description		
The DAM measured temperature drops below the “T min” set.		

ID [Hex]	Name	Value
a0x0007	ALARM_UNDER_TEMPERATURE_END	The minimum temperature reached during the alarm.
Description		
The DAM measured temperature returns above the “T min” set.		

ID [Hex]	Name	Value
0x0008	ALARM_OVER_TEMPERATURE_START	Threshold temperature triggering the alarm (T max).
Description		
The DAM measured temperature exceed the “U max” set.		

ID [Hex]	Name	Value
0x0009	ALARM_OVER_TEMPERATURE_END	The maximum temperature reached during the alarm.
Description		
The DAM measured temperature returns below the “T max” set.		

ID [Hex]	Name	Value
0x000A	ALARM_OVER_CHARGE_CURRENT_START	Over charge current alarm threshold set on IDAM.
Description		
The IDAM measured charge current exceeds the threshold.		

ID [Hex]	Name	Value
0x000B	ALARM_OVER_CHARGE_CURRENT_END	The maximum charge current reached during the alarm.
Description		
The DAM measured charge current drops below the alarm threshold.		

ID [Hex]	Name	Value
0x000C	ALARM_OVER_DISCHARGE_CURRENT_START	Over discharge current alarm threshold set on IDAM.
Description		
The IDAM measured discharge current exceeds the threshold.		

ID [Hex]	Name	Value
0x000D	ALARM_OVER_DISCHARGE_CURRENT_END	The maximum discharge current reached during the alarm.
Description		
The DAM measured charge current drops below the alarm threshold.		

ID [Hex]	Name	Value
0x000E	ALARM_POWER_FAILURE_START	None.
Description		
CU is running on internal NiMH batteries, no external power available.		

ID [Hex]	Name	Value
0x000F	ALARM_POWER_FAILURE_END	None.
Description		
CU external power is restored.		

ID [Hex]	Name	Value
0x0010	ALARM_SD_CARD_START	None.
Description		
The CU cannot write data to the SD card. The cause may be the SD is corrupted or not inserted.		

ID [Hex]	Name	Value
0x0011	ALARM_SD_CARD_END	None.
Description		
The CU restores from a SD card failure.		

ID [Hex]	Name	Value
0x0012	ALARM_RI_TOO_HIGH_START	Threshold internal resistance triggering the alarm (Ri max).
Description		
The measured battery internal resistance is exceed the “Ri max” set.		

ID [Hex]	Name	Value
0x0013	ALARM_RI_TOO_HIGH_END	The maximum internal resistance reached during the alarm.
Description		
The measured battery internal resistance returns below the “Ri max” set.		

ID [Hex]	Name	Value
0x0014	ALARM_VOLTAGE_UNEVEN_START	The measured battery voltage when the alarm starts.
Description		
The measured battery voltage is uneven compared to the other batteries in the string.		

ID [Hex]	Name	Value
0x0015	ALARM_VOLTAGE_UNEVEN_END	The measured battery voltage when the alarm ends.
Description		
The measured battery voltage is uneven compared to the other batteries in the string.		

ID [Hex]	Name	Value
0x0016	ALARM_TEMPERATURE_UNEVEN_START	The measured battery temperature when the alarm starts.
Description		
The measured battery temperature is uneven compared to the other batteries in the string.		

ID [Hex]	Name	Value
0x0017	ALARM_TEMPERATURE_UNEVEN_END	The measured battery temperature when the alarm ends.
Description		
The measured battery temperature is uneven compared to the other batteries in the string.		

ID [Hex]	Name	Value
0x0018	ALARM_RI_UNEVEN_START	The measured battery Ri when the alarm starts.
Description		
The measured battery Ri is uneven compared to the other batteries in the string.		

ID [Hex]	Name	Value
0x0019	ALARM_RI_UNEVEN_END	The measured battery Ri when the alarm end.
Description		
The measured battery Ri is uneven compared to the other batteries in the string.		

ID [Hex]	Name	Value
0x0100	EVENT_RF_LINK_DOWN_START	None.
Description		
The CU is unable to communicate with the IDAM or DAM.		

ID [Hex]	Name	Value
0x0101	EVENT_RF_LINK_DOWN_END	None
Description		
Communication with IDAM or DAM restored.		

ID [Hex]	Name	Value
0x0110	EVENT_STRING_DISCHARGE_START	None.
Description		
String discharge cycle detected.		

ID [Hex]	Name	Value
0x0111	EVENT_STRING_DISCHARGE_END	None.
Description		
String discharge cycle finished.		

ID [Hex]	Name	Value
0x0112	EVENT_RI_NOT_MEASURED_START	None.
Description		
Battery status did not allow the Ri measurement for an interval longer then 2 times the Ri acquisition interval (see §5.4).		

ID [Hex]	Name	Value
0x0113	EVENT_RI_NOT_MEASURED_END	None.
Description		
Ri measurement performed after an EVENT_RI_NOT_MEASURED_START event.		

ID [Hex]	Name	Value
0x1000	EVENT_POWER_ON	Power on cycles count.
Description		
Triggered at any device powered on.		

ID [Hex]	Name	Value
0x1001	EVENT_POWER_OFF	None
Description		
CU powered off.		

ID [Hex]	Name	Value
0x1002	EVENT_SD_CARD_REMOVED	None
Description		
The SD card has been removed from the CU.		

ID [Hex]	Name	Value
0x1003	EVENT_SD_CARD_INSERTED	
Description		
The SD card has been inserted into the CU.		

ID [Hex]	Name	Value
0x1004	EVENT_FS_ERROR	
Description		
A file system error on the SD card occurred.		

ID [Hex]	Name	Value
0x1006	EVENT_SD_CARD_FULL_START	
Description		
The SD card is used more than 90% of its capacity.		

ID [Hex]	Name	Value
0x1007	EVENT_SD_CARD_FULL_END	
Description		
The SD card is no more used more than 90% of its capacity.		

ID [Hex]	Name	Value
0x1008	EVENT_STRING_RTL_START	
Description		
An automatic RTL started following a high current measured on the string.		

ID [Hex]	Name	Value
0x1009	EVENT_STRING_RTL_END	
Description		
An automatic RTL has finished.		

ID [Hex]	Name	Value
0x100A	EVENT_BACKGROUND_UPDATE_START	
Description		
Background update started (see §5.14.3).		

ID [Hex]	Name	Value
0x100B	EVENT_BACKGROUND_UPDATE_END	
Description		
Background update finished (see §5.14.3).		

ID [Hex]	Name	Value
0x100C	EVENT_DEVICE_REPLACED	
Description		
IDAM or DAM replaced as shown on §8.3.3 and §8.3.5.		

ID [Hex]	Name	Value
0x100D	EVENT_BATTERY_REPLACED	
Description		
Battery replace as explained on §8.3.6.		

10 Maintenance

10.1 CU batteries replacement

The CU contains an RTC and power backup batteries. These batteries should be replaced every 5 years to ensure correct functioning.

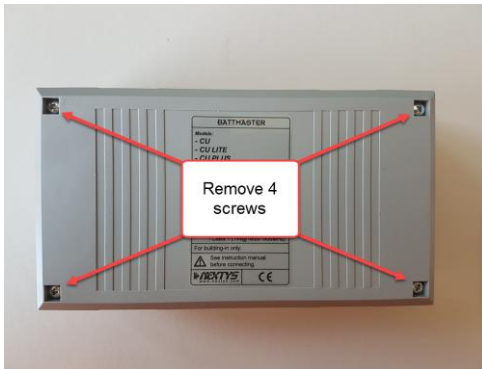


Figure 68: CU back screws

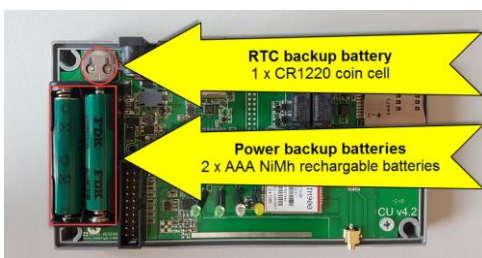


Figure 69: CU batteries

To replace the batteries:

- ▶ Remove the 4 screw on the back as shown on Figure 68.
- ▶ Gently remove the enclosure cover.
- ▶ Batteries are positioned on their older as shown on Figure 69.
- ▶ Using a small screwdriver remove the batteries from their holder.
- ▶ Place new batteries into the holders.
- ▶ Place the enclosure cover back on its position paying attention to not bend the LEDs.
- ▶ Fix the cover with the 4 back screws.

Power backup batteries:

2 x AAA NiMh rechargeable batteries, 1.2V

RTC backup battery:

1 x CR1220 coin cell, 3V



Ensure the LEDs are well aligned with the cover holes before closing the enclosure.

11 Troubleshooting

Problem: RF link down alarm from IDAM and/or DAM

- Ensure there are no shielding (especially metallic walls) in between the DAM and the CU.
- Ensure no other **BATTMASTER**® system is using the same RF channel nearby.
- Run the RF diagnostic tool (§8.3.10) and check the signal quality. If the signal is bad, move the CU closer.
- Replace the DAM if none of the above works.

Problem: CU not discovered automatically on network

- Discovery only works if the CU and the **BATTMASTER**® software are connected to the same network because it is using broadcast packets. If not on the same network use the “**Connect to:**” button as explained on §7.2.

12 Technical specifications

12.1 Dimensions

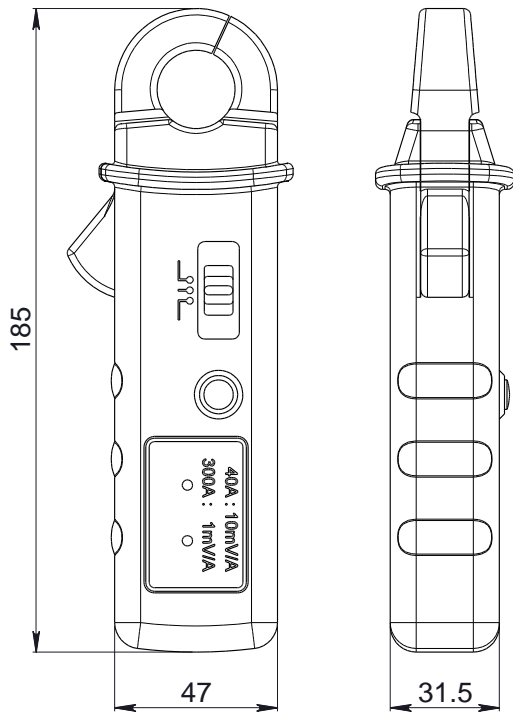


Figure 70: 300A current clamp (P/N:6032)

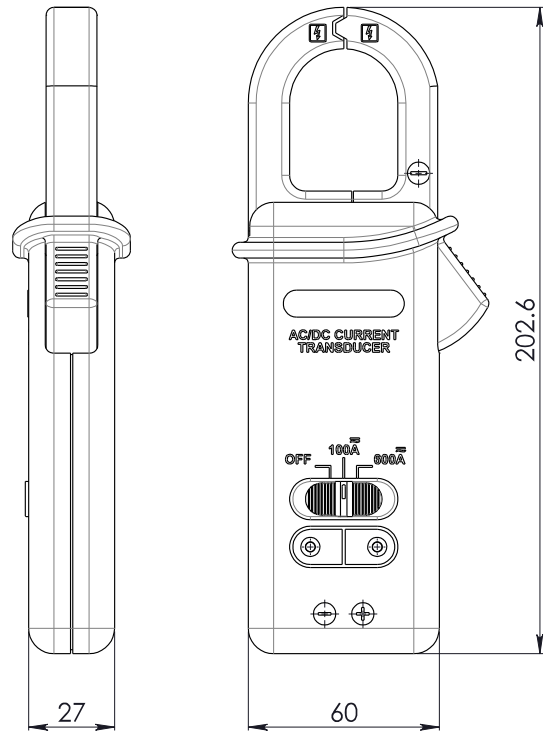


Figure 71: 600A current clamp (P/N:6034)

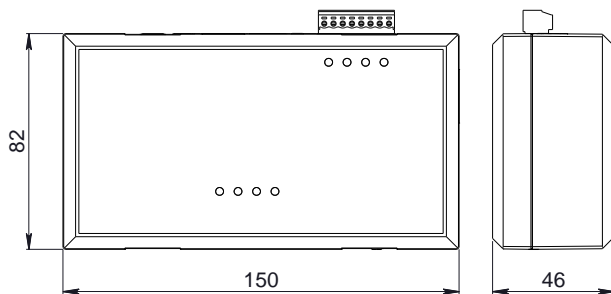


Figure 72: CU enclosure

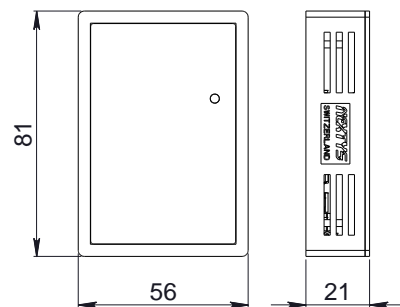


Figure 73: DAM - IDAM enclosure

12.2 General Characteristics

CU		
Supply input voltage range	4.5...5.5VDC by external power supply or by USB	
Current consumption	0.5A max.	
Weight	250g	
Plug-in AC adapter	- Input: 100..240Vac / 300mA, 50..60Hz - Output: 5Vdc / 1A	
Backup power	2X AAA NiMh rechargeable batteries (about 1.5h of backup)	
Digital inputs	- 2 x opto isolated, 5...30VDC, 10mA - Input 1: when active Real Time Logging enables - Input 2: available for future use	
Digital outputs	- 2 x relays, 30VDC 3A max - Output 1: is closed if no alarm is ongoing, open otherwise - Output 2: available for future expansion	
Data storage	FAT32 custom formatted microSD card, up to 4GB (> 2 years for 1000 batteries at refresh rate 0.5h)	
Max. number of devices	Full version	64 IDAM, 1024 DAM
	Lite version	64 IDAM, 50 DAM
Connectivity	Ethernet	- 10/100Mb - Used for remote configuration and monitoring - HTTP server and SMTP client
	Modbus/TCP	- Remote Monitoring - Real Time Logging enable
	USB2	- Full speed 12Mbit/s - Used for remote configuration and monitoring
	GSM	- Quad-Band 850/900/1800/1900MHz - SMS alarms
	RF	- 868.00-868.60MHz, Max EIRP 4mW, 3 channels user settable - Up to 100 meters outdoor, up to 30 meters indoor

DAM		L type (2V batteries)	H type (6/12V batteries)
Battery voltage range		1.5...5.5VDC	5...18VDC
Current consumption (typical)		80mA @ 2V (Sleep mode: 9mA)	30mA @ 12V (Sleep mode: 4mA)
Weight		40g	
RF		- 868.00-868.60MHz, Max EIRP 4mW, 3 channels user settable - Up to 100 meters outdoor, up to 30 meters indoor	
Battery Measures	Voltage	1.5...5.5VDC, $\pm 1.5\%$	5...18V, $\pm 1.5\%$
	Ri	1...300m Ω , $\pm 10\%$ or $\pm 1m\Omega$	
	Temperature	- 20...80°C, $\pm 2^\circ\text{C}$	
Protections		-Reverse polarity (active) -Overvoltage (passive)	
Battery connection		Blade connector (Faston), ring or alligator clip; others possible on demand	
IDAM		Type 1 (300A)	Type 2 (600A)
Supply input range		9...18VDC(from external power supply or battery)	
Current consumption (typical)		50mA @ 12V (Sleep mode: 15mA)	
Plug-in AC adapter		- Input: 100..240Vac / 500mA, 50..60Hz - Output: 12Vdc / 1.67A	
RF		- 868.00-868.60MHz, Max EIRP 4mW, 3 channels user settable - Up to 100 meters outdoor, up to 30 meters indoor	
Current Range		40A range: 0...40A, $\pm(1.5\% + 0.4A)$ 300A range: 0...200A, $\pm(1.5\% + 2A)$	100A range: 0...100A, $\pm(3\% + 3A)$ 600A range: 0...400A, $\pm(3\% + 4A)$

	200...300A, $\pm(2.4\% +3A)$	400...600A, $\pm(4\% +4A)$
Weight	- IDAM module: 40g - Current clamp: 200g	- IDAM module: 40g - Current clamp: 250g
Protections	- Reverse polarity (active) - Overvoltage (passive)	

Table 4: Devices characteristics

Note: Referred values are typical. In order to improve the product, specifications may change without prior notice.