

General Safety Instructions:

READ SAFETY INSTRUCTIONS

Servicing:

These products are not customer serviceable TDK-Lambda UK LTD and their authorised agents only are permitted to carry out repairs.

Critical Components:

These products are not authorised for use as critical components in nuclear control systems, life support systems or equipment for use in hazardous environments without the express written approval of the Managing Director of TDK-Lambda EMEA.

Product Usage:

These products are designed for use within a host equipment which restricts access to authorised competent personnel.

This product is a component power supply and is only to be installed by qualified persons within other equipment and must be not operated as a stand alone product.

This product is for sale to business to business customers and can be obtained via distribution channels. It is not intended for sale to end users.

This product is a component power supply and does not fall within the scope of the EMC directive. Compliance with the EMC directive must be considered in the final installation. Please contact your local TDK-Lambda office.

Environmental:

These products are IPX0, and therefore chemicals/solvents, cleaning agents and other liquids must not be used.

Environment:

This power supply is a switch mode power supply for use in applications within a Pollution Degree 2, overvoltage category II environment. Material Group IIIb PCB's are used within it.

Output Loading:

The output power taken from the power supply must not exceed the rating stated on the power supply label, except as stated in the product limitations in this handbook.

Input Parameters:

This product must be operated within the input parameters stated in the product limitations in this handbook.

End of Life Disposal:

The unit contains components that require special disposal. Make sure that the unit is properly disposed of at the end of its service life and in accordance with local regulations.



RISK OF ELECTRIC SHOCK

High Voltage Warning:

Dangerous voltages are present within the power supply. The professional installer must protect service personnel from inadvertent contact with these dangerous voltages in the end equipment.

WARNING: When installed in a Class 1 end equipment, this product must be reliably earthed and professionally installed.

The (+) or (-) output(s) can be earthed or left floating.

The unit cover(s)/chassis (where applicable) must not be made user accessible.

The mains input connector is not acceptable for use as field wiring terminals.

For encased products, do not use mounting screws, which penetrate the unit more than; See drawings.

Internal fuses protect the unit and must not be replaced by the user. In case of internal defect, the unit must be returned to TDK-Lambda UK LTD or one of their authorised agents.

A suitable mechanical, electrical and fire enclosure must be provided by the end use equipment for mechanical, electric shock and fire hazard protection.

Energy Hazards:

The main output of this product is capable of providing hazardous energy (240VA). Final equipment manufacturers must provide protection to service personnel against inadvertent contact with the output terminals.

The unit cover/chassis, where applicable, is designed to protect skilled personnel from hazards. They must not be used as part of the external covers of any equipment where they may be accessible to operators, since under full load conditions, part or parts of the unit chassis may reach temperatures in excess of those considered safe for operator access.

Allgemeine Sicherheitsvorschriften:

LESEN SIE DIE SICHERHEITSVORSCHRIFTEN

Wartung:

Diese Produkte können nicht durch den Kunden gewartet werden. Nur TDK-Lambda UK LTD. und deren zugelassene Vertriebshändler sind zur Durchführung von Reparaturen berechtigt.

Kritische Komponenten:

Diese Produkte sind nicht für die Verwendung als kritische Komponenten in nuklearen Kontrollsystemen, Lebenserhaltungssystemen oder Geräten in gefährlichen Umgebungen geeignet, sofern dies nicht ausdrücklich und in Schriftform durch den Geschäftsführer von TDK-Lambda EMEA genehmigt wurde.

Produktverwendung:

Diese Produkte sind zur Verwendung innerhalb von Host-Anlagen gedacht, die einen auf das Fachpersonal beschränkten Zugang haben.

Dieses Produkt ist eine Stromversorgungs-Komponente und sie darf nur von qualifiziertem Personal in andere Geräte eingebaut werden und sie darf NICHT als eigenständiges ("Stand-Alone") Gerät betrieben werden.

Dieses Produkt ist für den Verkauf an Geschäftskunden entwickelt worden und es kann über Distributionskanäle bezogen werden.

Es ist NICHT für den Verkauf an Endkunden gedacht und konzipiert.

Dieses Produkt ist eine Stromversorgungsbaugruppe und sie fällt NICHT in den Bereich der EMV Direktive.

Die Konformität mit der EMV Richtlinie muss in der finalen Gesamtinstallation betrachtet werden.

Bitte kontaktieren Sie Ihr regionales TDK-Lambda Vertriebsbüro im Falle von Rückfragen.

Umwelt:

Diese Produkte sind IPX0, aus diesem Grund dürfen keine Chemikalien/Lösungsmittel, Reinigungsmittel und andere Flüssigkeiten verwendet werden.

Umgebung:

Dieses Netzteil ist ein Schaltnetzteil zur Verwendung in einer Umgebung mit einem Verschmutzungsgrad 2, Überspannungskategorie II. Materialgruppe IIIb mit darin verwendeten PCBs.

Ausgangsstrom:

Der Ausgangsstrom des Netztesles darf die Leistung, die auf dem Label des Netztesles vermerkt ist, nur dann überschreiten, wenn dies in den Produktgrenzen dieses Handbuches ausgezeichnet ist.

Eingangsparameter:

Dieses Produkt muss innerhalb der Eingangsparameter, die in den Produktgrenzen dieses Handbuches angegeben sind, betrieben werden.

Entsorgung am Ende der Betriebszeit:

Das Gerät enthält Komponenten die unter Sondermüll fallen. Das Gerät muss am Ende der Betriebszeit ordnungsgemäß und in Übereinstimmung mit den regionalen Bestimmungen entsorgt werden.

**GEFAHR DURCH ELEKTRISCHEN SCHLAG****Hochspannungswarnung:**

Innerhalb des Netztesles gibt es gefährliche Spannungen. Der Elektroinstallateur muss das Wartungspersonal vor versehentlichem Kontakt mit den gefährlichen Spannungen im Endgerät schützen.

WARNUNG! Falls Sie unser Netzgerät in eine Anwendung mit Schutzklasse 1 eingebaut haben, stellen Sie sicher, dass es fachgerecht installiert und zuverlässig geerdet ist.

Die (+) oder (-) Ausgänge können geerdet werden oder unangeschlossen bleiben.

Die Abdeckung des Gerätes/das Gehäuse darf für den Benutzer nicht zugänglich sein.

Der Haupteingangsanschluss ist nicht für die Verwendung als Feldverdrahtungsanschluss geeignet.

Für ummantelt Produkte, verwenden Sie keine Schrauben, die das Gerät mehr als durchdringen; siehe Zeichnung. Eine interne Sicherung schützt das Gerät und darf durch den Benutzer nicht ausgetauscht werden. Im Fall von internen Defekten muss das Gerät an TDK-Lambda UK LTD oder einen der autorisierten Vertriebs Händler zurückgeschickt werden.

Ein geeignetes mechanisches, elektrisches und brandgeschütztes Gehäuse muss als Schutz vor der Gefahr von mechanischen Risiken, Stromschlägen und Brandschutz in dem Endgerät vorgesehen werden.

Gefahren durch elektrische Energie:

Von bestimmten Modulen kann je nach Einstellung der Ausgangsspannung gefährliche elektrische Energie ausgehen (240 VA). Die Endgerätehersteller müssen einen Schutz für Servicepersonal vor unbeabsichtigtem Kontakt mit den Ausgangsanschlüssen dieser Module vorsehen. Kann aufgrund der Einstellung gefährliche elektrische Energie auftreten, dürfen die Modulanschlüsse für den Benutzer nicht zugänglich sein.

Die Geräteabdeckung/das Gehäuse ist so entworfen, dass das Fachpersonal vor Gefahren geschützt wird. Sie dürfen nicht als Teil der externen Abdeckung für Geräte verwendet werden, die für den Betreiber zugänglich sein müssen, da Teile oder das gesamte Gerätegehäuse unter voller Auslastung übermäßige Temperaturen erreichen kann, die für den Zugang des Betreibers nicht mehr als sicher betrachtet werden.

Consignes générales de sécurité:

LIRE LES CONSIGNES DE SECURITE

Entretien:

Ces produits ne peuvent pas être réparés par l'utilisateur. Seuls, TDK-Lambda UK LTD et ses agents agréés sont autorisés à effectuer des réparations.

Composants critiques:

Ces produits ne doivent pas être utilisés en tant que composants critiques dans des systèmes de commande nucléaire, dans des systèmes de sauvetage ou dans des équipements utilisés dans des environnements dangereux, sans l'autorisation écrite expresse du directeur général de TDK-Lambda EMEA.

Utilisation du produit:

Ces produits sont conçus pour être utilisés dans un équipement hôte dont l'accès n'est autorisé qu'aux personnes compétentes.

Ce produit est une alimentation considérée comme un composant devant être installé par des personnes qualifiées, dans un autre équipement. Il ne doit pas être utilisé en tant que produit fini.

Ce produit est destiné à la vente entre entreprises et peut être obtenu via des canaux de distribution.

Il n'est pas prévu à la vente pour les particuliers.

Ce produit est une alimentation considérée comme un composant, il ne relève pas du champ d'application de la directive CEM. Le respect de la directive CEM doit être pris en compte dans l'installation finale. Veuillez contacter votre bureau TDK-Lambda le plus proche.

Environnement:

Ces produits sont IPX0, et donc on ne doit pas utiliser des produits chimiques/solvants, des produits de nettoyage et d'autres liquides.

Environnement fonctionnel :

Cette alimentation fonctionne en mode commutation pour utilisation dans des applications fonctionnant dans un environnement avec Degré de Pollution 2 et catégorie de surtension II. Elle utilise des cartes des circuits imprimés (PCB) de Groupe IIIb.

Intensité soutirée:

L'intensité soutirée de l'alimentation ne doit pas dépasser l'intensité nominale marquée sur la plaque signalétique, sauf indications contraires dans les limitations du produit décrit dans ce manuel.

Paramètres d'entrée:

Ce produit doit être utilisé à l'intérieur des paramètres d'entrée indiqués dans les limitations du produit dans ce manuel.

Elimination en fin de vie:

L'alimentation contient des composants nécessitant des dispositions spéciales pour leur élimination. Vérifiez que cette alimentation est mise au rebut correctement en fin de vie utile et conformément aux réglementations locales en vigueur.



RISQUE DE CHOC ELECTRIQUE

Attention-Danger haute tension:

Des tensions dangereuses sont présentes dans l'alimentation. L'installateur doit protéger le personnel d'entretien contre un contact involontaire avec ces tensions dangereuses dans l'équipement final.

AVERTISSEMENT: Si ce produit est installé dans un équipement final de classe I, il doit être mis à la terre de manière fiable et installé par un professionnel averti.

Les sorties (+) ou (-) peuvent être raccordées à la terre ou laissées flottantes.

Le couvercle/châssis de l'alimentation ne doit pas être accessible à l'utilisateur. Le connecteur d'entrée d'alimentation principale ne doit pas être utilisé comme borne de raccordement.

N'utilisez pas de vis pénétrant dans le module sur une profondeur supérieure à : Voir dessins.

Un fusible interne protège le module et ne doit pas être remplacé par l'utilisateur. En cas de défaut interne, le module doit être renvoyé à TDK-Lambda UK LTD ou l'un de ses agents agréés.

Une enceinte appropriée doit être prévue par l'utilisateur final pour assurer la protection contre les chocs mécaniques, les chocs électriques et l'incendie.

Energies dangereuses :

Certains modules peuvent générer une énergie dangereuse (240 VA) selon le réglage de tension de sortie. Le fabricant de l'équipement final doit assurer la protection des techniciens d'entretien contre un contact involontaire avec les bornes de sortie de ces modules. Si une telle tension dangereuse risque de se produire, les bornes ou les connexions du module ne doivent pas être accessibles par l'utilisateur.

Le couvercle et le châssis du module sont conçus pour protéger des personnels expérimentés. Ils ne doivent pas être utilisés comme couvercles extérieurs d'un équipement, accessible aux opérateurs car en condition de puissance maximum, des parties du châssis peuvent atteindre des températures considérées comme dangereuses pour l'opérateur.

Norme generali di sicurezza:

SI PREGA DI LEGGERE LE NORME DI SICUREZZA

Manutenzione:

Il cliente non può eseguire alcuna manutenzione su questi prodotti. L'esecuzione delle eventuali riparazioni è consentita solo a TDK-Lambda UK LTD e ai suoi agenti autorizzati.

Componenti critici:

Non si autorizza l'uso di questi prodotti come componenti critici all'interno di sistemi di controllo nucleari, sistemi necessari alla sopravvivenza o apparecchiature destinate all'impiego in ambienti pericolosi, senza l'esplicita approvazione scritta dell'Amministratore Delegato di TDK-Lambda EMEA.

Uso dei prodotti:

Questi prodotti sono progettati per l'uso all'interno di un'apparecchiatura ospite che limiti l'accesso al solo personale competente e autorizzato.

Questo prodotto è da considerarsi come un alimentatore professionale componente e come tale deve essere installato da personale qualificato all'interno di altre apparecchiature e non può essere utilizzato come prodotto indipendente.

Questo prodotto non è inteso per la vendita al dettaglio o agli utilizzatori finali.

Questo alimentatore è da considerarsi come un componente e come tale non è assoggettato dagli scopi della direttiva EMC. Conformità alla direttiva EMC deve essere considerata nell'installazione finale di utilizzo. Gli uffici di TDK-Lambda Sas Succursale Italiana sono a vostra disposizione per ulteriori raggugli.

Condizioni ambientali:

Questi prodotti sono classificati come IPX0, dunque non devono essere utilizzati sostanze chimiche/solventi, prodotti per la pulizia o liquidi di altra natura.

Ambiente:

Questo prodotto è un alimentatore a commutazione, destinato all'uso in applicazioni rientranti in ambienti con le seguenti caratteristiche: Livello inquinamento 2, Categoria sovratensione II. Questo prodotto contiene schede di circuiti stampati in materiali di Gruppo IIIb.

Carico in uscita:

La potenza in uscita ottenuta dall'alimentatore non deve superare la potenza nominale indicata sulla targhetta dell'alimentatore, fatto salvo dove indicato nei limiti per il prodotto specificati in questo manuale.

Parametri di alimentazione:

Questo prodotto deve essere utilizzato entro i parametri di alimentazione indicati nei limiti per il prodotto, specificati in questo manuale.

Smaltimento:

L'unità contiene componenti che richiedono procedure speciali di smaltimento. Accertarsi che l'unità venga smaltita in modo corretto al termine della vita utile e nel rispetto delle normative locali.



RISCHIO DI SCOSSA ELETTRICA

Avvertimento di alta tensione:

All'interno dell'alimentatore sono presenti tensioni pericolose. Gli installatori professionali devono proteggere il personale di manutenzione dal rischio di contatto accidentale con queste tensioni pericolose all'interno dell'apparecchiatura finale.

ATTENZIONE: Se installato in un'attrezzatura di classe I, questo prodotto deve essere collegato a terra in modo affidabile ed installato in modo professionale.

Le uscite (+) o (-) possono essere messa a terra o lasciate isolate.

I coperchi/il telaio dell'unità non devono essere accessibili da parte dell'utente.

Il connettore dell'alimentazione principale non può essere utilizzato come terminale di collegamento di campo.

Non utilizzare viti che penetrano nell'unità per più di : Vedi disegni

Un fusibile interno protegge l'unità e non deve essere sostituito dall'utente. Nell'eventualità di un difetto interno, restituire l'unità a TDK-Lambda UK LTD o a uno dei suoi agenti autorizzati.

L'apparecchiatura finale deve includere una recinzione meccanica, elettrica e antincendio per proteggere dai pericoli di natura meccanica, dalle scosse elettriche e dai pericoli di incendio.

Pericoli energetici:

Alcuni moduli sono in grado di erogare energia pericolosa (240 VA) a seconda della tensione in uscita impostata. I produttori delle apparecchiature finali sono tenuti a proteggere il personale di manutenzione dal rischio di contatto accidentale con questi terminali dei moduli di uscita. Se impostati su livelli che non escludono l'erogazione di energia pericolosa, questi terminali o collegamenti non devono risultare accessibili da parte dell'utente.

Il coperchio/telaio dell'unità è realizzato per proteggere il personale esperto dai pericoli. Non deve essere usato come parte degli involucri esterni di qualsiasi apparecchiatura, se risulta accessibile da parte degli addetti, poiché è possibile che in condizioni di pieno carico una o più parti del telaio dell'unità giunga/giungano a temperature superiori ai limiti considerati sicuri per l'accesso da parte degli addetti.

Instrucciones generales de seguridad:

LEA LAS INSTRUCCIONES DE SEGURIDAD

Servicio:

Estos productos no pueden ser reparados por los clientes. TDK-Lambda UK LTD. y sus agentes autorizados son los únicos que pueden llevar a cabo las reparaciones.

Componentes fundamentales:

Estos productos no pueden ser utilizados como componentes fundamentales en sistemas de control nuclear, sistemas de soporte vital o equipos a utilizar en entornos peligrosos sin el consentimiento expreso por escrito del Director General de TDK-Lambda EMEA.

Uso de los productos:

Estos productos han sido diseñados para ser utilizados en un equipo central que restrinja el acceso al personal cualificado autorizado.

Este producto es una fuente de alimentación y sólo puede ser instalado por personal cualificado dentro de otros equipos y no debe ser tratado como un producto independiente. Este producto debe ser vendido entre empresas profesionales y solo puede obtenerse a través de los canales de distribución. No está destinado para la venta a usuarios finales

Este producto es una fuente de alimentación y no se ve afectada por la directiva EMC. El cumplimiento de la directiva EMC se debe considerar en la instalación final. Por favor, póngase en contacto con su oficina local de TDK – Lambda.

Medioambiental:

Estos productos son IPX0 y, por tanto, no pueden utilizarse sustancias químicas/disolventes, agentes de limpieza ni otros líquidos.

Medio ambiente:

Esta fuente de alimentación es una fuente de alimentación de modo conmutado a utilizar en aplicaciones dentro de un entorno con un Grado de contaminación 2 y una Categoría de sobretensión II. En él se utilizan policloruros de bifenilo del Grupo de materiales IIIb.

Carga de salida:

La potencia de salida tomada de la fuente de alimentación no puede sobrepasar el valor nominal indicado en la etiqueta de la fuente de alimentación, excepto en los casos indicados en las limitaciones del producto en este manual.

Parámetros de entrada:

Este producto debe ser utilizado dentro de los parámetros de entrada indicados en las limitaciones del producto en este manual.

Desecho de la unidad:

La unidad contiene componentes que deben ser desechados de una manera especial. Asegúrese de desechar correctamente la unidad al final de su vida útil y conforme a las normas locales vigentes.



PELIGRO DE DESCARGAS ELÉCTRICAS

Advertencia de alta tensión:

En esta fuente de alimentación hay tensiones peligrosas. El instalador profesional debe proteger al personal de servicio contra cualquier contacto accidental con estas tensiones peligrosas en el equipo final.

ADVERTENCIA: La instalación de este producto en un equipo de clase I la deben llevar a cabo profesionales y el producto debe estar conectado a tierra.

La salida o salidas (+) o (-) pueden conectarse a tierra o se las puede dejar flotando.

Debe impedirse el acceso de los usuarios a la cubierta o cubiertas y al chasis de la unidad.

El conector de entrada de la red no es apto para ser utilizado a modo de bornes de cableado de campo.

No utilice tornillos de montaje susceptibles de penetrar en la unidad más de: Ver dibujos.

Un fusible interno protege la unidad y este no debe ser nunca reemplazado por el usuario. En caso de existir algún defecto interno, la unidad debe ser enviada a TDK-Lambda UK LTD o a uno de sus agentes autorizados.

El equipo de uso final debe constituir un recinto de protección mecánica, eléctrica y contra incendios de protección mecánica, contra descargas eléctricas y contra el peligro de incendios.

Peligros de energía:

Algunos módulos pueden generar energía peligrosa (240VA) dependiendo de la configuración de la tensión de salida. Los fabricantes de equipos finales deben proteger al personal de servicio contra un contacto accidental con estos bornes de salida de los módulos. Si se configura de modo que pueda generarse energía peligrosa, hay que evitar que el usuario pueda acceder a los bornes o conexiones del módulo.

La cubierta/chasis de la unidad ha sido diseñada para que proteja a las personas cualificadas de los peligros. No deben ser utilizadas como parte de las cubiertas externas de cualquier equipo al que pueden acceder los operarios, ya que bajo unas condiciones de carga completa, la pieza o piezas del chasis de la unidad pueden alcanzar temperaturas superiores a las consideradas seguras para el acceso de los operarios.

Instruções gerais de segurança:

LEIA AS INSTRUÇÕES DE SEGURANÇA

Manutenção:

Estes produtos não são podem ser submetidos a manutenção por parte do cliente. Apenas a TDK-Lambda UK LTD e os seus agentes autorizados têm permissão para realizar reparações.

Componentes essenciais:

Não é autorizada a utilização destes produtos como componentes essenciais de sistemas de controlo nuclear, sistemas de suporte de vida ou equipamento para utilização em ambientes perigosos sem a expressa autorização por escrito do Director-Geral da TDK-Lambda EMEA.

Utilização do produto:

Estes produtos foram concebidos para utilização dentro de um equipamento de alojamento que apenas permita o acesso a pessoal qualificado autorizado.

Este produto é uma alimentação considerado com um componente para ser instalado por pessoas qualificadas, em outros equipamentos. Não deve ser usado como um produto acabado.

Este produto é destinado para venda entre as empresas e pode ser obtido através de canais de distribuição.

Não se destina à venda aos particulares.

Este produto é uma alimentação considerado com um componente, não é dentro do application âmbito da directiva CEM.

Conformidade com a directiva CEM devem ser considerados na instalação final.

Entre em contacto com seu escritório TDK-Lambda mais próximo.

Ambiental:

Estes produtos são IPX0 e, como tal, não se devem utilizar químicos/solventes, agentes de limpeza e outros líquidos.

Ambiente:

Esta fonte de alimentação é uma fonte de alimentação do modo de comutação para utilização em aplicações com um Nível de Poluição 2 e ambientes da categoria de sobretensão II. São utilizadas placas de circuitos impressos do grupo de materiais IIIb.

Carga de saída:

A potência de saída extraída da fonte de alimentação não deve exceder a classificação assinalada na etiqueta da fonte de alimentação, excepto quando indicado nas limitações do produto neste guia.

Parâmetros de entrada:

Este produto deve ser utilizado dentro dos parâmetros de entrada indicados nas limitações do produto neste guia.

Eliminação no fim de vida:

A unidade contém componentes que necessitam de procedimentos especiais de eliminação. Certifique-se de que a unidade é devidamente eliminada no fim da sua vida útil e que tal é feito em conformidade com os regulamentos locais.



RISCO DE CHOQUE ELÉCTRICO

Aviso de alta tensão:

Estão presentes tensões perigosas dentro da fonte de alimentação. O profissional que realizar a instalação deve proteger o pessoal de assistência contra contactos inadvertidos com estas tensões perigosas do equipamento final.

AVISO: Quando instalado num equipamento de Classe I, este produto deve ser ligado à terra de forma fiável e instalado por um profissional.

As saídas (+) e (-) podem ser ligadas à terra ou deixadas soltas.

O chassis/cobertura(s) da unidade não deve estar acessível ao utilizador.

O conector de entrada de alimentação não deve ser utilizado como terminal de cablagens no local.

Não utilize parafusos de montagem, uma vez que estes penetrarão na unidade em mais do que: Veja os desenhos

Existe um fusível interno que protege a unidade e que não deve ser substituído pelo utilizador. Em caso de defeito interno, a unidade deve ser devolvida à TDK-Lambda UK LTD ou a um dos seus agentes autorizados.

O equipamento de utilização final deve fornecer um bastidor com protecção mecânica, eléctrica e contra incêndios adequada.

Perigos de energia:

Alguns módulos tem a capacidade de fornecer energia perigosa (240 VA), de acordo com a configuração da tensão de saída. O equipamento final do fabricante deve garantir que o pessoal de assistência está protegido contra contactos inadvertidos com estes terminais de saída do módulo. Se essa energia perigosa for produzida, as ligações e os terminais do módulo não devem ser acessíveis pelos utilizadores.

O chassis/cobertura da unidade está concebido de forma a proteger o pessoal especializado de perigos. Não devem ser utilizados como parte das coberturas externas de qualquer equipamento em que possam estar acessíveis aos operadores, uma vez que em condições de carga máxima, algumas peças do chassis da unidade podem atingir temperaturas superiores às consideradas seguras para o acesso do operador.

TDK-Lambda

TDK-Lambda UK Ltd

Kingsley Avenue, Ilfracombe

Devon, EX34 8ES

Telephone - Sales and Service +44 (0)1271 856666

Head Office and Works +44 (0)1271 856600

Facsimile +44 (0)1271 864894

WEBSITE: www.uk.tdk-lambda.com

EZA2500 Series

COMMUNICATION MANUAL

BEFORE USING THE POWER SUPPLY UNIT (Common)

Be sure to read this instruction manual thoroughly before using this product. Pay attention to all cautions and warnings before using this product. Incorrect usage could lead to an electrical shock, damage to the unit or a fire hazard.

DANGER

Never use this product in locations where flammable gas or ignitable substances are present.

INSTALLATION WARNING

- When installing, ensure that work is done in accordance with the instruction manual. When installation is improper, there is risk of electric shock and fire.
- Installation shall be done by Service personnel with necessary and appropriate technical training and experience. There is a risk of electric shock and fire.
- Do not cover the product with cloth or paper etc. Do not place anything flammable around. This might cause damage, electric shock or fire.

WARNING on USE

- Do not touch this product or its internal components while circuit in operation, or shortly after shutdown. You may receive a burn.
- While this product is operating, keep your hands and face away from it as you may be injured by an unexpected situation.
- There are cases where high voltage charge remains inside the product. Therefore, do not touch even if they are not in operation as you might get injured due to high voltage and high temperature.
You might also get electric shock or burn.
- Do not make unauthorized changes to this product nor remove the cover as you might get an electric shock or might damage the product. We will not be held responsible after the product has been modified, changed or dis-assembled.
- Do not use this product under unusual condition such as emission of smoke or abnormal smell and sound etc. Please stop using it immediately and shut off the product.
It might lead to fire and electric shock. In such cases, please contact us. Do not attempt repair by yourself, as it is dangerous for the user.
- Do not operate and store these products in environments where condensation occurs due to moisture and humidity. It might lead fire and electric shock.
- Do not drop or apply shock to this product. It might cause failure. Do not operate these products mechanical stress is applied.

CAUTION on MOUNTING

- Confirm connections to input/output terminals are correct as indicated in the instruction manual before switching on.
- Input voltage, Output current, Output power, ambient temperature and ambient humidity should be kept within specifications, otherwise the product will be damaged, or cause electric shock or fire.
- Do not use this product in special environment with strong electromagnetic field, corrosive gas or conductive substances and direct sunlight, or places where product is exposed to water or rain.
- Mount this product properly in accordance with the instruction manual, mounting direction and shall be properly be ventilated.
- Please shut down the input when connecting input and output of the product.
- The power supply may cause damage when it intake conductive material, dust and liquid. When use this product, please be careful to prevent entry of those materials to inside the product by using filter etc.
- Do not use this product in environments where causes the salt damage.

CAUTION on USE

- Product individual notes are shown in the instruction manual. If there is any difference with common notes individual notes shall have priority.
- Before using this product, be sure to read the catalog and instruction manual. There is risk of electric shock or damage to the product or fire due to improper use.
- Input voltage, Output current, Output power, ambient temperature and ambient humidity should be kept within specifications, otherwise the product will be damaged, or cause electric shock or fire.
- If the built-in fuse is blown, do not use the product even after replacing the fuse as there is risk of abnormality inside. Be sure to request repair to our company.

- For products without built-in protection circuit (element, fuse, etc.), insert fuse at the input to prevent smoke, fire during abnormal operation.
As for products with built-in protection circuit, depending on usage conditions, built-in protection circuit might not work. It is recommended to provide separate proper protection circuit.
- For externally mounted fuse do not use other fuses aside from our specified and recommended fuse.
- This product was made for general purpose electronic equipment for standard industrial use and is not designed for applications requiring high safety (such as extremely high reliability and safety requirements. Even though high reliability and safety are not required, this product should not be used directly for applications that have serious risk for life and physical safety. Take sufficient consideration in fail-safe design (such as providing protective circuit or protective device inside the system, providing redundant circuit to ensure no instability when single device failure occurs).
- When used in environments with strong electromagnetic field, there is possibility of product damage due to malfunction.
- When used in environment with corrosive gas (hydrogen sulfide, sulfur dioxide, etc.) , there is possibility that they might penetrate the product and lead to failure.
- When used in environments where there is conductive foreign matter or dust, there is possibility of product failure or malfunction.
- Provide countermeasure for prevention of lightning surge voltage as there is risk of damage due to abnormal voltage.
- Connect together the frame ground terminal of the product and the ground terminal of the equipment for safety and noise reduction. If these ground is not connected together, there is risk of electric shock.
- Parts with lifetime specifications (built-in fan, electrolytic capacitor) are required to be replaced periodically.
Set the overhaul period depending on the environment of usage and perform maintenance.
Also, note that there are cases when EOL products cannot be overhauled.
- Take care not to apply external abnormal voltage to the output. Especially, applying reverse voltage or overvoltage more than the rated voltage to the output might cause failure, electric shock or fire.
- Do not use in special environment such as places directly exposed to sunlight, dew condensation, moisture, rain, strong electro-magnetic field, or corrosive gas (hydrogen sulfide, sulfur dioxide).
- This product have a built-in fan for air-cooling. Do not block the air intake and exhaust.
- The output of this product is considered to be a hazardous energy level (The voltage is 2V or more and the power is 240VA or more). It must not be made accessible to users. Protection must be provided for Service Engineers against indirect contact with the output terminals and/or to prevent tools being dropped across them. While working on this product, the DC input power must be switched off and the input and output voltage should be zero.
- When short the output during operation, there is a damage inside the converter.
- When change abrupt in Input voltage during operation, there is a Risk of damage inside the converter.
- When use the Electric storage device, Please refer to the manual of electric storage device and use the appropriate protection device.

 **Note**

- There is a possibility machining traces remain on sheet metal of product.
- Consider storage of the product at normal temperature and humidity avoiding direct exposure to sunlight at environment with minimal temperature and humidity changes. Storage of product at high temperature, high humidity and environments with severe changes in temperature and humidity might cause deterioration, and occurrence of condensation in the product.
- When disposing product, follow disposal laws of each municipality.
- Published EMI (CE, RE) or immunity is the result when measured in our standard measurement conditions and might not satisfy specification when mounted and wired inside end-user equipment.
Use the product after sufficiently evaluating at actual end-user equipment.
- Catalogue, contents of the instruction manual may be changed without a prior notice. Refer to latest catalogue or instruction manual.
- Reproduction or reprinting the instruction manual or its portion is forbidden without our permission.

Contents

■ Communication Specification

- 1.RS-485 communication specification
- 2.Serial communication connector
- 3.Serial Connection of Multiple Converters
- 4.Setting for communication address
- 5.Setting by DIP switch
- 6.Communication Protocol
- 7.Data format
- 8.Example of setting by communication

■ Command/Response Table

- 1.Table of command/response code
- 2.Table of communication error code

■ Setting parameter table

- 1.Setting parameter table about operation mode
- 2.Setting parameter table

■ Command reference

1. Operation Mode
 - 1-1 Inquire Operation Mode
 - 1-4 Set Operation Mode
2. Converter Status
 - 2-1 Inquire Converter Status
3. CV Charging Parameter
 - 3-1 Read CV Charging Parameter
 - 3-4 Write CV Charging Parameter
4. CV Discharging Parameter
 - 4-1 Read CV Discharging Parameter
 - 4-4 Write CV Discharging Parameter
5. Dead Zone Parameter
 - 5-1 Read Dead Zone Parameter
 - 5-4 Write Dead Zone Parameter
6. Converter Protection Parameter
 - 6-1 Read Converter Protection Parameter
 - 6-4 Write Converter Protection Parameter
7. Battery Configuration Parameter1
 - 7-1 Read Battery Configuration Parameter1
 - 7-4 Write Battery Configuration Parameter1
- 8 Battery Configuration Parameter2
 - 8-1 Read Battery Configuration Parameter2
 - 8-4 Write Battery Configuration Parameter2
9. Alarm
 - 9-1 Inquire Alarm
 - 9-4 Clear Alarm
10. Converter Meter1
 - 10-1 Read Converter Meter1

11. Converter Meter2

- 11-1 Read Converter Meter2

12. Converter Meter1 Format

- 12-1 Read Converter Meter1 Format

13. Converter Meter2 Format

- 13-1 Read Converter Meter2 Format

14. Nominal Value

- 14-1 Read Nominal Value

15. Interface Firmware Version

- 15-1 Read Interface Firmware Version

16. Control Firmware Version

- 16-1 Read Control Firmware Version

■ BCF Parameter

- 1.Function
- 2.Related parameters
- 3.Setting table about BCF

Communication Specification

This device has interface for communication with external device.

This device can operate following items by serial communication(RS-485).

- ON/OFF operation of power conversion by Manual control (charge/discharge) or Automatic control.
- Change value for operation setting (target voltage for charge/discharge, limited current for charge/discharge, etc.)
- Get device information (Device status, Alarm information, etc.)

Settings is saved in the internal memory, so it is also valid at next startup.

1.RS-485 communication specification

1 Device specifications

No	Item	Specification	Comment
1.1	Figure of connector	RJ-45	Commodity for LAN connector
1.2	Pin assign	A(+), B(-), GND [refer below figure]	
1.3	Amount of connector	2	Cascaded at device internally
1.4	Cable	Twisted pair cable with shield.	Recommend STP cable for LAN

2 Electrical specifications

No	Item	Specification	Comment
2.1	Power supply for comm.	Device has. (isolated with device GND)	Functional isolation
2.2	Signal level	5V	
2.3	Transmission	half duplex	
2.4	Network bandwidth	1Mbps Max	
2.5	Terminator	Device not has	Connect registers(120Ω) at both ends of comm bus, If you need.

3 Transmission character specifications

No	Item	Specification	Comment
3.1	Inquiry converter status.	start-stop synchronization	
3.2	baud rate	9600 / 19.2K / 38.4K / 57.6K bps	
3.3	signaling parameter	data length 8bit, parity none, start 1bit, stop 1bit	
3.4	Flow control	none	

4 Others

No	Item	Specification	Comment
4.1	Response time (Max)	80ms (at 9600bps)	Between received command and starting operation.
		60ms (at 19.2Kbps)	
		50ms (at 38.4Kbps)	
		50ms (at 57.6Kbps)	
4.2	Interval time (Min)	2ms	Between sent response and starting receive.

2.Serial communication connector

This device use RS-485 interface communicating with management device.

Connector is RJ-45(with shield), it's commodity for LAN connector.

Below figure shows pin layout at back panel.

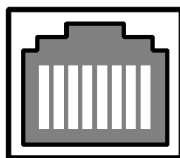

87654321

Pin #	Signal	Note
1	NC	No use
2	NC	No use
3	NC	No use
4	D1	B (Inverted diffirential pair)
5	D0	A (Non-inverted diffirential pair)
6	NC	No use
7	NC	No use
8	Common	Common return

Cable is recommended STP cable for LAN .

Cable length is recommended less than 3m.

3.Serial Connection of Multiple Converters

In order to facilitate RS-485 connection, this converter is provided with 2 serial interface connectors. The interface circuit of this converter functions as intermediate RS-485 connectors. Due to this feature RS-485 bus can be extended simply by connecting interface cables between converters when connecting multiple converters to the host devices. (Depending on surrounding environment, there might be a need to use a termination to connect to one converter or both the converter and the host devices.)

Shown below is an example of serial connection of 4 converters.

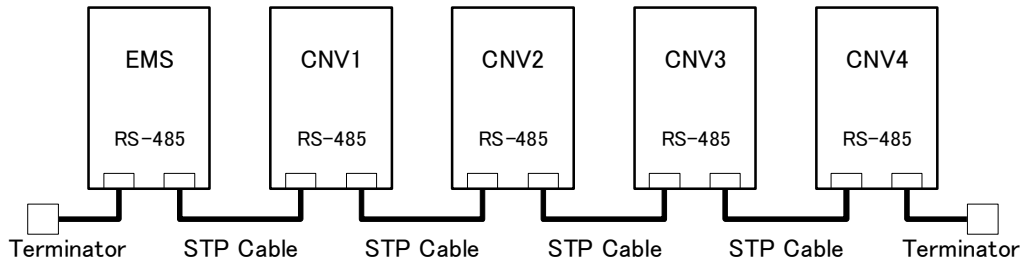

The address of converters connected to RS-485 bus including host devices should be unique. Each unique address can be set by Rotary Switch and DIP Switch. Possible address setting ranges are "0x00"~"0x7E".

Broadcast Address

Interface Address "0xFF" and Interface "0xkF"(k: 0~7) are special addresses and functions as broadcast address. When "0xFF" is set as receiver address in command sent by Host, all the converters connected within the interface bus receives that command.

When the lowest digit of the address is set to "F", all the converters within the same group receives that command. Please note that all commands sent to the Broadcast Address cannot make the response message.

Below is an example of converter address and their corresponding Broadcast Address.

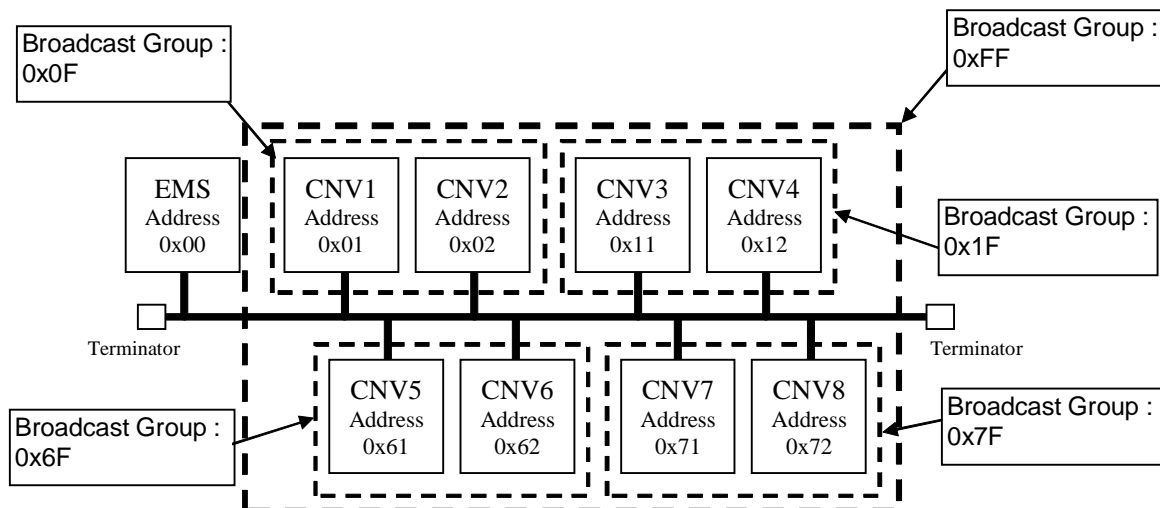

4. Setting for communication address

The rotary switch functions as the RS-485 address setting for this converter.



The interface address is composed of 7 bits and can be set within the range "0x00"~"0x7E" range. Rotary switch is used to set the lowest digits (last 4 bits) and DIP SW is used to set the highest digits. Note: The last digit address "F" is a reserved address for broadcast address and must not be used for setting address.

The value of the rotary switch is only recognized at the startup the control circuit in the converter (interface MCU initialization). If the settings are changed during converter operation, the changed setting becomes valid at the start of the next startup the control circuit in this converter.

•Bit assign of communication address

Bit	A7	A6	A5	A4	A3	A2	A1	A0
Range	"0"	0x00 - 0x70			0x00 - 0x0E			
SW type	none	DIP SW			Rotary SW			
Figure	none							

5. Setting by DIP switch

DIP Switch functions as a setting switch to designate operating mode of this converter. DIP switch is turned ON when the lever is pressed down.

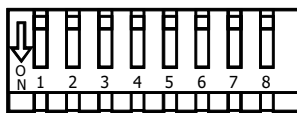

DIP SW			Operating Mode	
1	2	3	With Charging mode	With Discharging mode
OFF	OFF	OFF	Invalid *1	
OFF	OFF	ON	Manual Battery CV	Manual Grid CV
OFF	ON	OFF	Reserved	
OFF	ON	ON	Automatic Battery CV	
ON	OFF	OFF	Manual Battery CV	Automatic Grid CV
ON	OFF	ON	Manual Battery CV	Manual Grid CV with Battery CC
ON	ON	OFF	Manual Battery CV	Automatic Grid CV with Battery CC
ON	ON	ON	Reserved	

DIP SW		RS485 Baud rate *2
4	5	
OFF	OFF	19.2kbps
OFF	ON	38.4kbps
ON	OFF	57.6kbps
ON	ON	9600bps

DIP SW			RS485 Address Area *2
6	7	8	
OFF	OFF	OFF	0 : 0x00 - 0x0E
OFF	OFF	ON	1 : 0x10 - 0x1E
OFF	ON	OFF	2 : 0x20 - 0x2E
OFF	ON	ON	3 : 0x30 - 0x3E
ON	OFF	OFF	4 : 0x40 - 0x4E
ON	OFF	ON	5 : 0x50 - 0x5E
ON	ON	OFF	6 : 0x60 - 0x6E
ON	ON	ON	7 : 0x70 - 0x7E

*1 Operate by RS485 Communication only

*2 The value of the DIP Switch is only recognized at the startup the control circuit in the converter during interface MCU initialization. If the settings are changed during converter operation then the changed settings become valid at the next start up control circuit.

6.Communication Protocol

Communication data is binary.

Packet frame structure is shown bellow.

■ Command packet [Send data]

SFD	LEN	AD1	AD2	CMD	D0	...	Dx	CD0	CD1
0x05						...			

SFD: Start Frame Delimiter

Code of packet header. SFD of command packet is 0x05.

LEN : LENgth of data

Length data from Do to Dx. Range is 0x00-0x14.

AD1 : ADdress 1

Address of receiver. Range is 0x00-0x7E.

AD2 : ADdress 2

Address of sender. Range is 0x00-0x7E.

CMD : CoMmand

Command number. Range is 0x00 - 0x7F.

D0 - Dx : Data

Data fields. Little endian is used for binary data type.

16bit data : LSB MSB

32bit data : lsw.lsb lsw.msb msw.lsb msw.msb

ex)

16bit data :	0x1234	⇒	D0	D1	D2	D3
32bit data :	0x12345678		0x34	0x12		
			0x78	0x56	0x34	0x12

CD0 - CD1: Check Digit

16 bit check sum from AD1 to Dx.

Add every byte(8bits) data from AD1to Dx. And substitute result for data field as CD0 and CD1.

CD0	CD1
LSB	MSB

ex)

16bit data :	0x1234	⇒	CD0	CD1
			0x34	0x12

■ Response packet [Receive data]

SFD	LEN	AD1	AD2	CMD/RSP	D0	...	Dx	CD0	CD1
0x02						...			

SFD: Start Frame Delimiter

Code of packet header. SFD of response packet is 0x02.

LEN : LENgth of data

Length data from Do to Dx. Range is 0x00-0x14.

AD1 : ADdress 1

Address of receiver. Range is 0x00-0x7E.

AD2 : ADdress 2

Address of sender. Range is 0x00-0x7E.

CMD/RSP : command/response

Received command number. Range is 0x00 - 0x7F.

If NAK (error), Added 0x80.

D0 - Dx : Data

Data fields. Little endian is used for binary data type.

CD0 - CD1: Check Digit

16 bit check sum from AD1 to Dx.

Add every byte(8bits) data from AD1 to Dx. And substitute result for data field as CD0 and CD1.

7. Data format

■ Data formats used by this device

1. Normalized data and Normal data

Normalization that is aimed at making useful data is to modify data under defined law.
This device uses below data formats.

- Normalized data : setting data / measurements are divide by nominal value
- Normal data : setting data / measurements

2. Q format

This device uses Q format.

Q format is used to store fractional data as regular binary number (i.e. integer).

If described "Qn", "n" is the number of bits used to designate the fractional portion of the number.

(bit width - n) is the number of bits set aside to designate the integer portion of the number, exclusive of the sign bit.

ex1) 0x100 in Q6 format

bit 8	bit 7	bit 6	bit 5	bit 4	bit 3	bit 2	bit 1	bit 0
2^2	2^1	2^0	2^{-1}	2^{-2}	2^{-3}	2^{-4}	2^{-5}	2^{-6}
1	0	0	0	0	0	0	0	0

decimal point
0x100 in Q6 format is 4 in decimal.

ex2) 0x010 in Q6 format

bit 8	bit 7	bit 6	bit 5	bit 4	bit 3	bit 2	bit 1	bit 0
2^2	2^1	2^0	2^{-1}	2^{-2}	2^{-3}	2^{-4}	2^{-5}	2^{-6}
		0	0	1	0	0	0	0

decimal point
0x010 in Q6 format is 0.25 in decimal.

■ Example of normalized data in Q format

○ex1 Set target of battery voltage : Set CVB (Target Battery Voltage) to 200V

<Information for calculation>

data name	Q[n]	default	min	max	contents
CVB	14	48/48	32/48	62/48	Charging Battery Voltage

nominal value : 48

< Method for calculation >

$$\begin{aligned}
 \text{Write Value} &= \text{Setting Value} / \text{Nominal Value} \times 2^n \\
 &= 45 / 48 \times 2^{14} \\
 &= 15360 \text{ (dec)} \\
 &= 0x3C00 \text{ (hex)}
 \end{aligned}$$

< Example for write >

CVB	
D0	D1
0x00	0x3C

○ex2 Read target of grid voltage : Read DVG (Target Grid Voltage)

<Information for calculation>

data name	Q[n]	default	min	max	contents
DVG	14	320/380	260/380	400/380	Discharging Grid Voltage

nominal value : 380

< Example for read >

DVG	
D0	D1
0xA1	0x3C

< Method for calculation >

$$\begin{aligned}
 \text{Setting Value} &= \text{Read Value} \times \text{Nominal Value} / 2^n \\
 &= 0x3CA1 \text{ (hex)} \times 48 / 2^{14} \\
 &= 15521 \text{ (dec)} \times 48 / 2^{14} \\
 &= 360 \text{ (V)}
 \end{aligned}$$

Attention) nominal value in this document is value for normalization. It is not equal to rated value in specification.

8.Example of setting by communication

Example: write parameter of protection

Structure of command packet

SFD	LEN	AD1	AD2	CMD	CIB		DIG		UBV		UGV		OBV		OGV		CD0	CD1
0x05	0x0C	rcvr	sndr	0x1C	data0	data1	data2	data3	data4	data5	data6	data7	data8	data9	data10	data11	xx	xx

Example

SFD: Start Frame Delimiter

0x05 is fixed value

LEN: LENGTH of data

12 data from D0 to D11 = 0x0C

AD1-AD2: ADress

Setting bellow parameters

name	type	address
AD1(rcvr)	This device	0x00
AD2(sndr)	Host device	0x01

CMD: CoMmand

Command to write parameter of protection (0x1C)

Refer "Write Converter Protection Parameter Command"

D0-D7: Data

Setting bellow parameters (UBV~OGV)

data	description	setting value	nominal value	Q[n]
CIB	Current Limit of Battery	50	52.08	13
DIG	Current Limit of Grid	8	7.8125	13
UBV	Under Battery Volts	42	48	14
UGV	Under Grid Volts.	300	380	14
OBV	Over Baattery Volts	54	48	14
OGV	Over Grid Volts	380	380	14

Calculation to parameter (UBV~OGV)

data	calculation	result (dec)	result (hex)	D _n	D _{n+1}
CIB	$50 / 52.08 \times 2^{13}$	7864	1EB8	0xB8	0x1E
DIG	$8 / 7.8125 \times 2^{13}$	8388	20C4	0xC4	0x20
UBV	$42 / 48 \times 2^{14}$	14336	3800	0x00	0x38
UGV	$300 / 380 \times 2^{14}$	12934	3286	0x86	0x32
OBV	$54 / 48 \times 2^{14}$	18432	4800	0x00	0x48
OGV	$380 / 380 \times 2^{14}$	16384	4000	0x00	0x40

CD0, CD1: Check Digit

Add each byte data from AD1 to D11 and substitute result for data field as CD0 and CD1

$$\begin{array}{|c|} \hline \text{AD1} \\ \hline 0x00 \\ \hline \end{array}
 +
 \begin{array}{|c|} \hline \text{AD2} \\ \hline 0x01 \\ \hline \end{array}
 +
 \begin{array}{|c|} \hline \text{CMD} \\ \hline 0x1C \\ \hline \end{array}
 \dots \langle \text{omission} \rangle \dots
 \begin{array}{|c|} \hline \text{D10} \\ \hline 0x00 \\ \hline \end{array}
 +
 \begin{array}{|c|} \hline \text{D11} \\ \hline 0x40 \\ \hline \end{array}
 =
 0x034F$$

CD0 = 0x4F, CD1 = 0x03

Packet to send

SFD	LEN	AD1	AD2	CMD	CIB		DIG		UBV		UGV		OBV		OGV		CD0	CD1
0x05	0x0C	0x00	0x01	0x1C	0xB8	0x1E	0xC4	0x20	0x00	0x38	0x86	0x32	0x00	0x48	0x00	0x40	0x4F	0x03

Command/Response Table

1. Table of command/response code

No.		Packet name	Packet		
			SFD	LEN	CMD
1	Operation Mode	1 Inquire Operation Mode	0x05	0x00	0x00
		2 ACK Response.	0x02	0x02	0x00
		3 NAK Response.	0x02	0x02	0x80
		4 Set Operation Mode	0x05	0x02	0x00
		5 ACK Response.	0x02	0x02	0x00
		6 NAK Response.	0x02	0x02	0x80
2	Converter Status	1 Inquire Converter Status	0x05	0x00	0x01
		2 ACK Response.	0x02	0x04	0x01
		3 NAK Response.	0x02	0x02	0x81
3	CV Charging Parameter	1 Read CV Charging Parameter	0x05	0x00	0x18
		2 ACK Response.	0x02	0x04	0x18
		3 NAK Response.	0x02	0x02	0x98
		4 Write CV Charging Parameter	0x05	0x04	0x18
		5 ACK Response.	0x02	0x04	0x18
		6 NAK Response.	0x02	0x02	0x98
4	CV Discharging Parameter	1 Read CV Discharging Parameter	0x05	0x00	0x1A
		2 ACK Response.	0x02	0x04	0x1A
		3 NAK Response.	0x02	0x02	0x9A
		4 Write CV Discharging Parameter	0x05	0x04	0x1A
		5 ACK Response.	0x02	0x04	0x1A
		6 NAK Response.	0x02	0x02	0x9A
5	Dead Zone Parameter	1 Read Dead Zone Parameter	0x05	0x00	0x17
		2 ACK Response.	0x02	0x04	0x17
		3 NAK Response.	0x02	0x02	0x97
		4 Write Dead Zone Parameter	0x05	0x04	0x17
		5 ACK Response.	0x02	0x04	0x17
		6 NAK Response.	0x02	0x02	0x97
6	Converter Protection Parameter	1 Read Converter Protection Parameter	0x05	0x00	0x1C
		2 ACK Response.	0x02	0x0C	0x1C
		3 NAK Response.	0x02	0x02	0x9C
		4 Write Converter Protection Parameter	0x05	0x0C	0x1C
		5 ACK Response.	0x02	0x0C	0x1C
		6 NAK Response.	0x02	0x02	0x9C
7	Battery Configuration Parameter1	1 Read Battery Configuration Parameter1	0x05	0x00	0x1D
		2 ACK Response.	0x02	0x0A	0x1D
		3 NAK Response.	0x02	0x02	0x9D
		4 Write Battery Configuration Parameter1	0x05	0x0A	0x1D
		5 ACK Response.	0x02	0x0A	0x1D
		6 NAK Response.	0x02	0x02	0x9D
8	Battery Configuration Parameter2	1 Read Battery Configuration Parameter2	0x05	0x00	0x16
		2 ACK Response.	0x02	0x04	0x16
		3 NAK Response.	0x02	0x02	0x96
		4 Write Battery Configuration Parameter2	0x05	0x04	0x16
		5 ACK Response.	0x02	0x04	0x16
		6 NAK Response.	0x02	0x02	0x96
9	Alarm	1 Inquire Alarm	0x05	0x00	0x12
		2 ACK Response.	0x02	0x06	0x12
		3 NAK Response.	0x02	0x02	0x92
		4 Clear Alarm	0x05	0x02	0x12
		5 ACK Response.	0x02	0x02	0x12
		6 NAK Response.	0x02	0x02	0x92

10	Converter Meter1	1	Read Converter Meter1	0x05	0x00	0x09
		2	ACK Response.	0x02	0x10	0x09
		3	NAK Response.	0x02	0x02	0x89
11	Converter Meter2	1	Read Converter Meter2	0x05	0x00	0x0A
		2	ACK Response.	0x02	0x10	0x0A
		3	NAK Response.	0x02	0x02	0x8A
12	Converter Meter1 Format	1	Read Converter Meter1 Format	0x05	0x00	0x0D
		2	ACK Response.	0x02	0x10	0x0D
		3	NAK Response.	0x02	0x02	0x8D
13	Converter Meter2 Format	1	Read Converter Meter2 Format	0x05	0x00	0x0E
		2	ACK Response.	0x02	0x10	0x0E
		3	NAK Response.	0x02	0x02	0x8E
14	Nominal Value	1	Read Nominal Value	0x05	0x00	0x11
		2	ACK Response.	0x02	0x14	0x11
		3	NAK Response.	0x02	0x02	0x91
15	Interface Firmware Version	1	Read Interface Firmware Version	0x05	0x00	0x1E
		2	ACK Response.	0x02	0x02	0x1E
		3	NAK Response.	0x02	0x02	0x9E
16	Control Firmware Version	1	Read Control Firmware Version	0x05	0x00	0x1F
		2	ACK Response.	0x02	0x02	0x1F
		3	NAK Response.	0x02	0x02	0x9F

2. Table of communication error code

Error code		Description	Trouble handling method
-1	0xFFFF	Received command is not supported	Please confirm the command.
-2	0xFFFE	Parameter is wrong (not fit number or out of range)	Please confirm the command parameter.
-3	0xFFFD	Can not receive accurate command	Please increase the length of communication intervals.
-4	0xFFFC	Can not send response because system is busy	Please increase the length of communication intervals.
-5	0xFFFB	Abnormal communication with internal device	Repair is necessary.

*When packet is wrong, there is no response.

This device can connect with plural same devices.

Which device receive command is selected by address setting.

When packet is wrong, device can not send response, because which device receive the command can be not identified.

Setting parameter table

1. Setting parameter table about operation mode

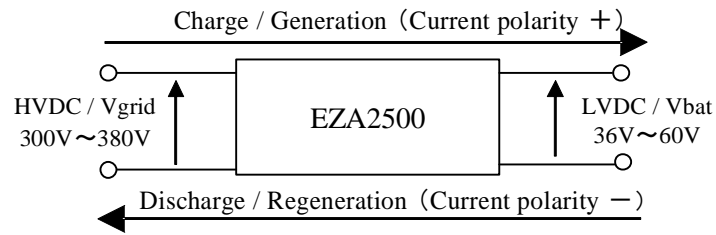

Block Diagram

■ Automatic Battery CV Mode

Name	Meaning	Command No.
CVB	Target Battery Volts	3
DRB	Droop Ratio of Battery	3
CIB	Current Limit of Battery	6
OBV	Over Battery Volts	6
UBV	Under Battery Volts	6
OGV	Over Grid Volts	6
UGV	Under Grid Volts	6
BCF	Battery Configure Function *1	7

*1 Active battery rampup function only.

■ Automatic Grid CV Mode

Name	Meaning	Command No.
DVG	Target Grid Volts	4
DRG	Droop Ratio of Grid	4
PDZ	Plus side volts for Dead Zone	5
MDZ	Minus side volts for Dead Zone	5
DIG	Current Limit of Grid	6
OGV	Over Grid Volts	6
UGV	Under Grid Volts	6
CIB	Current Limit of Battery *2	6
OBV	Over Battery Volts	6
UBV	Under Battery Volts	6
BCF	Battery Configure Function	7
CVB	Target Battery Volts (Voltage of Battery Upper Limit for Charging)	3, 7
CDB	Deviation of Volts for Warning of Charging Upper Limit	7
CCR	Deviation of Volts for Cancel Warning of Charging Upper Limit	8
DLB	Limit of Battery Volts for Discharging	7
DDB	Deviation of Volts for Warning of Discharging Lower Limit	7
DDR	Deviation of Volts for Cancel Warning of Discharging Lower Limit	8

*2 Active Automatic Grid CV with Battery CC Mode only.

■ **Manual CV Mode**

Name	Meaning	Command No.
CVB	Target Battery Volts (Voltage of Battery Upper Limit for Charging)	3, 7
DRB	Droop Ratio of Battery	3
CIB	Current Limit of Battery *3	6
OBV	Over Battery Volts	6
UBV	Under Battery Volts	6
DVG	Target Grid Volts	4
DRG	Droop Ratio of Grid	4
DIG	Limit Grid Amps	6
OGV	Over Grid Volts	6
UGV	Under Grid Volts	6
BCF	Battery Configure Function	7
CDB	Deviation of Volts for Warning of Charging Upper Limit	7
CCR	Deviation of Volts for Cancel Warning of Charging Upper Limit	8
DLB	Limit of Battery Volts for Discharging	7
DDB	Deviation of Volts for Warning of Discharging Lower Limit	7
DDR	Deviation of Volts for Cancel Warning of Discharging Lower Limit	8

*3 Active Manual Grid CV with Battery CC Mode only.

* CVB in command No3 "Write CV Charging Parameter Command" and CVB in command No7 "Write Converter Configuration Parameter1 Command" is same parameter write it in either. If both command are used, setting value is last command's.

2.Setting parameter table

Name	Meaning	Function	Data format	Q
CVB	Target Battery Volts	Set target of battery voltage for Battery CV mode. Format of this parameter is normalized Q14 format (rated value is 48V). If the Battery Over Charging Protection is enable, the parameter is used for limit of battery voltage for charging.	Normalized data	14
DRB	Droop Ratio of Battery	Set droop ratio of battery for balance of current in parallel operation. Droop ratio is percentage of drop voltage with nominal voltage when nominal current of battery flow. Format of this parameter is normalized Q13 format. ex) if you want to set droop ratio is 2%, write Drop ratio is 0.02 in Q13 format.	Normalized data	13
DVG	Target Grid Volts	Set target of grid voltage for Grid CV Mode. Format of this parameter is normalized Q14 format (nominal value is 380V).	Normalized data	14
DRG	Droop Ratio of Grid	Set droop ratio of grid for balance of current in parallel operation. Droop ratio is percentage of drop voltage with nominal voltage when nominal current of grid flow. Format of this parameter is normalized Q13 format. ex) if you want to set droop ratio is 2%, write Drop ratio is 0.02 in Q13 format.	Normalized data	13
CIB	Current Limit of Battery	Set upper limit current (CC) of battery. Format of this parameter is normalized Q13 format (nominal value is 52.08A). Setting is used bidirectional.	Normalized data	13
DIG	Current Limit of Grid	Set upper limit current (CC) of grid. Format of this parameter is normalized Q13 format (nominal value is 7.8125A). Setting is used bidirectional.	Normalized data	13
OBV	Over Battery Volts	Set threshold value of over voltage protection for battery. Format of this parameter is normalized Q14 format (nominal value is 48V). If battery voltage is over the threshold value, Output is stopped and alarm bit is set to high.	Normalized data	14
UBV	Under Battery Volts	Set threshold value of under voltage protection for battery. Format of this parameter is normalized Q14 format (rated value is 48V). If battery voltage is under the threshold value, Output is stopped and alarm bit is set to high.	Normalized data	14
OGV	Over Grid Volts	Set threshold value of over voltage protection for grid. Format of this parameter is normalized Q14 format (nominal value is 380V). If grid voltage is over the threshold value, Output is stopped and alarm bit is set to high.	Normalized data	14
UGV	Under Grid Volts	Set threshold value of under voltage protection for grid. Format of this parameter is normalized Q14 format nominal value is 380V). If grid voltage is under the threshold value, Output is stopped and alarm bit is set to high.	Normalized data	14

BCF	Battery Configure Function	<p>Enable or disable following functions.</p> <ul style="list-style-type: none"> • Battery over charging protection This function will strict the current for avoid over-charge when battery voltage reach to the setting value. (The converter can output discharging current to upper limit setting value.) • Battery over discharging protection This function will strict the current for avoid over-discharge when battery voltage reach to the setting value. (The converter can output charging current to upper limit setting value.) • Battery rump up This function forces the converter to charge the battery even in that the battery voltage is lower than Battery Under Voltage. 	Bitmap data	-
CDB	Deviation of Volts for Warning of Charging Upper Limit	<p>Set deviation of voltage for warning of charging upper limit. Set by deviation between CVB and voltage for warning of charging upper lim in normalized Q14 format (nominal value is 48V). ex) case CVB=48V and advance notice voltage = 46V, set deviation is 2V.</p>	Normalized data	14
CCR	Deviation of Volts for Cancel Warning of Charging Upper Limit	<p>Set deviation of voltage for cancel warning of charging upper limit. Set by deviation between CDB and voltage for cancel warning of charging upper lim in normalized Q13 format (nominal value is 48V). ex) case CDB =46V and voltage for cancel warning of charging upper lim = 45V, set deviation is 1V.</p>	Normalized data	14
DLB	Limit of Battery Volts for Discharging	<p>Set the limit of battery voltage for discharging. This parameter is used for Battery Over-Discharging Protection. Format of this parameter is normalized Q14 format (nominal value is 48V). Please set this parameter higher than UBV.</p>	Normalized data	14
DDB	Deviation of Volts for Warning of Discharging Lower Limit	<p>Set deviation of voltage for warning of discharging lower limit. Set by deviation between DLB and voltage for warning of charging upper lim in normalized Q14 format (nominal value is 48V) ex) case DLB=39V and voltage for warning of discharging lower limit = 42V, set deviation is 3V.</p>	Normalized data	14
DDR	Deviation of Volts for Cancel Warning of Discharging Lower Limit	<p>Set deviation of voltage for cancel warning of discharging lower limit. Set by deviation between DDB and voltage for cancel warning of charging upper lim in normalized Q14 format (nominal value is 48V). ex) case DDB = 42V and voltage for cancel warning of discharging lower limit = 44V, set deviation is 2V.</p>	Normalized data	14
PDZ	Plus side volts for Dead Zone	<p>Set plus side volts for dead zone. Format of this parameter is normalized Q14 format (nominal value is 380V). ex) If set upper side dead zone voltage +3.8V, set parameter is converted from 3.8/380 [0.01] in Q14 format.</p>	Normalized data	14
MDZ	Minus side volts for Dead Zone	<p>Set minus side volts for dead zone. Format of this parameter is normalized Q14 format (nominal value is 380V). ex) If set lower side dead zone voltage -3.8V, set parameter is converted from 3.8/380 [0.01] in Q14 format.</p>	Normalized data	14

Command reference

No 1-1 **Function Name** Inquire Operation Mode Command **R/W**: Read

Function

Inquire the converter operation mode.

CMD packet structure

SFD	LEN	AD1	AD2	CMD	CD0	CD1
0x05	0x00	rcvr	sndr	0x00	xx	xx

RSP packet structure

ACK

SFD	LEN	AD1	AD2	CMD	MODE		CD0	CD1
					D0	D1		
0x02	0x02	rcvr	sndr	0x00	data0	data1	xx	xx

NAK

SFD	LEN	AD1	AD2	CMD	D0	D1	CD0	CD1
0x02	0x02	rcvr	sndr	0x80	ERCD		xx	xx

CMD explanation

Request response of the converter operation mode.

RSP explanation

Response following operation mode.

Operation command	MODE	
	D0	D1
Waiting	0x00	0x00
Manual Battery CV	0x01	0x00
Manual Grid CV with Battery CC	0x22	0x00
Manual Grid CV	0x02	0x00
Automatic Battery CV	0x04	0x00
Automatic Grid CV with Battery CC	0x34	0x00
Automatic Grid CV	0x14	0x00

No 1-4 **Function Name** Set Operation Mode Command

R/W: Write

Function

Change the converter operation mode.

If alarm occurring, the converter do not accept the operation command.

CMD packet structure

					MODE			
SFD	LEN	AD1	AD2	CMD	D0	D1	CD0	CD1
0x05	0x02	rcvr	sndr	0x00	data0	data1	xx	xx

RSP packet structure

ACK

					MODE			
SFD	LEN	AD1	AD2	CMD	D0	D1	CD0	CD1
0x02	0x02	rcvr	sndr	0x00	data0	data1	xx	xx

NAK

SFD	LEN	AD1	AD2	CMD	D0	D1	CD0	CD1
0x02	0x02	rcvr	sndr	0x80	ERCD		xx	xx

CMD explanation

Set following operation mode.

Operation command	MODE	
	D0	D1
Waiting	0x00	0x00
Manual Battery CV	0x01	0x00
Manual Grid CV with Battery CC	0x22	0x00
Manual Grid CV	0x02	0x00
Automatic Battery CV	0x04	0x00
Automatic Grid CV with Battery CC	0x34	0x00
Automatic Grid CV	0x14	0x00

RSP explanation

Response the echo of operation command.

Operation command	MODE	
	D0	D1
Waiting	0x00	0x00
Manual Battery CV	0x01	0x00
Manual Grid CV with Battery CC	0x22	0x00
Manual Grid CV	0x02	0x00
Automatic Battery CV	0x04	0x00
Automatic Grid CV with Battery CC	0x34	0x00
Automatic Grid CV	0x14	0x00

No 2-1 **Function Name** Inquire Converter Status Command **R/W**: Read

Function

Inquire the converter status.

CMD packet structure

SFD	LEN	AD1	AD2	CMD	CD0	CD1
0x05	0x00	rcvr	sndr	0x01	xx	xx

RSP packet structure

ACK

					CST		EXT			
SFD	LEN	AD1	AD2	CMD	D0	D1	D2	D3	CD0	CD1
0x02	0x04	rcvr	sndr	0x01	data0	data1	data2	data3	xx	xx

NAK

SFD	LEN	AD1	AD2	CMD	D0	D1	CD0	CD1
0x02	0x02	rcvr	sndr	0x81	ERCD		xx	xx

CMD explanation

Request response of running state, alarm state and operation mode.

RSP explanation

Response bitmap table for CST (Converter status).

D	bit	Name	Function
D0	0	Running state	0 : Off, 1 : Charge, 2 : Discharge
	1		
	2	Alarm state	0 : No Alarm, 1: Light Alarm, 2: Heavy Alarm
	3		
	4	Operation mode	0:Waiting, 1:Manual CV, 3:Automatic Grid CV, 4:Automatic Battery CV
	5		
	6		
	7	(Reserved)	
	8	(Reserved)	
D1	9	Advance notice of upper limit of battery voltage for charge	1 : upper than advance notice voltage 0 : lower than advance notice voltage
	10	Advance notice of lower limit of battery voltage for charge	1 : lower than advance notice voltage 0 : upper than advance notice voltage
	11	(Reserved)	
	12	(Reserved)	
	13	(Reserved)	
	14	(Reserved)	
	15	(Reserved)	

Attention) EXT (extended converter status) is reserved.

ex) case CST=0x4102

D0 = 0x41 : (D0 is bit 0-7)

If D0 is 0x41, it means 01000001 in binary.

It is bit0 and bit6 is set. So running state is charge,

alarm state is No Alarm and operation mode is Automatic Battery CV.

D1 = 0x02 : (D1 is bit 8-15)

If D1 is 0x02, it means 00000010 in binary.

So Battery voltage is upper than advance notice voltage of upper limit for charge and upper than advance notice voltage of lower limit for discharge.

No 3-1 **Function Name** Read CV Charging Parameter Command **R/W**: Read

Function

Read parameter about CV charge.

CMD packet structure

SFD	LEN	AD1	AD2	CMD	CD0	CD1
0x05	0x00	rcvr	sndr	0x18	xx	xx

RSP packet structure

ACK

					CVB		DRB			
SFD	LEN	AD1	AD2	CMD	D0	D1	D2	D3	CD0	CD1
0x02	0x04	rcvr	sndr	0x18	data0	data1	data2	data3	xx	xx

NAK

SFD	LEN	AD1	AD2	CMD	D0	D1	CD0	CD1
0x02	0x02	rcvr	sndr	0x98	ERCD		xx	xx

Data table

Name	Meaning	Format	Q	Minimum	Maximum
CVB	Target Battery Volts	Normalized data	14	32/48	62/48
DRB	Droop Ratio of Battery	Normalized data	13	0/1.000	3.999/1.000

CMD explanation

Request response about setting parameter.

RSP explanation

ACK

Return parameter.

NAK

Return error code (ERCD).

*About droop rate

If droop rate is 2%, return parameter is converted from [0.02] in Q13 format.

No 3-4 **Function Name** Write CV Charging Parameter Command R/W: Write

Function

Write parameter about CV charge.

CMD packet structure

					CVB		DRB			
SFD	LEN	AD1	AD2	CMD	D0	D1	D2	D3	CD0	CD1
0x05	0x04	rcvr	sndr	0x18	data0	data1	data2	data3	xx	xx

RSP packet structure

ACK

					CVB		DRB			
SFD	LEN	AD1	AD2	CMD	D0	D1	D2	D3	CD0	CD1
0x02	0x04	rcvr	sndr	0x18	data0	data1	data2	data3	xx	xx

NAK

SFD	LEN	AD1	AD2	CMD	D0	D1	CD0	CD1
0x02	0x02	rcvr	sndr	0x98	ERCD		xx	xx

Data table

Name	Meaning	Format	Q	Minimum	Maximum
CVB	Target Battery Volts	Normalized data	14	32/48	62/48
DRB	Droop Ratio of Battery	Normalized data	13	0/1.000	3.999/1.000

CMD explanation

Set parameter.

RSP explanation

ACK

Return echo of sent command.

NAK

Return error code (ERCD).

*About droop rate

If set droop rate 2%, set parameter is converted from [0.02] in Q13 format.

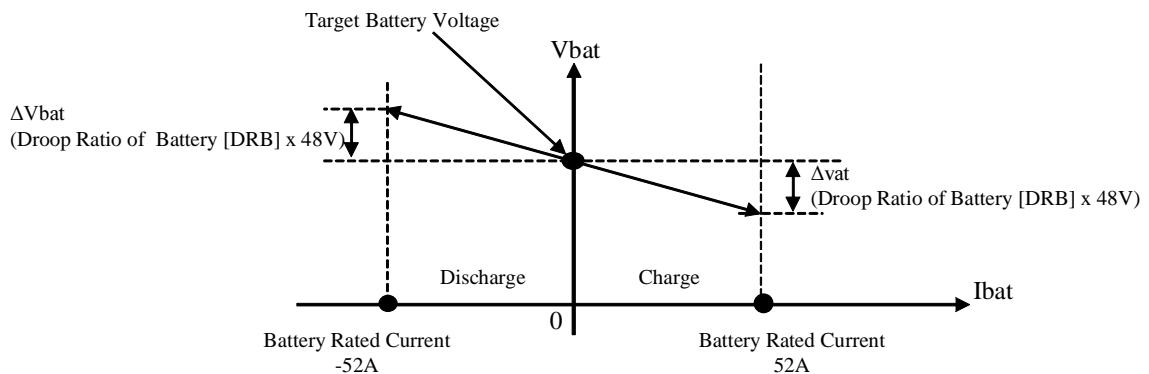

Definition of Droop Ratio

No 4-1 **Function Name** Read CV Discharging Parameter Command **R/W**: Read

Function

Read parameter about CV discharge.

CMD packet structure

SFD	LEN	AD1	AD2	CMD	CD0	CD1
0x05	0x00	rcvr	sndr	0x1A	xx	xx

RSP packet structure

ACK

					DVG		DRG			
SFD	LEN	AD1	AD2	CMD	D0	D1	D2	D3	CD0	CD1
0x02	0x04	rcvr	sndr	0x1A	data0	data1	data2	data3	xx	xx

NAK

SFD	LEN	AD1	AD2	CMD	D0	D1	CD0	CD1
0x02	0x02	rcvr	sndr	0x9A	ERCD		xx	xx

Data table

Name	Meaning	Format	Q	Minimum	Maximum
DVG	Target Grid Volts	Normalized data	14	260/380	390/380
DRG	Droop Ratio of Grid	Normalized data	13	0/1.000	3.999/1.000

CMD explanation

Request response about setting parameter.

RSP explanation

ACK

Return parameter.

NAK

Return error code (ERCD).

*About droop rate

If droop rate is 2%, return parameter is converted from [0.02] in Q13 format.

No 4-4 **Function Name** Write CV Discharging Parameter Command **R/W**: Write

Function

Write parameter about CV discharge.

CMD packet structure

					DVG		DRG			
SFD	LEN	AD1	AD2	CMD	D0	D1	D2	D3	CD0	CD1
0x05	0x04	rcvr	sndr	0x1A	data0	data1	data2	data3	xx	xx

RSP packet structure

ACK

					DVG		DRG			
SFD	LEN	AD1	AD2	CMD	D0	D1	D2	D3	CD0	CD1
0x02	0x04	rcvr	sndr	0x1A	data0	data1	data2	data3	xx	xx

NAK

SFD	LEN	AD1	AD2	CMD	D0	D1	CD0	CD1
0x02	0x02	rcvr	sndr	0x9A	ERCD		xx	xx

Data table

Name	Meaning	Format	Q	Minimum	Maximum
DVG	Target Grid Volts	Normalized data	14	260/380	390/380
DRG	Droop Ratio of Grid	Normalized data	13	0/1.000	3.999/1.000

CMD explanation

Set parameter.

RSP explanation

ACK

Return echo of sent command.

NAK

Return error code (ERCD).

*About droop rate

If set droop rate 2%, set parameter is converted from [0.02] in Q13 format.

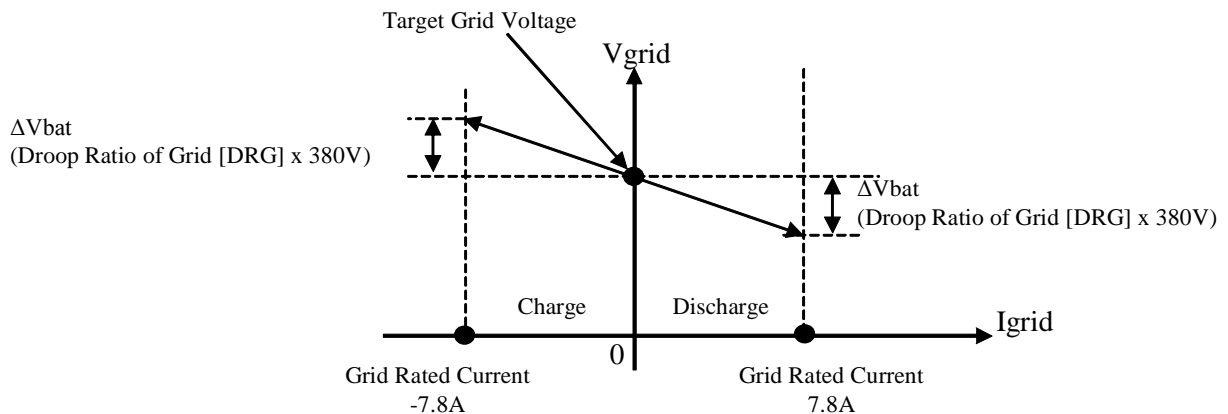

Definition of Droop Ratio

No 5-1 **Function Name** Read Dead Zone Parameter Command **R/W**: Read

Function

Read parameter about dead zone.

CMD packet structure

SFD	LEN	AD1	AD2	CMD	CD0	CD1
0x05	0x00	rcvr	sndr	0x17	xx	xx

RSP packet structure

ACK

					PDZ		MDZ			
SFD	LEN	AD1	AD2	CMD	D0	D1	D2	D3	CD0	CD1
0x02	0x04	rcvr	sndr	0x17	data0	data1	data2	data3	xx	xx

NAK

SFD	LEN	AD1	AD2	CMD	D0	D1	CD0	CD1
0x02	0x02	rcvr	sndr	0x97	ERCD		xx	xx

Data table

Name	Meaning	Format	Q	Minimum	Maximum
PDZ	Plus side volts for dead zone	Normalized data	14	0/380	57/380
MDZ	Minus side volts for dead zone	Normalized data	14	0/380	57/380

CMD explanation

Request response about setting parameter.

RSP explanation

ACK

Return parameter.

NAK

Return error code (ERCD).

*About dead zone voltage

If dead zone voltage is $\pm 3.8V$, return parameter is converted from 3.8/380 [0.01] in Q14 format.

No 5-4 **Function Name** Write Dead Zone Parameter Command **R/W**: Write

Function

Write parameter about dead zone.

CMD packet structure

SFD	LEN	AD1	AD2	CMD	PDZ		MDZ			
0x05	0x04	rcvr	sndr	0x17	data0	data1	data2	data3	xx	xx

RSP packet structure

ACK

SFD	LEN	AD1	AD2	CMD	PDZ		MDZ			
0x02	0x04	rcvr	sndr	0x17	data0	data1	data2	data3	xx	xx

NAK

SFD	LEN	AD1	AD2	CMD	D0	D1	CD0	CD1
0x02	0x02	rcvr	sndr	0x97	ERCD		xx	xx

Data table

Name	Meaning	Format	Q	Minimum	Maximum
PDZ	Plus side volts for dead zone	Normalized data	14	0/380	57/380
MDZ	Minus side volts for dead zone	Normalized data	14	0/380	57/380

CMD explanation

Set parameter.

RSP explanation

ACK

Return echo of sent command.

NAK

Return error code (ERCD).

*About dead zone voltage

If set dead zone voltage $\pm 3.8V$, set parameter is converted from 3.8/380 [0.01] in Q14 format.

No 6-1 **Function Name** Read Converter Protection Parameter Command **R/W**: Read

Function

Read parameter about protection.

CMD packet structure

SFD	LEN	AD1	AD2	CMD	CD0	CD1
0x05	0x00	rcvr	sndr	0x1C	xx	xx

RSP packet structure

ACK

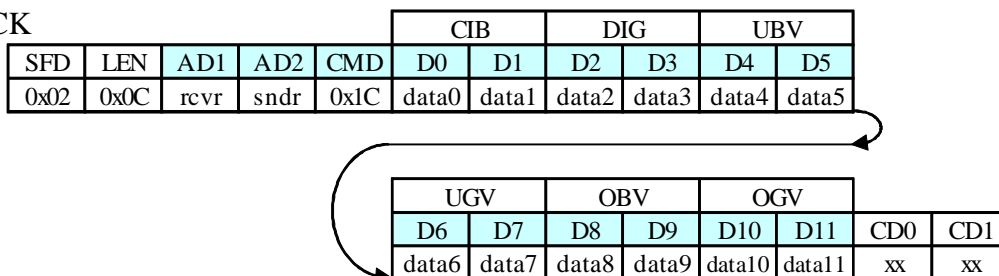

NAK

SFD	LEN	AD1	AD2	CMD	D0	D1	CD0	CD1
0x02	0x02	rcvr	sndr	0x9C	ERCD		xx	xx

Data table

Name	Meaning	Format	Q	Minimum	Maximum
CIB	Current Limit of Battery	Normalized data	13	0/52.08	56.77/52.08
DIG	Current Limit of Grid	Normalized data	13	0/7.8125	8.5162/7.8125
UBV	Under Battery Volts	Normalized data	14	32/48	68/48
UGV	Under Grid Volts	Normalized data	14	260/380	410/380
OBV	Over Battery Volts	Normalized data	14	32/48	68/48
OGV	Over Grid Volts	Normalized data	14	260/380	410/380

CMD explanation

Request response about setting parameter.

RSP explanation

ACK

Return parameter.

NAK

Return error code (ERCD).

No 6-4 **Function Name** Write Converter Protection Parameter Command **R/W**: Write

Function

Write parameter about protection.

CMD packet structure

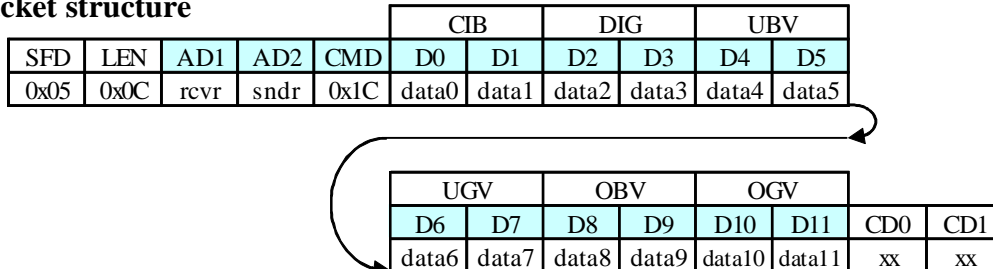

RSP packet structure

ACK

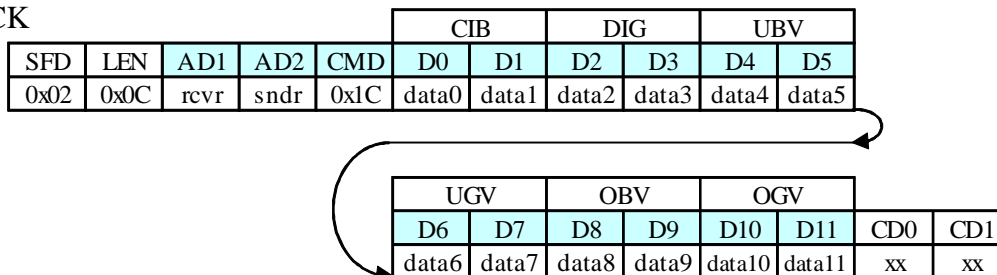

NAK

SFD	LEN	AD1	AD2	CMD	D0	D1	CD0	CD1
0x02	0x02	rcvr	sndr	0x9C	ERCD	xx	xx	

Data table

Name	Meaning	Format	Q	Minimum	Maximum
CIB	Current Limit of Battery	Normalized data	13	0/52.08	56.77/52.08
DIG	Current Limit of Grid	Normalized data	13	0/7.8125	8.5162/7.8125
UBV	Under Battery Volts	Normalized data	14	32/48	68/48
UGV	Under Grid Volts	Normalized data	14	260/380	410/380
OBV	Over Battery Volts	Normalized data	14	32/48	68/48
OGV	Over Grid Volts	Normalized data	14	260/380	410/380

CMD explanation

Set parameter.

RSP explanation

ACK

Return echo of sent command.

NAK

Return error code (ERCD).

No 7-1 **Function Name** Read Battery Configuration Parameter1 Command **R/W**: Read

Function

Read battery configuration1.

CMD packet structure

SFD	LEN	AD1	AD2	CMD	CD0	CD1
0x05	0x00	rcvr	sndr	0x1D	xx	xx

RSP packet structure

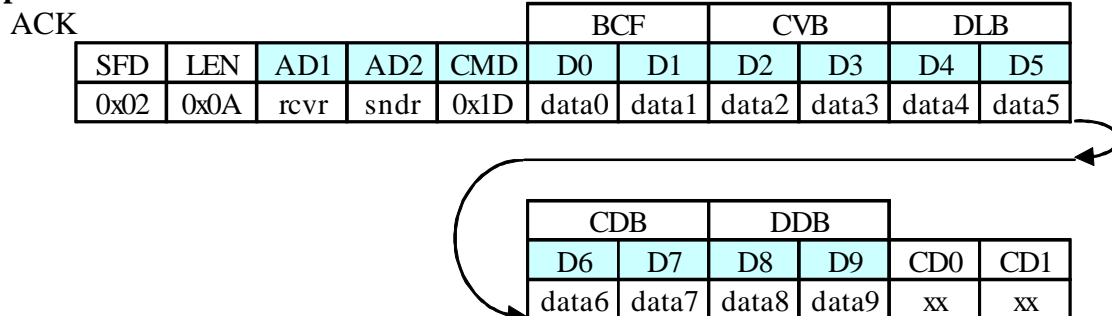

NAK

SFD	LEN	AD1	AD2	CMD	D0	D1	CD0	CD1
0x02	0x02	rcvr	sndr	0x9D	ERCD		xx	xx

Data table

Name	Meaning	Format	Q	Minimum	Maximum
BCF	Battery Configure Function	Bitmap data	0	-	-
CVB	Target Battery Volts	Normalized data	14	32/48	62/48
DLB	Limit of Battery Volts for Discharging	Normalized data	14	32/48	64/48
CDB	Deviation of Volts for Warning of Charging Upper Limit	Normalized data	14	0/48	12/48
DDB	Deviation of Volts for Warning of Discharging Lower Limit	Normalized data	14	0/48	12/48

Refer "BCF parameter" page about BCF

CMD explanation

Request response about setting parameter.

RSP explanation

ACK

Return parameter.

NAK

Return error code (ERCD).

No 7-4 **Function Name** Write Battery Configuration Parameter1 Command R/W : Write

Function

Write battery configuration.

CMD packet structure

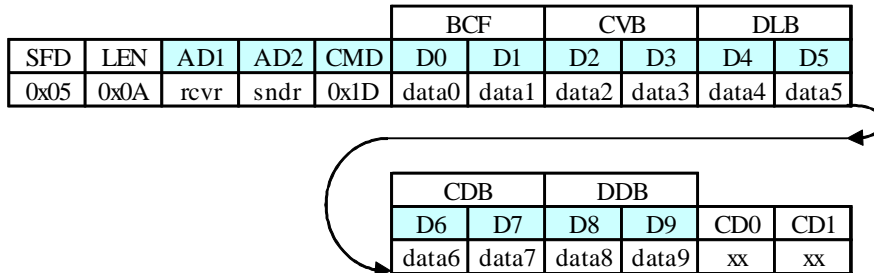

RSP packet structure

ACK

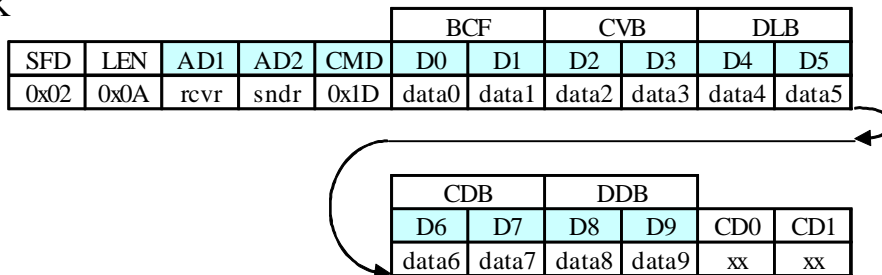

NAK

SFD	LEN	AD1	AD2	CMD	D0	D1	CD0	CD1
0x02	0x02	rcvr	sndr	0x9D	ERCD		xx	xx

Data table

Name	Meaning	Format	Q	Minimum	Maximum
BCF	Battery Configure Function	Bitmap data	0	-	-
CVB	Target Battery Volts	Normalized data	14	32/48	62/48
DLB	Limit of Battery Volts for Discharging	Normalized data	14	32/48	64/48
CDB	Deviation of Volts for Warning of Charging Upper Limit	Normalized data	14	0/48	12/48
DDB	Deviation of Volts for Warning of Discharging Lower Limit	Normalized data	14	0/48	12/48

Refer "BCF parameter" page about BCF

CMD explanation

Set parameter.

RSP explanation

ACK

Return echo of sent command.

NAK

Return error code (ERCD).

No 8-1 **Function Name** Read Battery Configuration Parameter2 Command **R/W**: Read

Function

Read battery configuration2.

CMD packet structure

SFD	LEN	AD1	AD2	CMD	CD0	CD1
0x05	0x00	rcvr	sndr	0x16	xx	xx

RSP packet structure

ACK

					CCR		DDR			
SFD	LEN	AD1	AD2	CMD	D0	D1	D2	D3	CD0	CD1
0x02	0x04	rcvr	sndr	0x16	data0	data1	data2	data3	xx	xx

NAK

SFD	LEN	AD1	AD2	CMD	D0	D1	CD0	CD1
0x02	0x02	rcvr	sndr	0x96	ERCD		xx	xx

Data table

Name	Meaning	Format	O	Minimum	Maximum
CCR	Deviation of Volts for Cancel Warning of Charging Upper Limit	Normalized data	14	0/48	12/48
DDR	Deviation of Volts for Cancel Warning of Discharging Lower Limit	Normalized data	14	0/48	12/48

Voltage for release warning of charging upper limit is (CVB - CDB - CCR).

Voltage for release warning of discharging lower limit is (DLB + DDB + DDR).

CMD explanation

Request response about setting parameter.

RSP explanation

ACK

Return parameter.

NAK

Return error code (ERCD).

No 8-4 **Function Name** Write Battery Configuration Parameter2 Command **R/W**: Write

Function

Write battery configuration parameter2.

CMD packet structure

					CCR		DDR			
SFD	LEN	AD1	AD2	CMD	D0	D1	D2	D3	CD0	CD1
0x05	0x04	rcvr	sndr	0x16	data0	data1	data2	data3	xx	xx

RSP packet structure

ACK

					CCR		DDR			
SFD	LEN	AD1	AD2	CMD	D0	D1	D2	D3	CD0	CD1
0x02	0x04	rcvr	sndr	0x16	data0	data1	data2	data3	xx	xx

NAK

SFD	LEN	AD1	AD2	CMD	D0	D1	CD0	CD1
0x02	0x02	rcvr	sndr	0x96	ERCD		xx	xx

Data table

Name	Meaning	Format	Q	Minimum	Maximum
CCR	Deviation of Volts for Cancel Warning of Charging Upper Limit	Normalized data	14	0/48	12/48
DDR	Deviation of Volts for Cancel Warning of Discharging Lower Limit	Normalized data	14	0/48	12/48

Voltage for release warning of charging upper limit is (CVB - CDB - CCR).

Voltage for release warning of discharging lower limit is (DLB + DDB + DDR).

CMD explanation

Set parameter.

RSP explanation

ACK

Return echo of sent command.

NAK

Return error code (ERCD).

No 9-1 **Function Name** Inquire Alarm Command

R/W: Read

Function

Inquire alarm information.

CMD packet structure

SFD	LEN	AD1	AD2	CMD	CD0	CD1
0x05	0x00	rcvr	sndr	0x12	xx	xx

RSP packet structure

ACK

					ALM1		ALM2		ALM3			
SFD	LEN	AD1	AD2	CMD	D0	D1	D2	D3	D4	D5	CD0	CD1
0x02	0x06	rcvr	sndr	0x12	data0	data1	data2	data3	data4	data5	xx	xx

NAK

SFD	LEN	AD1	AD2	CMD	D0	D1	CD0	CD1
0x02	0x02	rcvr	sndr	0x92	ERCD		xx	xx

Data table

defined alarm bit(ALM1)

ALM	D	bit	ALM1		Meaning	Waiting	Manual CV		Automatic CV		
			D0	D1			Battery	Grid	Battery	Grid	
ALM1	D0	0	0x01	-	Battery Over Voltage	Light Alarm	Heavy Alarm	Light Alarm	Heavy Alarm	Light Alarm	
		1	0x02	-	Battery under Voltage	Light Alarm	Heavy Alarm	Heavy Alarm	Heavy Alarm	Heavy Alarm	
		2	0x04	-	Battery Over Current	Heavy Alarm	Heavy Alarm	Heavy Alarm	Heavy Alarm	Heavy Alarm	
		3	0x08	-	Grid Over Voltage	Light Alarm	Light Alarm	Heavy Alarm	Heavy Alarm	Heavy Alarm	
		4	0x10	-	Grid under Voltage	Light Alarm	Light Alarm	Heavy Alarm	Heavy Alarm	Heavy Alarm	
		5	0x20	-	Grid Over Current	Heavy Alarm	Heavy Alarm	Heavy Alarm	Heavy Alarm	Heavy Alarm	
		6	0x40	-	HW Over Current	-	Heavy Alarm	Heavy Alarm	Heavy Alarm	Heavy Alarm	
	7	0x80	-	Waiting (External Signal)	Heavy Alarm	Heavy Alarm	Heavy Alarm	Heavy Alarm	Heavy Alarm		
	D1	8	-	0x01	-	FAN Lock	-	Heavy Alarm	Heavy Alarm	Heavy Alarm	Heavy Alarm
		9	-	0x02	-	Abnormal Temp of Heat Sink (pri)	Heavy Alarm	Heavy Alarm	Heavy Alarm	Heavy Alarm	Heavy Alarm
		10	-	0x04	-	Abnormal Temp of Heat Sink (sec)	Heavy Alarm	Heavy Alarm	Heavy Alarm	Heavy Alarm	Heavy Alarm
		11	-	0x08	-	Abnormal Temp of Device	Light Alarm	Light Alarm	Light Alarm	Heavy Alarm	Light Alarm
		12	-	-	-	(Reserved)	-	-	-	-	-
		13	-	0x20	-	Battery Empty	Warning	Warning	Warning	Warning	Warning
		14	-	-	-	(Reserved)	-	-	-	-	-
15		-	0x80	-	System Abnormal	Heavy Alarm	Heavy Alarm	Heavy Alarm	Heavy Alarm	Heavy Alarm	

Bit15 of ALM1 is the calculation result that OR operation of all ALM3 bits.

CMD explanation

Request alarm information of this device.

RSP explanation

ACK

Return alarm information.

NAK

Return error code (ERCD).

No 9-4 **Function Name** Clear Alarm Command

R/W: Write

Function

Clear alarm.

CMD packet structure

SFD	LEN	AD1	AD2	CMD	D0	D1	CD0	CD1
0x05	0x02	rcvr	sndr	0x12	0x00	0x00	xx	xx

RSP packet structure

ACK

SFD	LEN	AD1	AD2	CMD	D0	D1	CD0	CD1
0x02	0x02	rcvr	sndr	0x12	0x00	0x00	xx	xx

NAK

SFD	LEN	AD1	AD2	CMD	D0	D1	CD0	CD1
0x02	0x02	rcvr	sndr	0x92	ERCD		xx	xx

CMD explanation

Clear alarm of device.

RSP explanation

ACK

Clear alarm.

Return echo of sent command.

NAK

Return error code (ERCD).

*If the device detects Hardware Over Voltage Alarm or Hardware Over Current Alarm when the alarm clear command received, the device return error code 0xFFFFD (-3) and do not clear alarm.

No 10-1 **Function Name** Read Converter Meter1 Command **R/W**: Read

Function

Read measurements 1 of sensor in this device.

CMD packet structure

SFD	LEN	AD1	AD2	CMD	CD0	CD1
0x05	0x00	rcvr	sndr	0x09	xx	xx

RSP packet structure

ACK

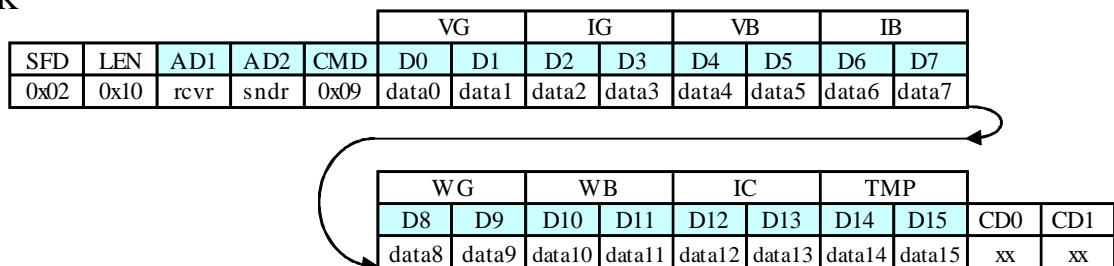

NAK

SFD	LEN	AD1	AD2	CMD	D0	D1	CD0	CD1
0x02	0x02	rcvr	sndr	0x89	ERCD		xx	xx

Data table

Name	Unit	Meaning	Value	Q
VG	[V]	Grid Voltage	Measurement/380	14
IG	[A]	Grid Current	Measurement/7.8125	13
VB	[V]	Battery Voltage	Measurement/48	14
IB	[A]	Battery Current	Measurement/52.08	13
WG	[W]	Grid Power	Measurement/2500	11
WB	[W]	Battery Power	Measurement/2500	11
IC	-	Reserved	---	-
TMP	[°C]	Converter Temperature	Measurement	7

CMD explanation

Request measurements.

RSP explanation

ACK

Return measurements of sensor in this device.

Response value is normal or normalized measurement in Q format. It is 16 bit width include sign.

NAK

Return error code (ERCD).

Attention)

"IC" is reserved. Return value is "0".

The polarities of current are generation is positive and regeneration is negative.

Reading voltage accuracy in specification is below range.

Battery voltage 32V - 68V, Grid Voltage : 260V - 410V

No 11-1 **Function Name** Read Converter Meter2 Command **R/W**: Read

Function

Read measurements 2 of sensor in this device.

CMD packet structure

SFD	LEN	AD1	AD2	CMD	CD0	CD1
0x05	0x00	rcvr	sndr	0x0A	xx	xx

RSP packet structure

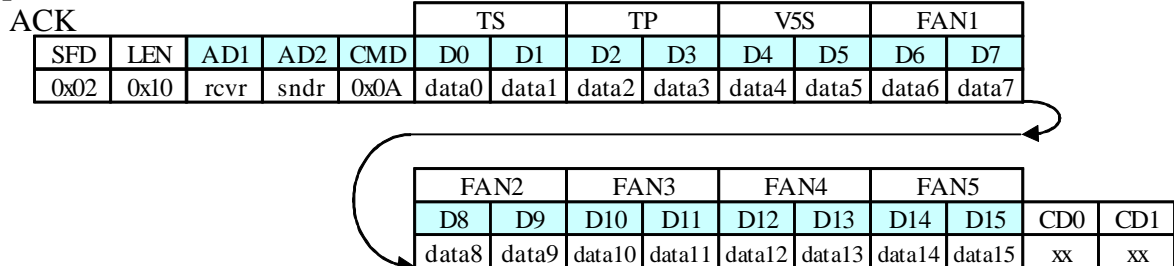

NAK

SFD	LEN	AD1	AD2	CMD	D0	D1	CD0	CD1
0x02	0x02	rcvr	sndr	0x8A	ERCD		xx	xx

Data table

Name	Unit	Meaning	Value	Q
TS	-	Reserved	---	-
TP	-	Reserved	---	-
V5S	[V]	5VS voltage	Measurement	10
FAN1	[rpm]	FAN1 revolution speed	Measurement	0
FAN2	[rpm]	FAN2 revolution speed	Measurement	0
FAN3	[rpm]	FAN3 revolution speed	Measurement	0
FAN4	[rpm]	FAN4 revolution speed	Measurement	0
FAN5	[rpm]	FAN5 revolution speed	Measurement	0

CMD explanation

Request measurements.

RSP explanation

ACK

Return measurements of sensor in this device.

Response value is normal measurement in Q format. It is 16 bit width include sign.

NAK

Return error code (ERCD).

Attention)

"TS" and "TP" are reserved.

No 12-1 **Function Name** Read Converter Meter1 Format Command **R/W**: Read

Function

Read format about measurements 1.

CMD packet structure

SFD	LEN	AD1	AD2	CMD	CD0	CD1
0x05	0x00	rcvr	sndr	0x0D	xx	xx

RSP packet structure

ACK

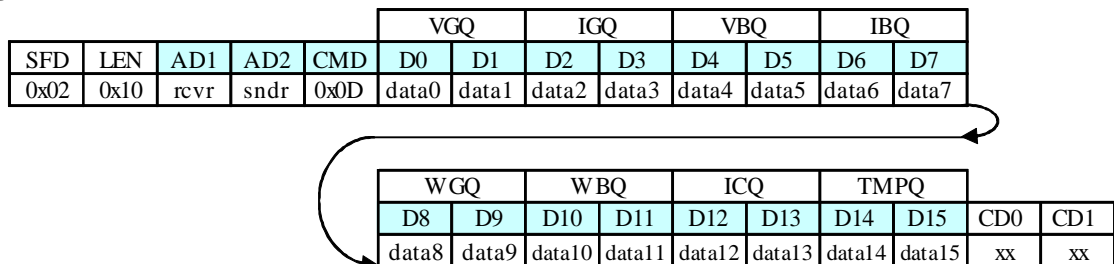

NAK

SFD	LEN	AD1	AD2	CMD	D0	D1	CD0	CD1
0x02	0x02	rcvr	sndr	0x8D	ERCD		xx	xx

Data table

Name	Meaning	Return	
VGQ	Q Value of Grid Voltage	14	(0x000E)
IGQ	Q Value of Grid Current	13	(0x000D)
VBQ	Q Value of Battery Voltage	14	(0x000E)
IBQ	Q Value of Battery Current	13	(0x000D)
WGQ	Q Value of Grid Power	11	(0x000B)
WBQ	Q Value of Battery Power	11	(0x000B)
ICQ	Reserved	-	---
TMPQ	Q Value of Converter Temperature	7	(0x0007)

CMD explanation

Request Q value for measurements.

RSP explanation

ACK

Return Q value for conversion of measurements.

This is read only. This can not be changed.

NAK

Return error code (ERCD).

No 13-1 **Function Name** Read Converter Meter2 Format Command **R/W**: Read

Function

Read format about measurements 2.

CMD packet structure

SFD	LEN	AD1	AD2	CMD	CD0	CD1
0x05	0x00	rcvr	sndr	0x0E	xx	xx

RSP packet structure

ACK

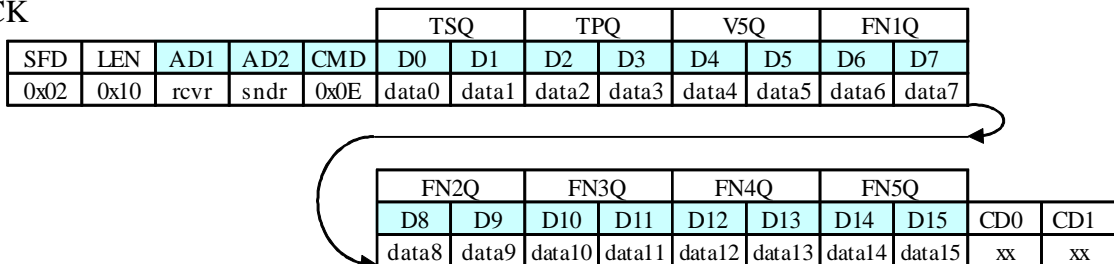

NAK

SFD	LEN	AD1	AD2	CMD	D0	D1	CD0	CD1
0x02	0x02	rcvr	sndr	0x8E	ERCD		xx	xx

Data table

Name	Meaning	Return	
TSQ	Reserved	-	---
TPQ	Reserved	-	---
V5Q	Q Value of 5VS Voltage	10	(0x000A)
FN1Q	Q Value of FAN1 Revolution Speed	0	(0x0000)
FN2Q	Q Value of FAN2 Revolution Speed	0	(0x0000)
FN3Q	Q Value of FAN3 Revolution Speed	0	(0x0000)
FN4Q	Q Value of FAN4 Revolution Speed	0	(0x0000)
FN5Q	Q Value of FAN5 Revolution Speed	0	(0x0000)

CMD explanation

Request Q value for measurements.

RSP explanation

ACK

Return Q value for conversion of measurements.

This is read only. This can not be changed.

NAK

Return error code (ERCD).

No 14-1 **Function Name** Read Nominal Value Command **R/W**: Read

Function

Read nominal value.

CMD packet structure

SFD	LEN	AD1	AD2	CMD	CD0	CD1
0x05	0x00	rcvr	sndr	0x11	xx	xx

RSP packet structure

ACK

					VGN		VGNQ		IGN		IGNQ		VBN	
SFD	LEN	AD1	AD2	CMD	D0	D1	D2	D3	D4	D5	D6	D7	D8	D9
0x02	0x14	rcvr	sndr	0x11	data0	data1	data2	data3	data4	data5	data6	data7	data8	data9

	VBNQ		IBN		IBNQ		WN		WNQ			
	D10	D11	D12	D13	D14	D15	D16	D17	D18	D19	CD0	CD1
	data10	data11	data12	data13	data14	data15	data16	data17	data18	data19	xx	xx

NAK

SFD	LEN	AD1	AD2	CMD	D0	D1	CD0	CD1
0x02	0x02	rcvr	sndr	0x91	ERCD		xx	xx

Data table

Name	Meaning	Value	Return (dec)	Return (hex)
VGN	Nominal Voltage of Grid	380	24320	0x5F00
VGNQ	Q Value for Nominal Value of Grid Voltage	6		0x0006
IGN	Nominal Current of Grid	7.8125	8000	0x1F40
IGNQ	Q Value for Nominal Value of Grid Current	10		0x000A
VBN	Nominal Voltage of Battery	48	12288	0x3000
VBNQ	Q Value for Nominal Value of Battery Voltage	8		0x0008
IBN	Nominal Current of Battery	52.083	13333	0x3415
IBNQ	Q Value for Nominal Value of Battery Current	8		0x0008
WN	Nominal Power	2500	2500	0x09C4
WNQ	Q Value for Nominal Value of Power	0		0x0000

CMD explanation

Request nominal value and Q value.

RSP explanation

ACK

Return normal nominal value in Q format and Q value.

This is read only. This can not be changed.

NAK

Return error code (ERCD).

Caution) Nominal value in this Document is standard value. It is not equal with rated value in electrical specification.

No 15-1 **Function Name** Read Interface Firmware Version Command **R/W**: Read

Function

Read version about interface firmware.

CMD packet structure

SFD	LEN	AD1	AD2	CMD	CD0	CD1
0x05	0x00	rcvr	sndr	0x1E	xx	xx

RSP packet structure

ACK

					Min	Maj		
SFD	LEN	AD1	AD2	CMD	D0	D1	CD0	CD1
0x02	0x02	rcvr	sndr	0x1E	data0	data1	xx	xx

NAK

SFD	LEN	AD1	AD2	CMD	D0	D1	CD0	CD1
0x02	0x02	rcvr	sndr	0x9E	ERCD		xx	xx

Data table

Name	Meaning	Format
Min	Number of Miner	Nominal data
Maj	Number of Major	Nominal data

CMD explanation

Request version about firmware.

RSP explanation

ACK

Return number of firmware's version.

NAK

Return error code (ERCD).

No 16-1 **Function Name** Read Control Firmware Version Command **R/W**: Read

Function

Read version about control firmware.

CMD packet structure

SFD	LEN	AD1	AD2	CMD	CD0	CD1
0x05	0x00	rcvr	sndr	0x1F	xx	xx

RSP packet structure

ACK

					Min	Maj		
SFD	LEN	AD1	AD2	CMD	D0	D1	CD0	CD1
0x02	0x02	rcvr	sndr	0x1F	data0	data1	xx	xx

NAK

SFD	LEN	AD1	AD2	CMD	D0	D1	CD0	CD1
0x02	0x02	rcvr	sndr	0x9F	ERCD		xx	xx

Data table

Name	Meaning	Format
Min	Number of Miner	Nominal data
Maj	Number of Major	Nominal data

CMD explanation

Request version about firmware.

RSP explanation

ACK

Return number of firmware's version.

NAK

Return error code (ERCD).

BCF Parameter

Functions for converter are controlled by BCF parameter in command 7-1 "Write Battery Configuration Parameter1 Command"

Bitmap table of BCF parameter

bit	Name	Function
0	Battery over charging protection.	0 : disable
		1 : enable
1	Battery over discharging protection.	0 : disable
		1 : enable
2	Battery bus ramping up.	0 : enable
		1 : disable
3~15	Reserved	reserved bit (set '0')

1.Function

•Battery over charging protection

This function will strict the current for avoid over-charge when battery voltage reach to the setting value.
(The converter can output discharging current to upper limit setting value.)

See below about relation of Limit of Battery Volts for Charging, Warning of Charging Upper Limit, Release Warning of Charging Upper Limit.

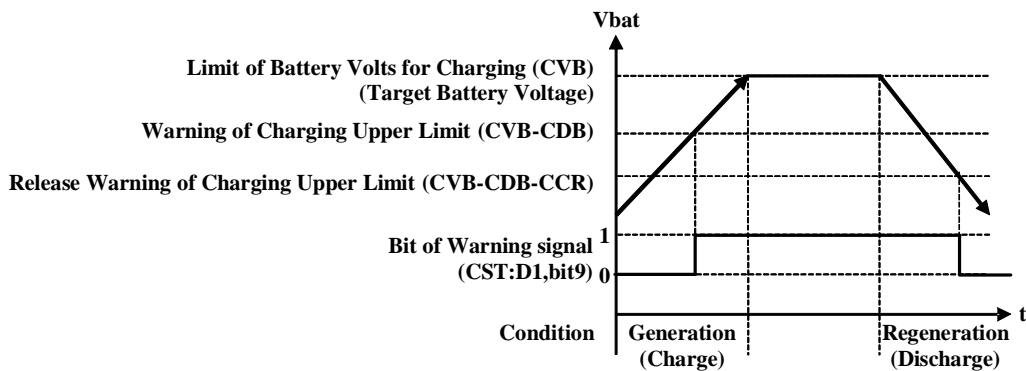

Battery Over Charging Protection Timing Chart

•Battery over discharging protection

This function will strict the current for avoid over-discharge when battery voltage reach to the setting value.
(The converter can output charging current to upper limit setting value.)

See below about relation of Limit of Battery Volts for Discharging, Warning of Discharging Upper Limit, Release Warning of Discharging Upper Limit.

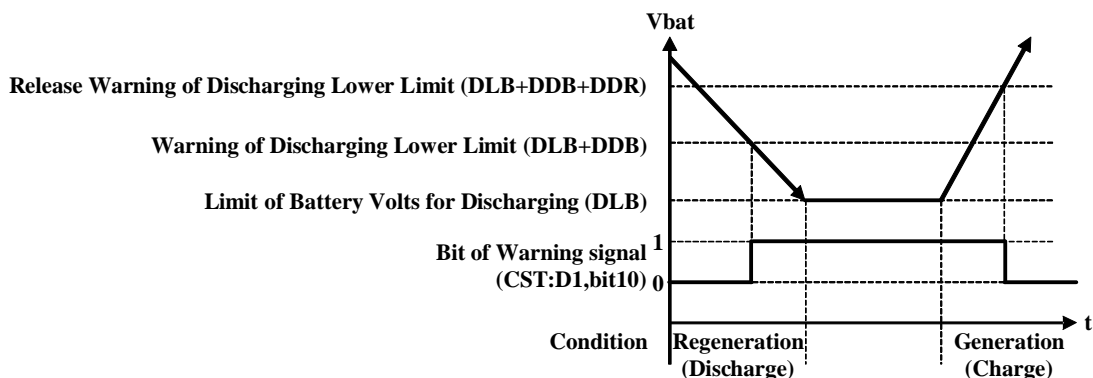

Battery Over Discharging Protection Timing Chart

- Battery rump up
This function forces the converter to charge the battery even in that the battery voltage is lower than Battery Under Voltage.
This function can be selected for charged up capacitor of battery side from 0V and/or for operation as bus converter.
Charging over discharged battery forcibly, that do not recommend .

2.Related parameters

- CVB
Set the limit of battery voltage for charging.
Format of this parameter is normalized Q14 format (nominal value is 48V).
CVB in command No3 "Write CV Charging Parameter Command" and CVB in command No7 "Write Battery Configuration Parameter1 Command" is same parameter write it in either. If both command are used, setting value is last command's.
- DLB
Set the limit of battery voltage for discharging.
Format of this parameter is normalized Q14 format (nominal value is 48V).
Please set this parameter higher than Under Battery Voltage.
- CDB
Set the deviation of volts for warning of charging upper limit.
Format of this parameter is normalized Q14 format (nominal value is 48V).
- DDB
Set the deviation of volts for warning of discharging lower limit.
Format of this parameter is normalized Q14 format (nominal value is 48V).
- CCR
Set deviation of voltage for cancel warning of charging upper limit.
Set by deviation between CDB and voltage for cancel warning of charging upper limit in normalized Q13 format (nominal value is 48V).
ex) case CDB =46V and voltage for cancel warning of charging upper limit = 45V, set deviation is 1V.
- DDR
Set deviation of voltage for cancel warning of discharging lower limit.
Set by deviation between DDB and voltage for cancel warning of charging upper limit in normalized Q14 format (nominal value is 48V).
ex) case DDB = 42V and voltage for cancel warning of discharging lower limit = 44V, set deviation is 2V.

*When the battery voltage is more than "Limit of Battery Voltage for Charging (CVB)" or less than "Limit of Battery Voltage for Discharging (DLB)", those status reflect to "CST" in "Inquire Converter Status Command".

3.Setting table about BCF

bit	bit2		bit1		bit0		BCF data	
Function	battery bus ramping up		battery over discharging protection		battery over charging protection		D0	D1
Setting	enable	0	disable	0	disable	0	0x00	0x00
	enable	0	disable	0	enable	1	0x01	0x00
	enable	0	enable	1	disable	0	0x02	0x00
	enable	0	enable	1	enable	1	0x03	0x00
	disable	1	disable	0	disable	0	0x04	0x00
	disable	1	disable	0	enable	1	0x05	0x00
	disable	1	enable	1	disable	0	0x06	0x00
	disable	1	enable	1	enable	1	0x07	0x00