

Z⁺200 Series

IEC 61000

DATA

DWG. No. IA709-58-01		
APPD	CHK	DWG
15/5/12 <i>J</i>	Don B. 14/5/12	<i>Yumi</i> 08.01.2012

INDEX**PAGE**

1. Electrostatic Discharge Immunity Test (IEC61000-4-2)	R-1
2. Radiated Radio-Frequency Electromagnetic Field Immunity Test (IEC61000-4-3)	R-2
3. Electrical Fast Transient / Burst Immunity Test (IEC61000-4-4)	R-3
4. Surge Immunity Test (IEC61000-4-5)	R-4
5. Conducted Disturbances Induced by Radio-Frequency Field Immunity Test (IEC61000-4-6)	R-5
6. Power Frequency Magnetic Field Immunity Test (IEC61000-4-8)	R-6
7. Voltage Dips, Short Interruptions Immunity Test (IEC61000-4-11)	R-7
8. Input Current Harmonics Test (IEC61000-3-2)	R-8

Terminology used

* Test results are typical data. Nevertheless the following results are considered to be actual capability data because all units have nearly the same characteristics.

1. Electrostatic Discharge Immunity Test (IEC61000-4-2)

(1) Equipment used

Electrostatic discharge simulator: ESS-2000 (NOISEKEN)

Discharge resistance: 330Ω Capacitor: 150pF

(2) Test conditions

Input voltage: 115,230Vac Output voltage: 100%

Output current: 100% Polarity: -,+

Number of tests: 10 times Ta: 25°C

Discharge interval: >1 Second

(3) Test method and Device test point

Contact discharge: FG, Case screw

Air discharge: Input and Output terminal

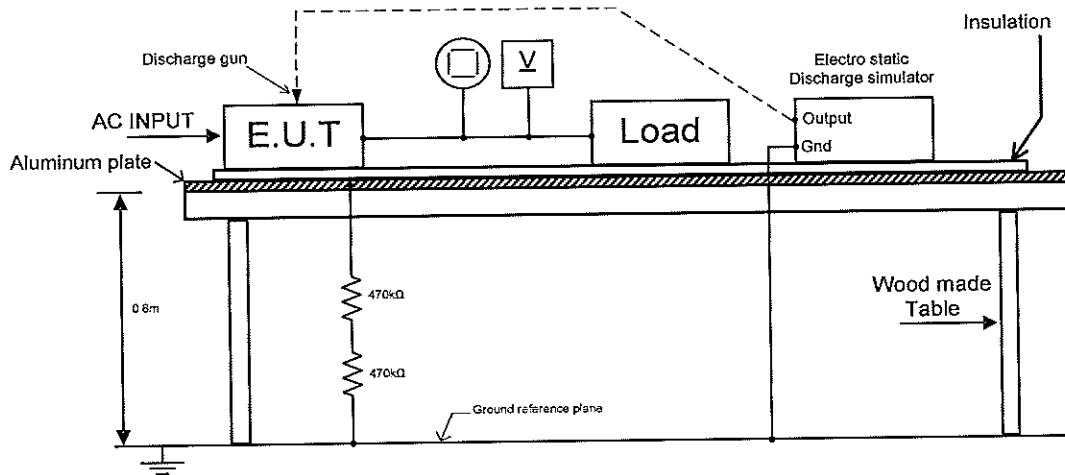

(4) Acceptable conditions

1. Output voltage regulation not to exceed ± 5% of initial (before test) value during test.
2. Output voltage to be within regulation specification after the test.
3. Along with 1 and 2, no discharge of fire or smoke, as well as no output failure.

(5) Test Result

Contact Discharge (KV)	Z36-6	Air Discharge (KV)	Z36-6
4	PASS	8	PASS

2. Radiated Radio-Frequency Electromagnetic Field Immunity Test (IEC61000-4-3)

(1) Equipment used

Test Laboratory: Hermon Laboratories Ltd.

(2) Test conditions

Input voltage: 115,230Vac

Output voltage: 100%

Output current: 100%

Amplitude Modulated: 80%, 1kHz

Electromagnetic Frequency: 80~1000MHz

Ambient temperature: 25°C

Distance: 2.4m

Wave Angel: Horizontal and Vertical

Sweep condition: 1.0% Step Up, 2.8 second Hold

Test Angle: Top/Bottom, Both Sides, Front/Back

(3) Test Method:

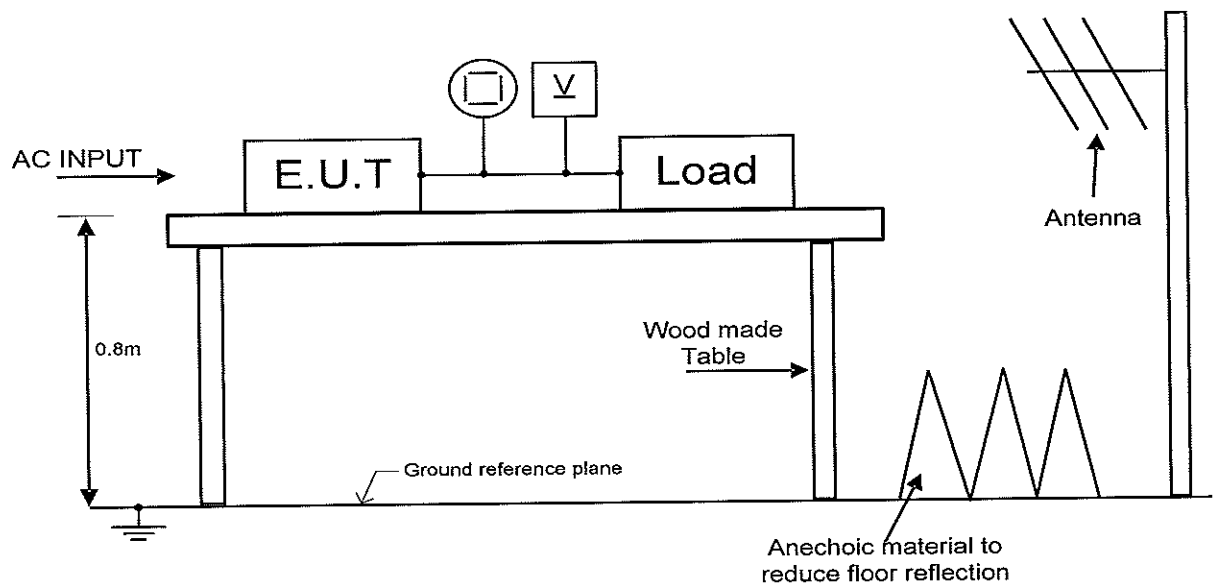

(4) Acceptable conditions

1. Output voltage regulation not to exceed $\pm 5\%$ of initial (before test) value during test.
2. Output voltage to be within regulation specification after the test.
3. Along with 1 and 2, no discharge of fire or smoke, as well as no output failure.

(5) Test Result

Radiated Field Strength (V/m)	Z36-6
3	PASS

3. Electrical Fast Transient / Burst Immunity Test (IEC61000-4-4)

(1) Equipment used

EFT/B Generator: SCHAFFNER NSG2025

(2) Test conditions

Input voltage: 115,230Vac

Output voltage: 100%

Output current: 100%

Test time: 1 minute

Polarity: -,+

Ambient temperature: 25°C

Number of tests: 3 times

(3) Test method and Device test point

Neutral (N), Line (L), Ground (FG) apply pulses from EFT/B Generator to N, L, FG separately, as well as, all at the same time.

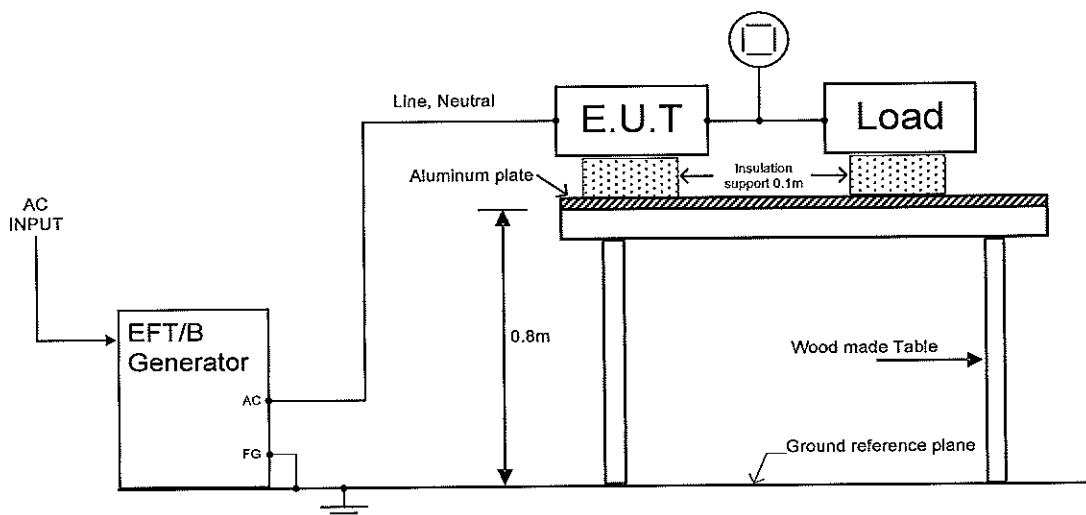

(5) Acceptable conditions

1. Output voltage regulation not to exceed $\pm 5\%$ of initial (before test) value during test.
2. Output voltage to be within regulation specification after the test.
3. Along with 1 and 2, no discharge of fire or smoke, as well as no output failure.

(5) Test Result

Test Voltage (kV)	Repetition Rate (kHz)	Z36-6
2	5	PASS

4. Surge Immunity Test (IEC61000-4-5)

(1) Equipment used

Surge Generator: NSG651 (SCHAFFNER)

Coupling impedance: Common - 12Ω Normal - 2Ω

Coupling capacitance: Common - 9 uF Normal - 18 uF

Coupling network: CDN110 (SCHAFFNER)

(2) Test method and devise test point

Input voltage: 115,230Vac Output voltage: 100%

Output current: 100% Number of tests: 5 times

Polarity: -,+ Ambient temperature: 25°C

Phase: 0°, 90°

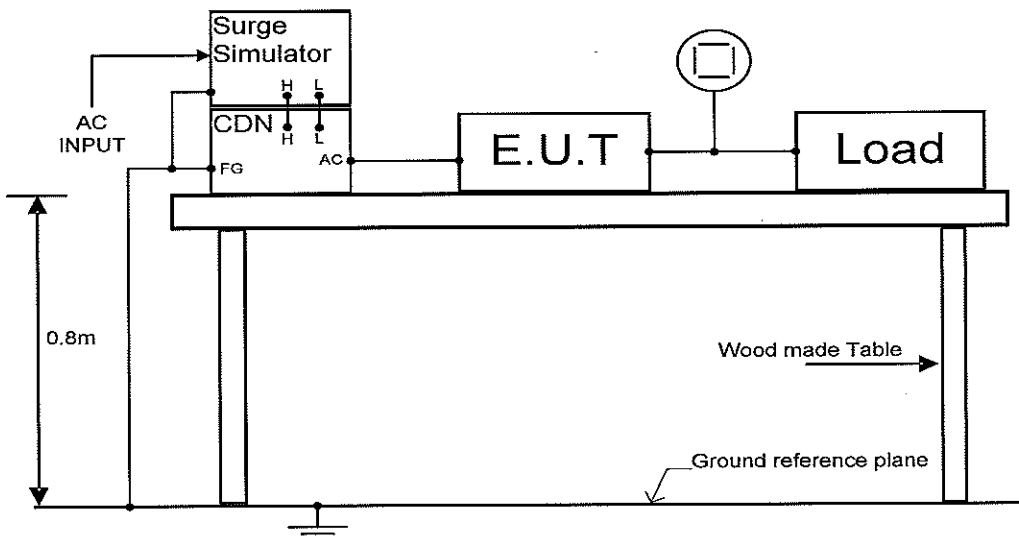

(3) Acceptable conditions

1. Output voltage regulation not to exceed ± 5% of initial (before test) value during test.
2. Output voltage to be within regulation specification after the test.
3. Along with 1 and 2, no discharge of fire or smoke, as well as no output failure.

(4) Test Result

Test Voltage (kV) Common	Z36-6	Test Voltage (kV) Normal	Z36-6
1.0	PASS	1.0	PASS
2.0	PASS		

5. Conducted Disturbances Induced by Radio-Frequency Field Immunity Test (IEC61000-4-6)

(1) Equipment used

RF Signal Generator 10kHz-1050MHz:	Fluke,6061A
RF Amplifier 10kHz-220MHz,150W:	Amplifier Research,150L
Coupling/Decoupling Network:	HL CDN 801-M3

(2) Test Condition:

Output voltage: 100%	Electromagnetic Frequency: 150kHz~80MHz
Input voltage: 115,230Vac	Type of modulation: AM 80% @ 1khz
Output current: 100%	Test Voltage: 3V _{rms} prior to modulation
	Dwell Time: 3s
	Frequency Step: 1.0% of current frequency

Ambient temperature: 25°C

(3) Test Method:

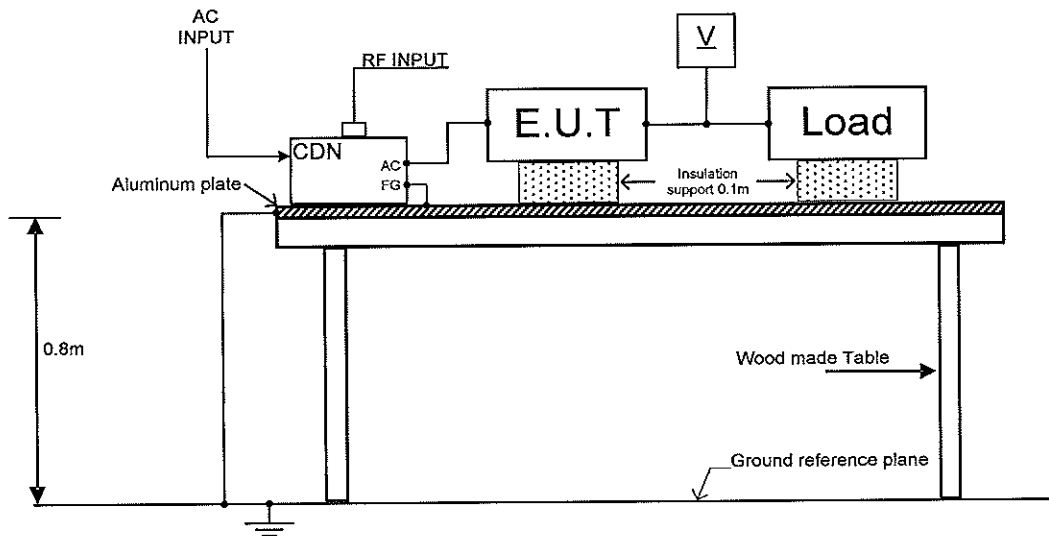

(4) Acceptable conditions

1. Output voltage regulation not to exceed ± 5% of initial (before test) value during test.
2. Output voltage to be within regulation specification after the test.
3. Along with 1 and 2, no discharge of fire or smoke, as well as no output failure.

(5) Test Result

Test Voltage Level (V)	Z36-6
3	PASS

6. Power Frequency Magnetic Field Immunity Test (IEC61000-4-8)

(1) Equipment used

Test Laboratory: Hermon Laboratories Ltd.

(2) Test Condition:

Input voltage: 115,230Vac	Output voltage: 100%
Output current: 100%	Frequency: 50Hz
Magnetic Field Strength: 30A/m	Direction: X, Y, Z
Duration Time: 10min.	Ambient temperature: 25°C

(3) Test Method:

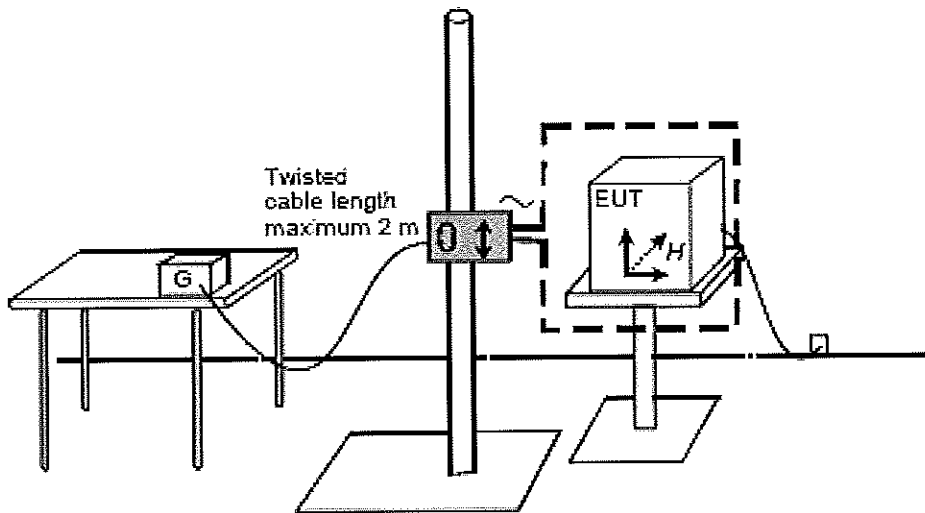

(4) Acceptable conditions

1. Output voltage regulation not to exceed $\pm 5\%$ of initial (before test) value during test.
2. Output voltage to be within regulation specification after the test.
3. Along with 1 and 2, no discharge of fire or smoke, as well as no output failure.

(5) Test Result

EUT positions	Result
X	PASS
Y	PASS
Z	PASS

7. Voltage Dips, Short Interruptions Immunity Test (IEC61000-4-11)

Z200

(1) Equipment used

AC Source: 6590 (CHROMA)

Oscilloscope: DL1740EL (Yokogawa)

(2) Test Condition:

Input voltage: 115,230Vac

Output voltage: 100%

Output current: 100%

Frequency: 50Hz

Repetition: 0.1Hz

Ambient temperature: 25°C

Number of tests: 3 times

(3) Test Method:

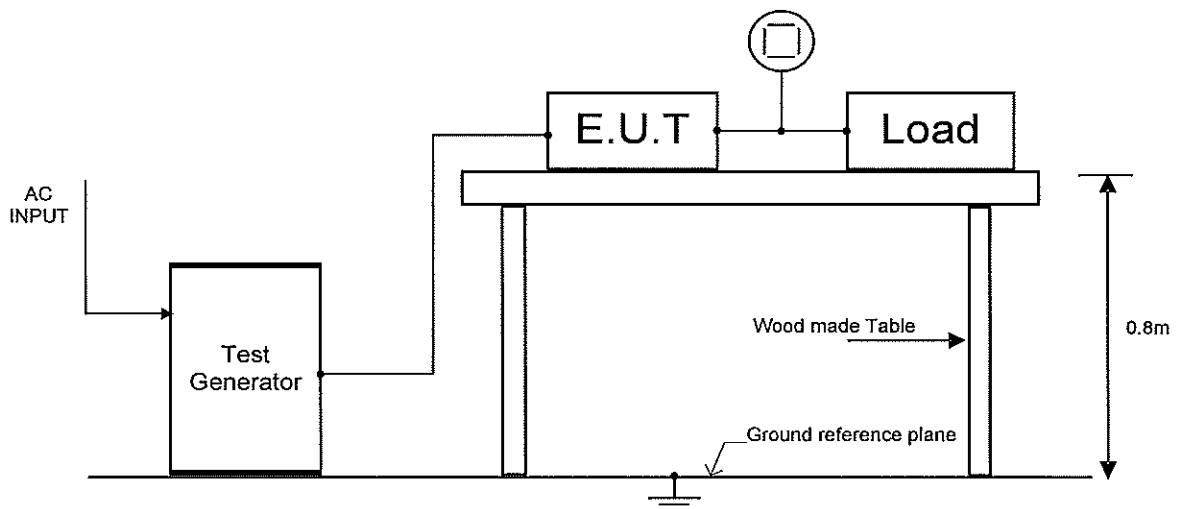

(4) Acceptable conditions

1. Output voltage to be within output voltage regulation specification after the test.
2. Along with 1 and 2, no discharge of fire or smoke, as well as no output failure.

(5) Test Result

Test level	Dip rate	Continue time t_s	Result
70%	30%	500ms	PASS
40%	60%	200ms	PASS
0%	100%	5000ms	PASS

8. Input Current Harmonics Test (IEC61000-3-2)

Z200

(1) Equipment used

AC Power Analyzer: WT110 (Yokogawa)

AC Source: 6590 (CHROMA)

(2) Test conditions:

Input voltage: 115, 230Vac

Output current: 100%

Output Voltage: 100%

(3) Test Method:

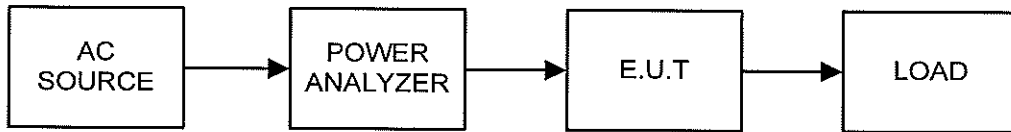

Vin: 115Vac

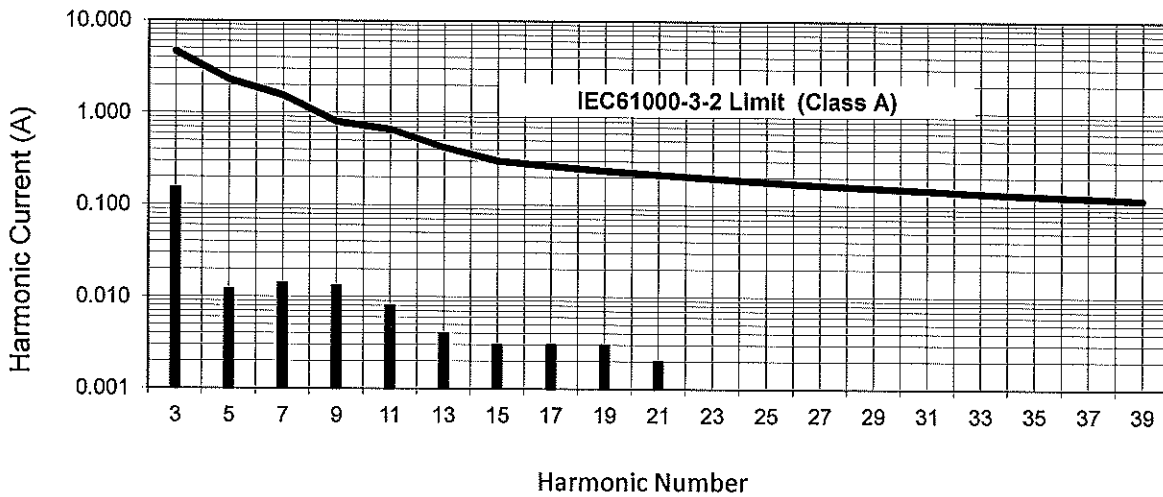

Vin: 230Vac

