

ZBM20 Series Instruction Manual

BEFORE USING THE PRODUCT

Be sure to read this instruction manual thoroughly before using this product. Pay attention to all cautions and warnings before using this product. Incorrect usage may lead to an electrical shock, damage to the unit or a fire hazard.

DANGER

Never use this product in locations where flammable gas or ignitable substances are present.

INSTALLATION WARNING

- When installing, ensure that work is done in accordance with the instruction manual. When installation is improper, there is risk of electric shock and fire.
- Installation shall be done by service personnel with necessary and appropriate technical training and experience. There is a risk of electric shock and fire.
- Do not cover the product with cloth or paper etc. Do not place anything flammable around. This might cause damage, electric shock or fire.

WARNING ON USE

- Do not touch this product or its internal components while circuit in operation, or shortly after shutdown. You may receive a burn.
- While this product is operating, keep your hands and face away from it as you may be injured by an unexpected situation.
- There are cases where high residual voltage remains inside the product. Therefore, do not touch even if they are not in operation as you may get injured due to high voltage and high temperature. You may also get electric shock or burn.
- Do not make unauthorized changes to this product nor remove the cover as you might get an electric shock or might damage the product. We will not be held responsible after the product has been modified, changed or dis-assembled.
- Do not use this product under unusual condition such as emission of smoke or abnormal smell and sound etc. Please stop using it immediately and turn off the product. It may lead to fire and electric shock. In such cases, please contact us. Do not attempt to repair, as it is dangerous for the user.
- Do not operate and store these products in environments where condensation occurs due to moisture and humidity. It may lead to fire or electric shock.
- Do not drop or apply shock to this product. It may cause failure. Do not operate these products when mechanical stress is applied.

CAUTION ON MOUNTING

- Follow connections to input/output terminals indicated in the instruction manual before switching on.
- Input/output wires are to be short and thick as possible.
- Do not use this product in special environment with strong electromagnetic field, corrosive gas or conductive substances and direct sunlight, or places where product is exposed to water or rain.
- Mount this product properly in accordance with the instruction manual, mounting direction and shall be properly ventilated.
- Please turn off the input power when doing wiring to connect to the input/output of the product.
- When installing in environment where conductive foreign, dust and liquid may be present, please consider penetration and take actions to prevent the above foreign material from entering the buffer module by installing filter. In order to prevent trouble or malfunction.

CAUTION ON USE

- Product individual notes are shown in the instruction manual. If there is any difference with common notes, individual notes shall have priority.
- Before using this product, be sure to read the catalog and instruction manual. There is risk of electric shock or damage to the product or fire due to improper use.
- Input voltage, buffer current, buffer power, ambient temperature and ambient humidity should be kept within specifications, otherwise the product will be damaged, or cause electric shock or fire.
- If the built-in fuse is blown, do not use the product even after replacing the fuse, as there is risk of abnormality inside. Kindly request repair to our company.

 **CAUTION ON USE**

- This product with built-in protection circuit, depending on usage conditions, built-in protection circuit may not work. It is recommended to provide a separate protection circuit (element, fuse, etc.), insert fuse at the input to prevent smoke, fire during abnormal operation.
- This product is made for general purpose electronic equipment use and is not designed for applications requiring high safety (such as extremely high reliability and safety requirements. Even though high reliability and safety are not required, this product should not be used directly for applications that have serious risk for life and physical safety). Take sufficient consideration in fail-safe design (such as providing protective circuit or protective device inside the system).
- When used in environments with strong electromagnetic field, there is possibility of product damage due to malfunction.
- When used in environment with corrosive gas (hydrogen sulfide, sulfur dioxide, etc.), there is possibility that they might penetrate the product and lead to failure.
- When used in environments where there is conductive foreign matter or dust, there is possibility of product failure or malfunction.
- Provide countermeasure for prevention of lightning surge voltage as there is a risk of damage due to abnormal voltage.
- Connect together the frame ground terminal of the product and the ground terminal of the equipment for safety and noise reduction. If these ground is not connected together, there is a risk of electric shock.
- Take care not to apply external abnormal voltage to the input/output. Especially, applying reverse voltage or overvoltage more than the rated voltage to the input/output as it may cause failure, electric shock or fire.
- Depending on product failure mode, there is possibility of hazardous voltage occurrence at the input/output terminal. Therefore, the input/output of this product must be protected in the end use equipment to maintain SELV.
- This product contains a printed circuit board utilizing surface mounted devices. PCB stress such as bending, twisting, etc., could cause damage. Please handle with care.

NOTE

- When disposing product, follow disposal laws of each municipality.
- Published EMI (CE, RE) or immunity is the result when measured in our standard measurement conditions and may not satisfy specification when mounted and wired inside end-user equipment. Use the product after sufficient evaluation is done at the actual end-user equipment.
- When exporting our products, apply the necessary permissions as required by rules and regulations of Foreign Exchange and Foreign Trade Control Act.
- Catalogue or contents of the instruction manual may be changed without a prior notice. Refer to latest catalogue or instruction manual.
- Reproduction or reprinting the instruction manual or its portion is not allowed without our permission.

LONG-TERM STORAGE METHOD AND LONG-TERM STORAGE PERIOD

- Please keep the product in carton box.
- Please do not apply excessive vibration, shock or mechanical stress applied directly to the product.
- Please keep away from direct sunlight.
- Temperature and humidity should be within range of product specification (with no condensation)
- For long-term storage temperature and humidity, the following conditions shall be used as a guideline :
 Temperature range : 5°C~30°C
 Humidity range : 40%~60%RH
 Please keep away from the places where temperature and humidity can change drastically
 It can cause condensation on the product or deterioration.
- For long-term storage period, we recommended to use within 2 years after receiving the product.
 There is tendency that the leakage current of the aluminium electrolytic capacitors may increase when stored without using for a long time.
 This phenomenon can be improved by applying voltage to the aluminium electrolytic capacitors to reduce the increased leakage current through the self-recovery effect of the electrolyte.
 For reference, before using products that have been stored for a very long time, please warm-up first for 30 minutes or more without taking load.
 < Criterion of warm up voltage condition >
 (1) Implementation period : 1 year or above after the delivery
 (2) Electrical continuity condition
 Input voltage : Rating
 Load : 0A
 Ambient temperature : Normal temperature
 Time : 30 minutes or more

Note: CE MARKING

CE Marking, when applied to a product covered by this handbook indicates compliance with the following:

- Low Voltage Directive in that it complies with EN62368-1.
- EMC Directive
- Restriction of the use of certain Hazardous Substances Directive

1. Model Name Identification Method

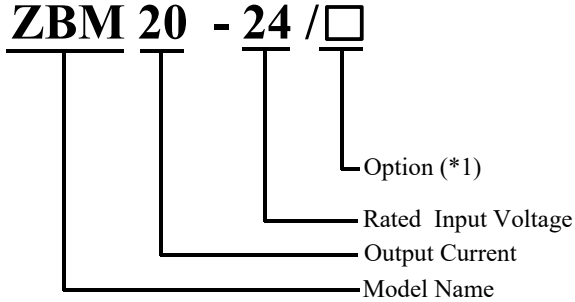

- (*1) Blank : Standard type
 /L : with chassis model
 /A : with chassis and cover model
 /T : extended buffer time
 /CO : With coating on solder side of PCB model
 /CO2 : With coating on both sides of PCB model

2. Terminal Explanation

Figure 1

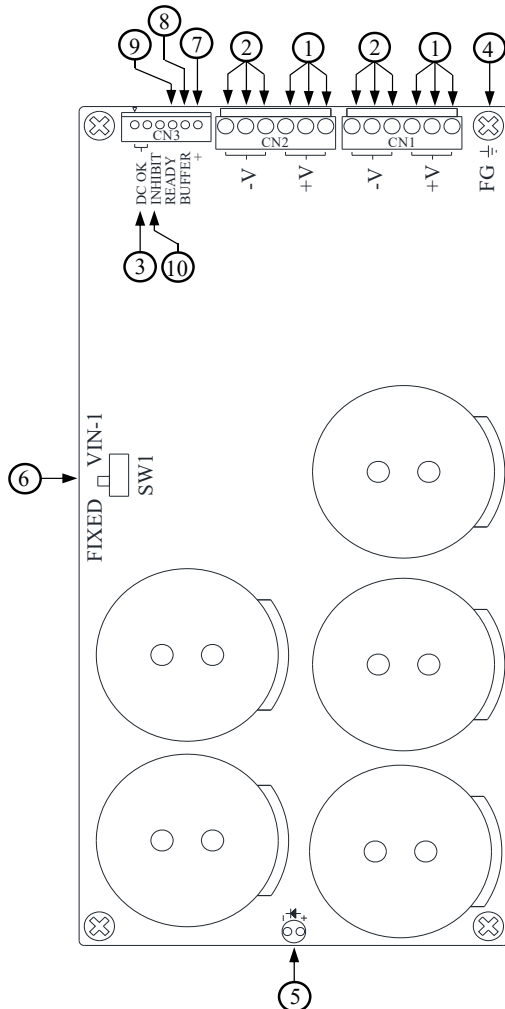

- ① +V: +Input/Output terminal
- ② -V: -Input/Output terminal
- ③ DC OK: Relay (Photo Mosfet). Logic low when input voltage is within specification.
- ④ \perp : Earth terminal
- ⑤ GREEN LED: Bulk voltage monitor. LED is off when bulk electrolytic capacitor is within SELV level.
- ⑥ Buffer Level: SW1 switch right for Fixed mode and switch left for VIN-1 mode.

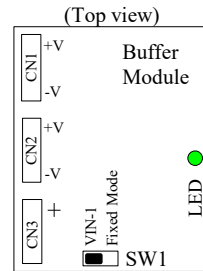

- ⑦ + : Common supply 3.3 – 30V(max)
- ⑧ Buffer: signal will turn “high” during buffering mode.
- ⑨ Ready: signal will turn “high” during ready mode.
- ⑩ Inhibit: pull to TTL “low” to activate the inhibit mode.

3. Terminal Connecting Method

Pay attention to the input wiring. If it is connected to wrong terminal, the buffer module will be damaged.

- When connecting input and output wiring, input voltage should be off .
- The \perp terminal must be connected to the \oplus protective earth terminal or chassis of the equipment.
- When connecting or removing input and output wires, do not apply stress to unit.
- Power supply should be fixed directly to the input connector of the buffer module. Please refer to wiring diagram shown in 3-1 below.

3-1 Wiring for power supply and buffer module.

(1) General input/output wiring

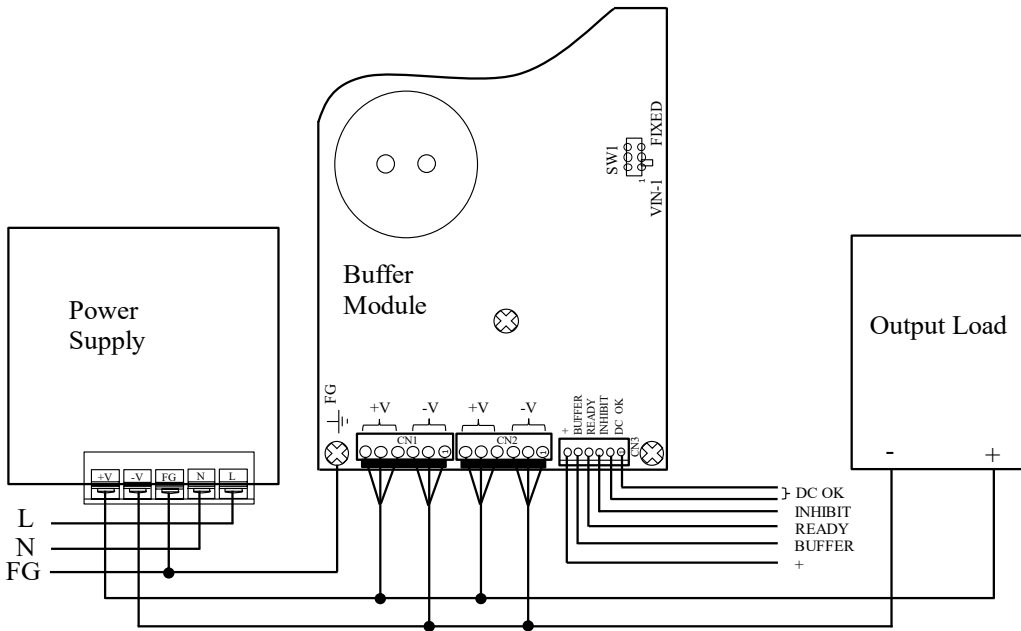

Figure 2

(2) Parallel of buffer units

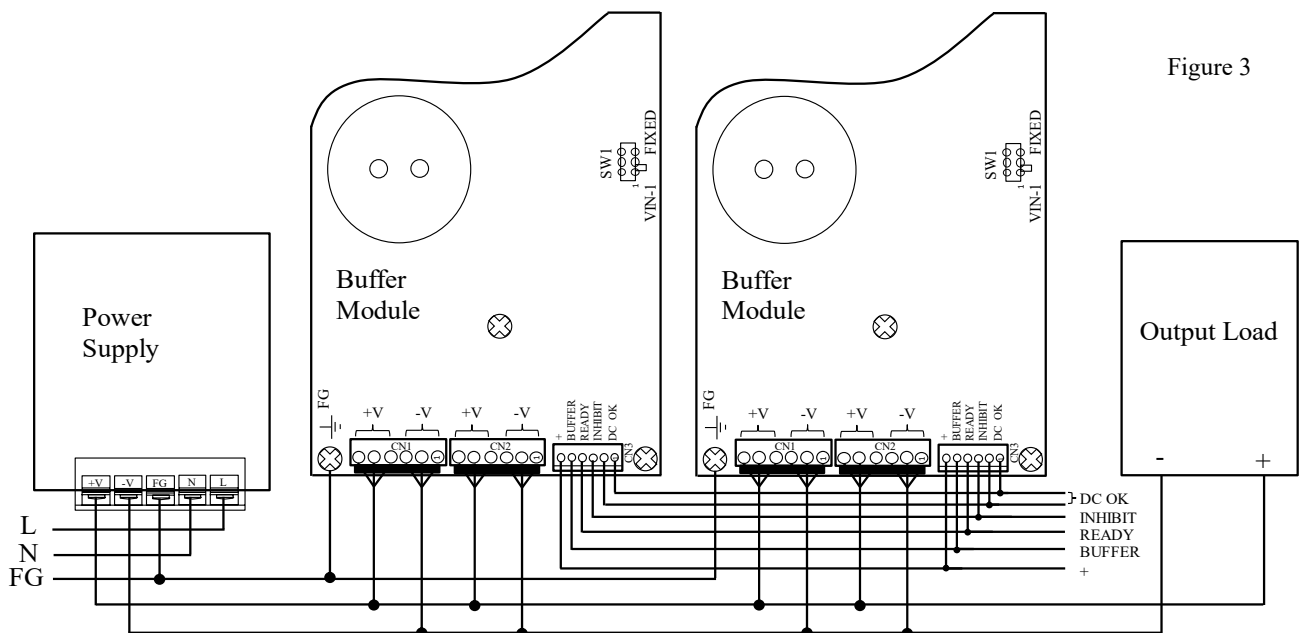

Figure 3

(3) Signal wiring with internal voltage supply

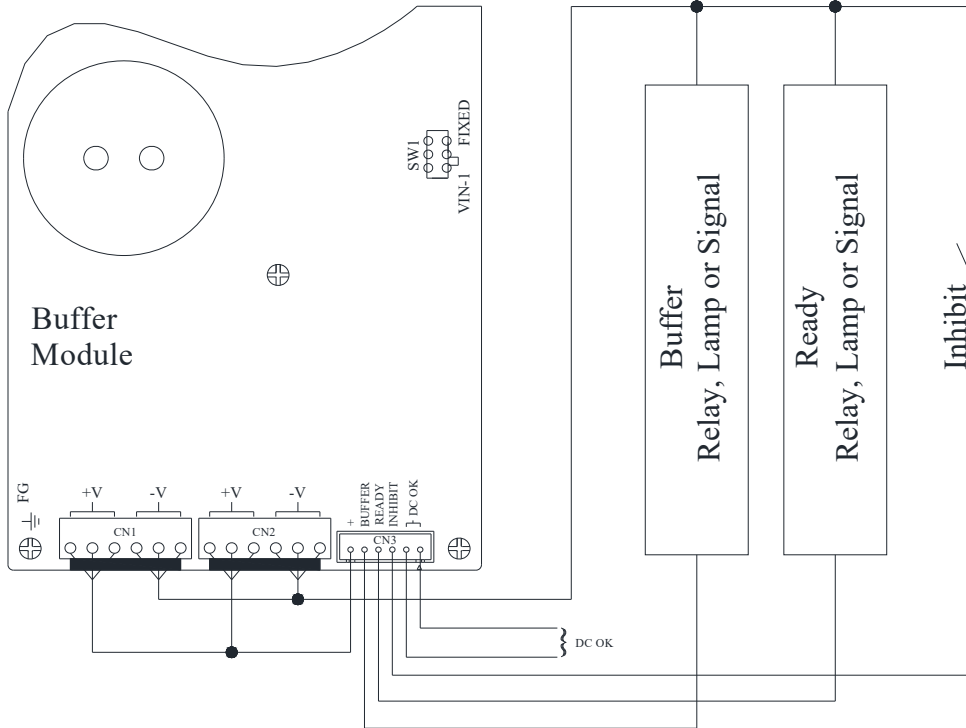

Figure 4

NOTE : Please refer to figure 7 for DC OK connection.

(4) Signal wiring with external voltage supply

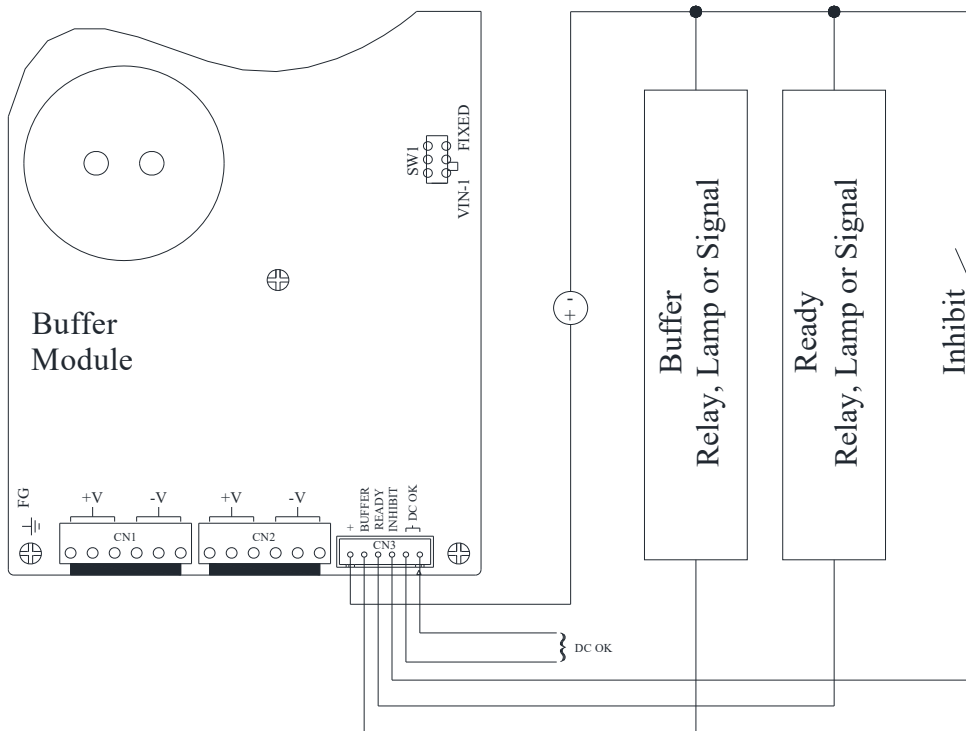

Figure 5

NOTE : Please refer to figure 7 for DC OK connection.

4. Explanation of Functions and Precautions

4-1. Input Voltage Range

4-1.1 Fixed mode, input voltage range :

Fixed mode	ZBM20		
	24V	15V	12V
Input voltage range (VDC)	23 - 30	14.4 - 18	11.5 - 14.4

4-1.2 VIN-1 mode, input voltage range :

VIN-1 mode	ZBM20		
	24V	15V	12V
Input voltage range (VDC)	24 - 30	Not Available	

Input voltage which is out of specification or reversed, may damage the unit.

4-2. Nominal Buffer Voltage Range

4-2.1 Fixed mode, during buffering mode the nominal buffer voltage level :

Fixed mode	ZBM20		
	24V	15V	12V
Nominal buffer voltage level (VDC)	22.4	13.8	11

4-2.2 VIN-1 mode, during buffering mode the nominal buffer voltage range :

VIN-1 mode	ZBM20		
	24V	15V	12V
Input voltage range (VDC)	22 - 29.4	Not Available	

Caution on use :

- a) Kindly take note that the buffer voltage is equal to the input voltage during ready mode.

4-3. Signal Output

4-3.1 Relay signal is present at the DC OK terminal as indication of the status of input voltage at the input terminal. In normal operation relay DC OK is close if it is greater or open if it is lower then the threshold voltage mentioned below :

	ZBM20		
	24V	15V	12V
DC OK typical threshold voltage (V)	19	12	10

NOTE : Measured at Ta = 25°C

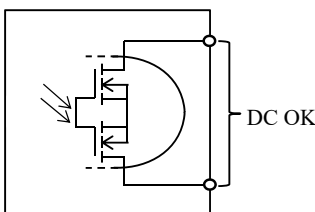

Figure 6
DC OK relay rating:
30V(max) / 200mA(max)

4-3.2 Ready and buffer signals as indicator of the operation status of the buffer module. Ready signal will change to logic high when the bulk electrolytic capacitors charged up to more than 220Vdc typically after start up. During buffering mode, buffer signal will change to logic high.

Ready and buffer signals with 10mA max. are common supply type with voltage range mentioned below :

	ZBM20		
	24V	15V	12V
Common supply voltage range (V)	3.3 - 30	3.3 - 18	3.3 - 14.4

Caution on use :

- a) Kindly take note that both signals may be mistriggered during brown out conditions.
b) In ready mode, buffer signal may appear if dynamic load occurred.

4-3.3 Inhibit signal with 10mA max. is common supply type with voltage range mentioned below :

	ZBM20		
	24V	15V	12V
Common supply voltage range (V)	3.3 - 30	3.3 - 18	3.3 - 14.4

Inhibit function can be activated by simply pulling the inhibit signal line to logic low. The buffer unit will immediately stop the existing charging or buffering operation and start to discharge the energy stored in the bulk electrolytic capacitors to the safe level in about 3 ~ 5 seconds.

Caution on use :

- a) Please do not touch the buffer module immediately after the inhibit function because of high voltage might still present across the bulk electrolytic capacitors.

Please refer to figure 7 for general connection diagram of signals.

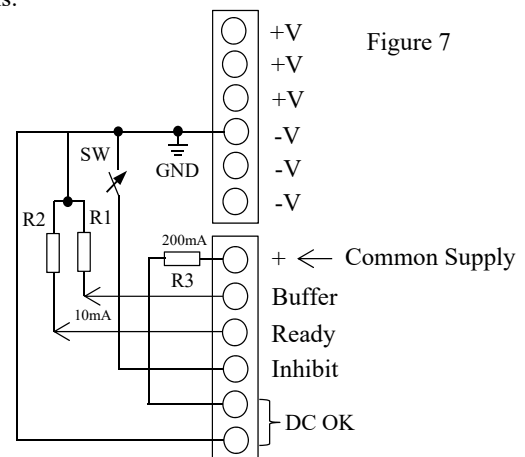

Figure 7

For example :

Common supply	R1 = R2	R3
12V±10%	1500Ω ±5% (1W)	150Ω ±5% (3W)

4-4. Fixed Mode and Vin-1 Mode

Buffer module provides two option for buffer voltage that is fixed mode and Vin-1 mode. Executed using toggle switch to choose between the two options. (refer to Figure 1)
 At fixed mode where in buffer voltage is set at 22.5V is mainly for 24V fixed output voltage upstream power supply . While in Vin-1 mode, the buffer voltage is typically 1V lower than the regulated output voltage of the power supply source. Vin-1 mode is suitable for adjustable output upstream power supply, this is to keep buffer voltage as close as possible to the regulated output voltage of the power supply.

4-5. Input Over Voltage Protection (OVP)

Input OVP circuit will shut down the boost converter if the input to the buffer module is greater than figure below :

	ZBM20		
	24V	15V	12V
Input voltage (V)	>30	>18	>14.4

If the input drops back to the normal operating range or less than the value mentioned above, the buffer module will operate as per normal again.

4-6. Over Current Protection (OCP)

The OCP function is provided for the buffer voltage. When the buffering current exceeds 105% of the maximum DC buffer current specification, OCP operation will be activated. The buffering current will be automatically recovered when overload condition is removed.

4-7. Parallel Operation

The buffer module can be connected in parallel to increase the buffer time. Please refer to wiring diagram shown in 3-1 (2) for parallel connection. The total output current and charge current must not exceed the maximum output current of the upstream power supply. The voltage may drop due to the overcurrent protection of the upstream power supply.

4-8. Series Operation

Not possible.

4-9. Buffer Module Operation

The product can be used to :

- a) To extend the hold up time after AC loss.

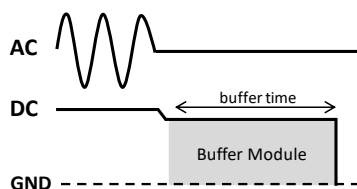

- b) To bridge mains failure.

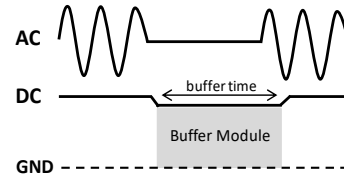

4-10. The Buffer Current versus Buffer Time for Fixed Mode and Nominal buffer Voltage

- a) ZBM20-24 :
Buffer time : 0 – 2 seconds

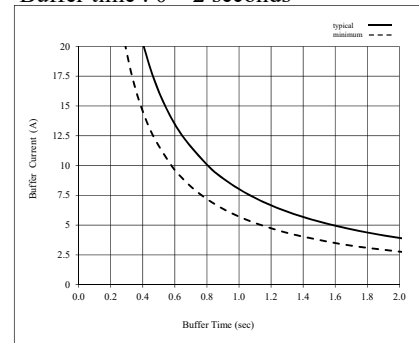

NOTE : Ta=25°C and initial capacitance.

- b) ZBM20-15 :
Buffer time : 0 – 2 seconds

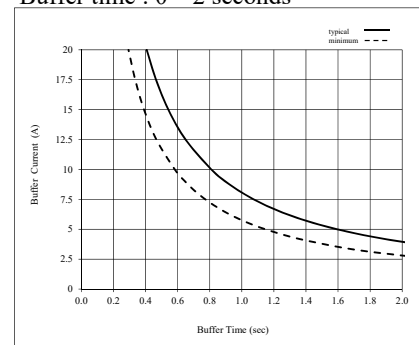

NOTE : Ta=25°C and initial capacitance.

- c) ZBM20-12 :
Buffer time : 0 – 2 seconds

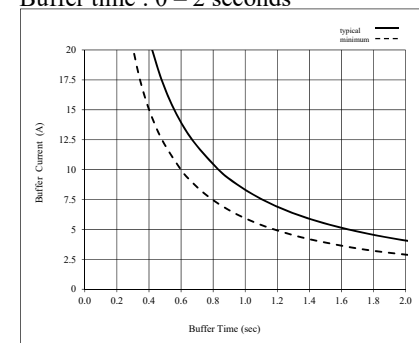

NOTE : Ta=25°C and initial capacitance.

Kindly refer to product specifications for more details regarding buffer time.

4-11. Buffer Ripple & Noise

The standard specification for maximum ripple value is measured according to measurement circuit shown in figure 8. When load lines are longer, ripple becomes larger. In this case, electrolytic capacitor, film capacitor, etc might be necessary across the load terminal.

Figure 8

C = Film capacitor 0.1 μ F parallel with
 electrolytic capacitor 100 μ F
 R = Resistive load

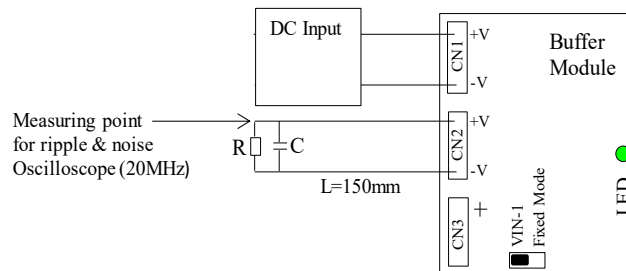

4-12. The Timing Sequence Chart

- (1) The buffer module is connected to the upstream power supply. After AC input to the power supply, the output from the power supply which is connected to the input/output of the buffer module will charge up the internal circuit of the buffer module.
- (2) Once the input/output voltage reaches the threshold voltage of DC OK circuit, the DC OK signal will change from logic high to logic low.
- (3) After approximately 40s, the bulk electrolytic capacitors voltage will be charged up to 220Vdc typical and the ready signal change from logic low to logic high.
- (4) If the AC input shutdown or brown out conditions, the output voltage from the upstream power supply will go down. In this case, the input/output voltage of the buffer module will go down as well. The buffer module senses this change and it will activate buffer mode. Please refer to section 4-2. for the nominal buffer voltage level that the buffer module to supply back to the output line of the upstream power supply.

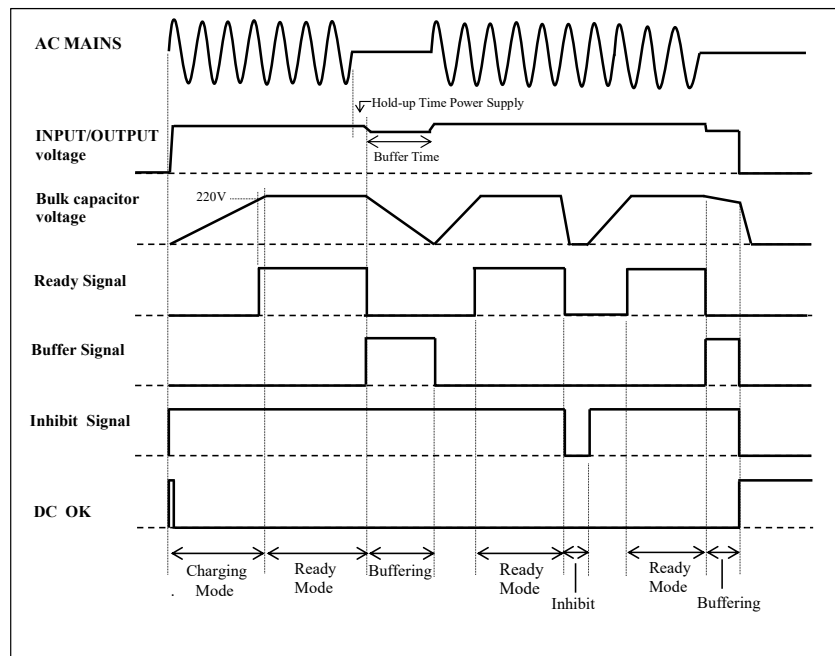

- (5) While buffering take place, buffer signal will change from logic low to high. And ready signal will change from logic high to low.
- (6) During the upstream power supply is still turn ON and customer system will like to activate the inhibit function by pulling inhibit signal from logic high to logic low, the buffer module will shut down the internal converters and bulk electrolytic capacitors will be discharged in 3 ~ 5s.
- (7) Once the inhibit function is deactivated, buffer module will resume to normal operation automatically.

4-13. The Block Diagram

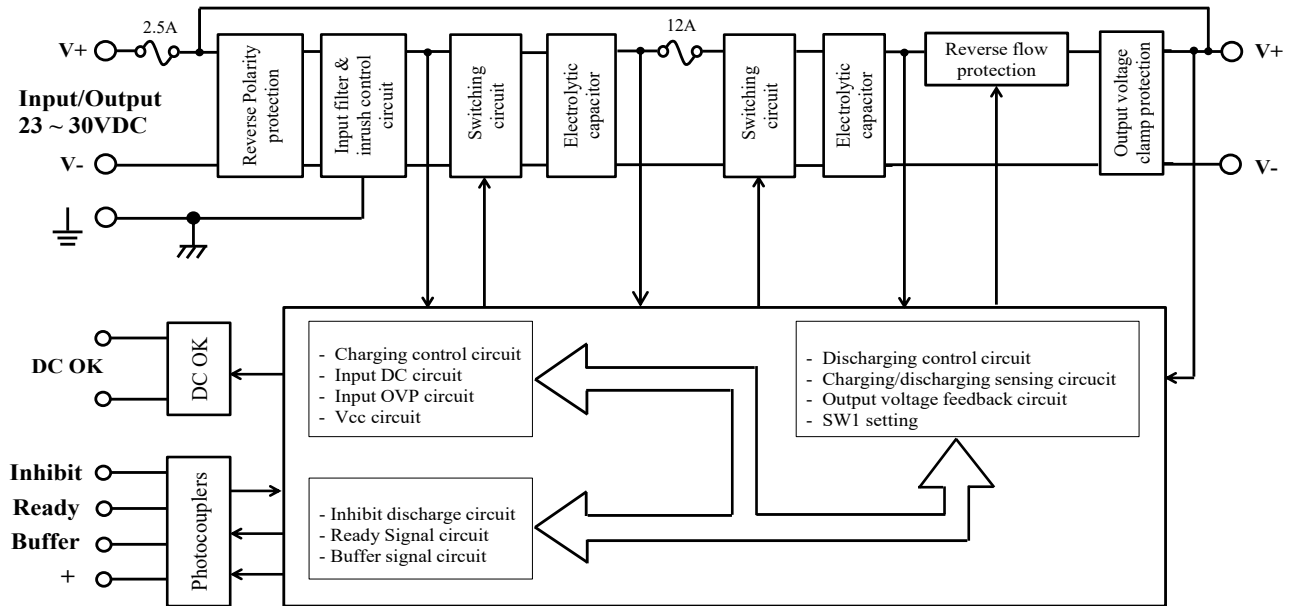

- Circuit topology, switching frequency
 Boost converter, typical 100kHz
 Buck converter, typical 65kHz
- Fuse rating :
 2.5A and 12A

4-14. Isolation Test

Isolation resistance between input/output & signal ports to FG (Chassis) shall be more than 100MΩ at 500VDC. For safety purposes, voltage setting on DC isolation tester must be done before the test. Ensure that the unit is fully discharged after the test.

Input/Output & signal ports ~ FG (chassis): 500VDC, 100MΩ or more

Figure 9

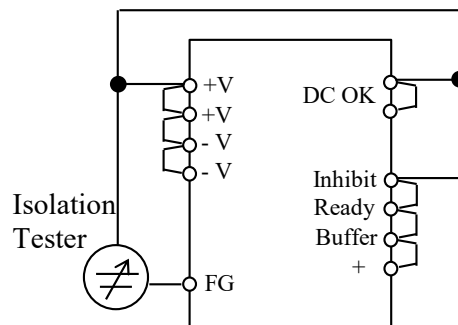

4-15. Withstand Voltage

This series is designed to withstand 500VAC between input/output & signal ports to FG (chassis) for 1 minute. When testing withstands voltage, set current limit of withstand voltage test equipment at 100mA. The applied voltage must be gradually increased from zero to testing value and then gradually decreased for shut down. When timer is used, the buffer module may be damaged by high impulse voltage at timer switch on and off. Connect input/output & signal ports as follows :

Input/Output & signal ports ~ FG (chassis) : 500VAC 1min 100mA

Figure 10

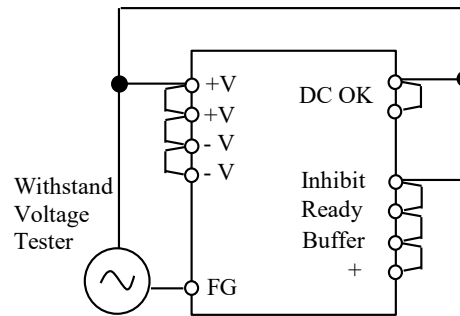

5. Mounting

5-1. ZBM20 Series : There are 6 mounting directions recommended.

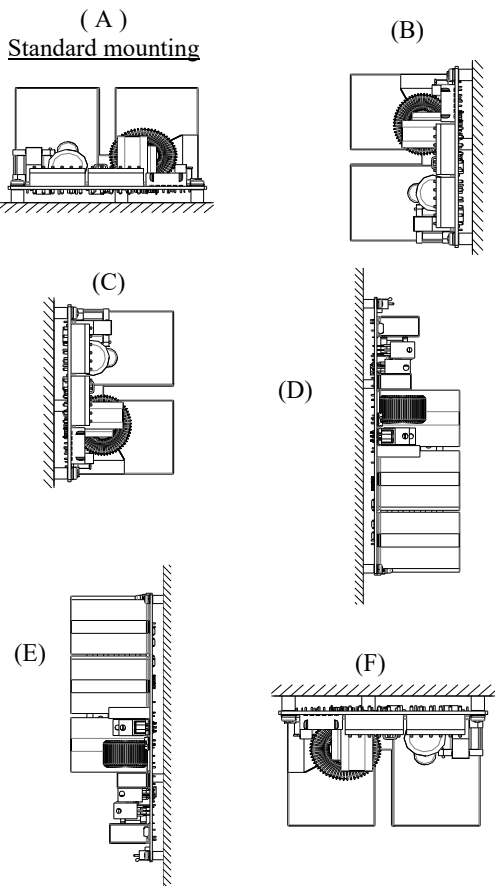

5-2. ZBM20/A Series : There are 6 mounting directions recommended.

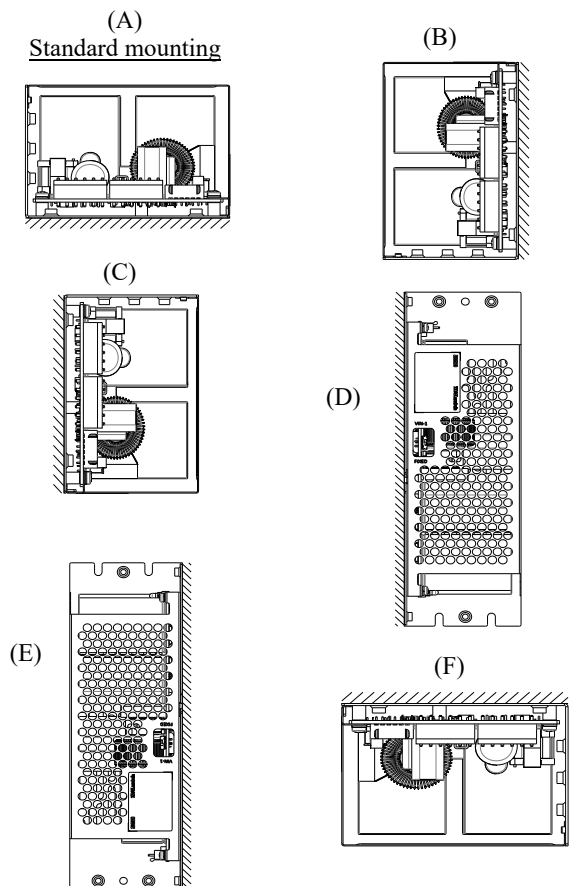

5-3. Mounting Spacing

Do not exceed the buffer deratings. Please refer to section 6. Leave enough space surround the units to ventilate heat efficiently.

Figure 11

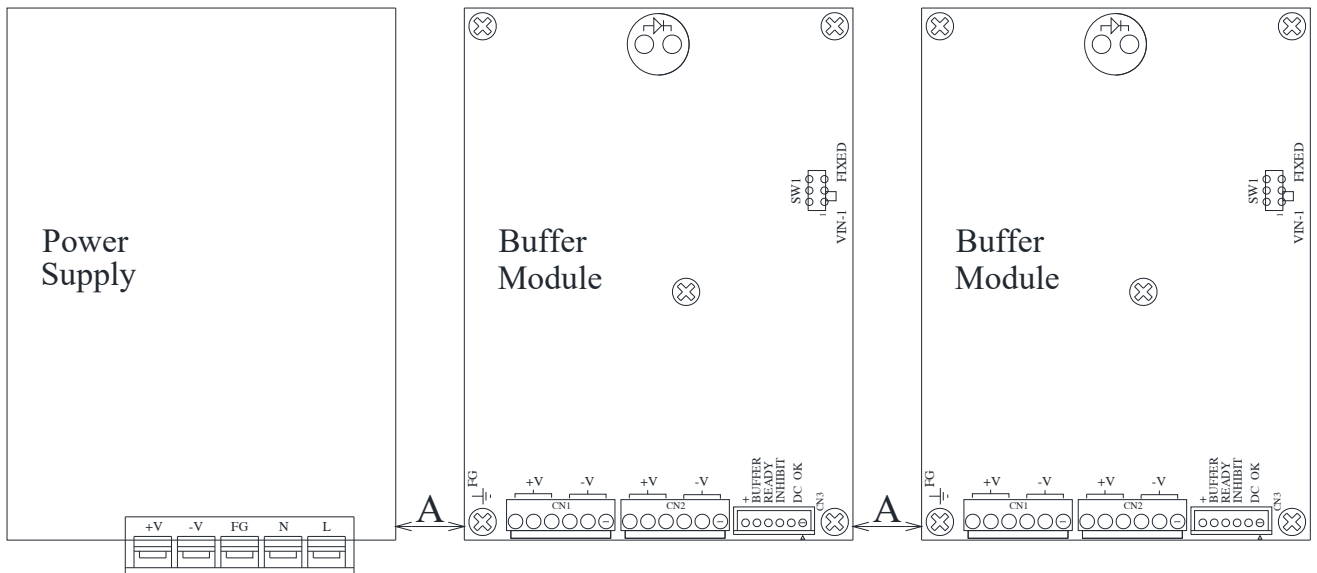

Minimum Installation clearances:

A=5mm which is recommended on the left and right side when products are permanently loaded with full 480W in Ready mode.

In case the adjacent device is a heat source, A=15mm clearance is recommended.

5-4. \perp

\perp must be connected to the protective earth terminal of the equipment. Mounting holes must be connected to the chassis (conductor) by metal spacer. When screw clamping the mounting holes, please use the screw with spring washer. If not connected to the chassis(conductor), the conducted noise, radiation noise and output noise will increase. (The location of mounting holes for chassis connection is shown with mark \perp in figure 12.)

Figure 12

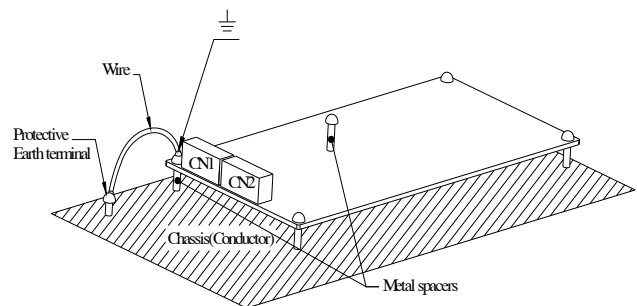

5-5. Mounting Method

- Insert the spacer (Max Ø6) of height more than 8mm to lift the unit. And use all mounting holes A for the unit installation.

The vibration specification is specified under this mounting condition.

- (1) Mounting holes size :
 5 holes Ø 3.2mm

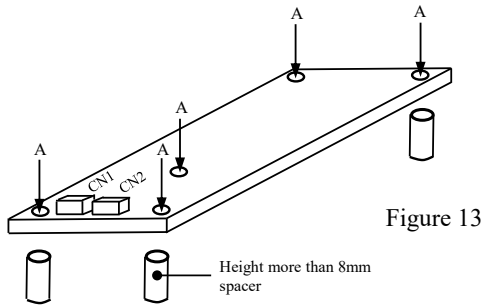

Figure 13

- Mounting condition to meet Isolation & Withstand Voltage standard.

- Allowable area by metal pieces is 7mm from each PCB corners and additional position at the center of PCB.

Refer to figure 14 below for more detail.

Figure 14

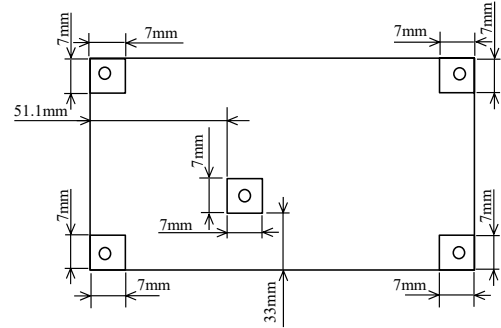
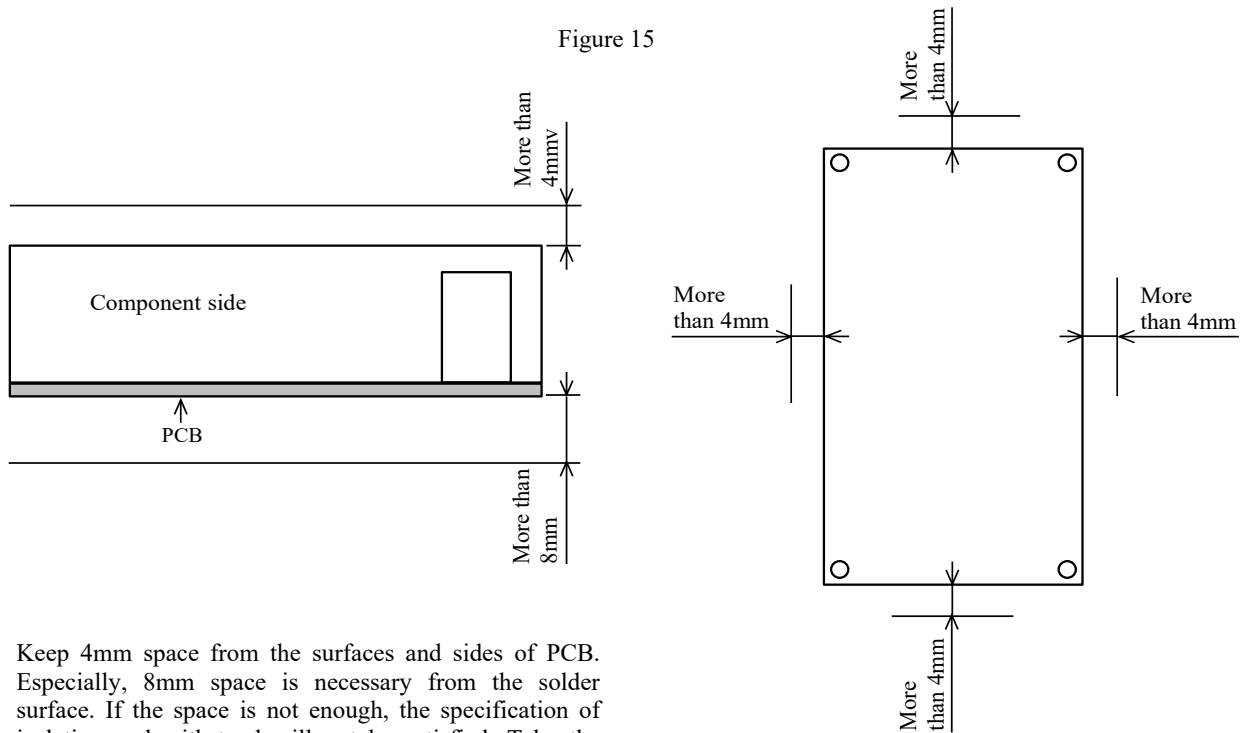

Figure 15



- Keep 4mm space from the surfaces and sides of PCB. Especially, 8mm space is necessary from the solder surface. If the space is not enough, the specification of isolation and withstand will not be satisfied. Take the space in the buffer module surroundings and the upper area of components to keep enough for convection cooling.

6. Buffer Derating

ZBM20 and ZBM20/A series.

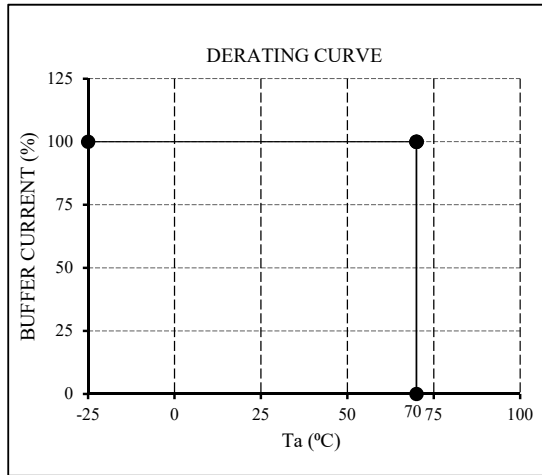

7. The Life Expectancy

The life expectancy of buffer module depends on the life of the built-in aluminium electrolytic capacitors. The life is described in reliability data.

The life of the aluminium electrolytic capacitor varies depending on the method of mounting the buffer module, the load current and the ambient temperature. Please refer to the “Electronic Capacitor Lifetime”.

Please do not use the product which passed over the life expectancy. There is a risk of unexpected buffer shutdown and specifications may not be satisfied.

Please contact us for maintenance or exchange the product which exceeded the life expectancy.

8. EMC

The ZBM20 series complies with the provisions of the EMC directive and meets the following standards :

Emissions: EN55032 Class B, CISPR32-B

Immunity: EN61000-4-2, -3, -4, -5, -6

EMI (CE) compliance to be confirmed at system level.

Product is considered as a peripheral accessory to power supply.

9. Wiring Method

Use all wires as thick and short as possible to make lower impedance. Noise can be eliminated by attaching capacitor to the load terminals.

For safety and EMI considerations, connect \perp terminal to protective earth terminal of equipment.

Caution on use :

- Kindly keep the input wires as short as possible, this is to avoid mistriggering of signals during dynamic load condition.

10. ZBM20 and ZBM20/A series

Wiring recommendation		
Model Type	Connector	Wire (AWG)
CN1 and CN2	Input/Output +V, -V	16 - 22
CN3	Signal (DC OK, Inhibit, Ready, Buffer, +)	22 - 30

- Wire requirement is rated at minimum 105°C and to use copper conductor only.
- For use in a Pollution degree 2 environment only.
- These products are considered for use where maximum ambient temperature does not exceed 70°C. When installing these products please refer to section 6 for derating.
- Recommended for indoor use.

11. Accessory

Connectors used :

Part Description	Part name	Manufacturer	Quantity
Pin header (CN1 & CN2)	B6P-VH(LF)(SN)	J.S.T	2
Pin header (CN3)	B6B-XH-A(LF)(SN)	J.S.T	1

Matching housing, Pins & Tool (Not included with the product) :

Part Description	Part name	Manufacturer	Quantity
Socket housing (CN1 & CN2)	VHR-6N	J.S.T	2
Socket housing (CN3)	XHP-6	J.S.T	1
Terminal Pins	SVH-41T-P1.1	J.S.T	12
Terminal Pins	SXH-002T-P0.6	J.S.T	6

12. Warranty period

This product is warranty for a period of 5 years from the date of shipment.

For damage occurring at normal operation within this warranty period, repair is free of charge.

Please read the General Safety Instruction before using the products.

Product marking :

TDK-Lambda

TDK-Lambda Singapore Pte. Ltd.

(Sales, Services and R&D)

1008 Toa Payoh North #06-01/08, #07-01/03

Singapore 318996

Telephone: +65 62517211

Facsimile: +65 62509171

WEBSITE: www.tdk-lambda.com.sg

13. Before concluding that the unit is at fault...

Before concluding that the unit is at fault, make the following checks.

Check if the rated input voltage is connected.

Check if the wiring of input and output is correct.

Check if the wire size is not too thin. Refer to section 10.

Check if the buffer current and wattage is not over specification.

Check if the GREEN LED lights up during ready mode and Buffer mode.

Audible noise can be heard during dynamic load buffering mode operation.

14. Returns

Please contact your local sales office or visit our website to arrange return of any faulty product.