

# Programmable Power Supplies

EN

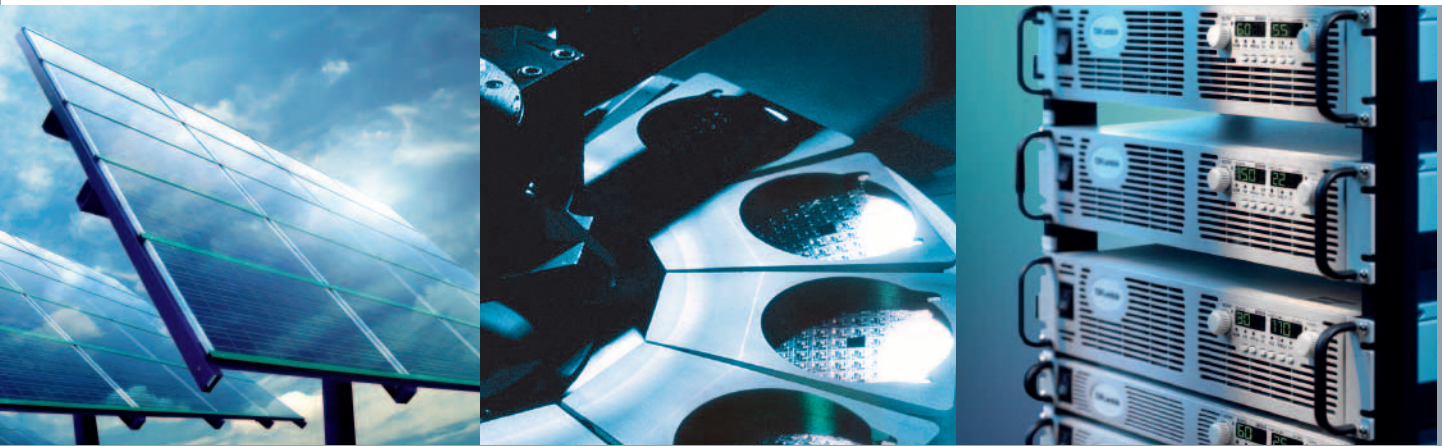

**TDK-Lambda**  
*Innovating Reliable Power*



## Contents

Page

Page

### **NEW** Z<sup>+</sup> 4

Product range / How to order [Z<sup>+</sup> 200/400/600/800 W](#) 6

Front panel description [Z<sup>+</sup> 200/400/600/800 W](#) 7

Rear panel description [Z<sup>+</sup> 200/400/600/800 W](#) 8

Specifications [Z<sup>+</sup> 200 W](#) 9

Specifications [Z<sup>+</sup> 400 W](#) 12

Specifications [Z<sup>+</sup> 600 W](#) 15

Specifications [Z<sup>+</sup> 800 W](#) 18

Outline Drawings [Z<sup>+</sup> 200/400/600/800 W](#) 21

### **Configurations** 23

### **Programming Options** 23

### **Options** 24

### **Accessories** 25

### **Genesys™** 26

### **GEN/GENH 750/1500 W** 30

Product range / How to order [GENH 750 W](#) 28

Front / Rear panel description [GENH 750 W](#) 29

Product range / How to order [GEN 750/1500 W](#) 30

Front / Rear panel description [GEN 750/1500 W](#) 31

Specifications [GEN/GENH 750/1500 W](#) 32

Accessories [GEN/GENH 750 W](#) 37

### **NEW** Genesys™ Power Sink (Option) [GEN 750/1500 W](#) 38

Specifications Power Sink (Option) [GEN 750 W](#) 40

Specifications Power Sink (Option) [GEN 1500 W](#) 42

Outline Drawings [GENH 750 W](#) 46

Outline Drawings [GEN 750/1500 W](#) 47

### **GEN 2400 W** 48

Product range / How to order [GEN 2400 W](#) 48

Front / Rear panel description [GEN 2400 W](#) 49

Specifications [GEN 2400 W](#) 50

Outline Drawings [GEN 2400 W](#) 56

### **GEN 3.3 kW** 58

Product range / How to order [GEN 3.3 kW](#) 58

Front / Rear panel description [GEN 3.3 kW](#) 59

Specifications [GEN 3.3 kW](#) 60

Outline Drawings [GEN 3.3 kW](#) 66

### **GEN 5 kW** 68

Product range / How to order [GEN 5 kW](#) 68

Front / Rear panel description [GEN 5 kW](#) 69

Specifications [GEN 5 kW](#) 70

Outline Drawings [GEN 5 kW](#) 76

### **NEW** Genesys™ Fast Speed (Option) [GEN 3.3/5 kW](#) 78

Specifications Fast Speed (Option) [GEN 3.3/5 kW](#) 79

### **GEN 10/15 kW** 80

Product range / How to order [GEN 10/15 kW](#) 80

Front / Rear panel description [GEN 10/15 kW](#) 81

Specifications [GEN 10/15 kW](#) 82

Outline Drawings [GEN 10/15 kW](#) 87

### **Configurations** 88

### **Programming Options** 88

### **Software** 91

### **Accessories** 92

### **ZUP** 94

Product range / How to order [ZUP 200/400/800 W](#) 95

Front / Rear panel description [ZUP 200/400/800 W](#) 95

Specifications [ZUP Series](#) 96

Front / Rear panel description [GP485A](#) 100

Specifications [GP485A](#) 100

Outline Drawings [ZUP 200/400](#) 101

Outline Drawings [ZUP 800 W](#) 102

### **Configurations** 104

### **Programming Options** 104

### **Rack mounted ATE and OEM** 105

### **Options** 106

### **Accessories** 107

Many applications require more than a fixed voltage. Today's test systems and industrial processes require stable and accurate control of output voltage and current during operation with the facility to monitor these parameters.

Genesys™ and ZUP+ can provide the best solution for programmable power in many applications by offering comprehensive control and monitoring features that are intuitive and easy to use and not overly complex.

#### **Automotive**

- Component burn-in
- Fuel cell
- Lamp testing
- Component development
- Battery simulation

#### **Semiconductor**

- Burn-in
- Deposition
- Ion implantation
- Component lead electroplating
- MBE systems
- MOCVD for LED manufacture
- Solar cell manufacture

#### **Medical**

- X-Ray
- Oncology
- MRI
- Magnets
- Gradient amplifiers

#### **Aerospace & Defence**

- RF communication
- Satellite test systems
- Materials research
- ATE systems

#### **Diode Laser**

- Medical
- Marking
- Cutting
- Welding

#### **Test & Measurement**

- Large ATE systems
- Component test
- Analytical instrument
- Module and component burn-in
- Solar inverter testing

#### **Other Industrial**

- Water purification
- Plating and etching
- Capacitor forming
- Shipborne DC power

NEW

## Z<sup>+</sup> 200/400/600/800 W



The new generation Z<sup>+</sup> series of programmable DC power supplies offer high efficiency, flexibility, reliability and high power density.

Z<sup>+</sup> comes in 200W and 400W models with output voltages up to 100 V DC in a compact 2 U high format (600 W and 800W models will be added later). It is convenient for benchtop use, OEM equipment integration and rack mounting systems (up to 6 units into a 2 U rack).

Z<sup>+</sup> has USB and RS232/RS485 interfaces built-in as standard and other digital (LAN **LXI**-C compliant and GPIB) and isolated analogue interfaces are optional. It is fully communication and signal compatible with the existing Genesys family enabling mixed systems to use the same bus with ease.

Z<sup>+</sup> also has arbitrary function generation and up to 6 pre-programmed functions can be stored – ideal for automotive or laser simulation tasks.

### Features

- High Power Density 200/400/600/800 W in 2 U
- Wide Range Input (85 – 265 V AC Continuous)
- Active Power Factor Correction (0.99 typical)
- Output Voltage up to 100 V, Current up to 75 A
- Constant Voltage (CV)/(CC) Constant Current auto-crossover
- Built-in RS-232/RS-485 Interface Standard
- Global Commands for Serial RS-232/RS-485 Interface
- Auto-Re-Start /Safe-Start: user selectable
- Last-Setting Memory
- High Resolution 16 bit ADCs & DACs
- Low Ripple & Noise
- Variable Fan Speed Control
- Front Panel Lock selectable from Front Panel or Software
- Reliable Encoders for Voltage and Current Adjustment
- Parallel Operation with Active Current Sharing; up to Six identical units.
- Advanced Parallel Master/Slave. Total Current is Programmed and Measured via the Master.
- External Analog Programming and Monitoring (user selectable 0-5 V & 0-10 V)
- Reliable Modular and SMT Design
- 19" Rack Mount capability for ATE and OEM applications
- Optional Interfaces
  - Isolated Analog Programming and Monitoring Interface (0-5 V/0-10 V & 4-20 mA)
  - IEEE 488.2 SCPI (GPIB) Multi-Drop
  - **LXI**-C compliant LAN
- LabView® and LabWindows® drivers
- Five Year Warranty
- Worldwide Safety Agency Approvals; CE Mark for LVD and EMC Regulation



## Sequence programming Applications: ISO 16750-2

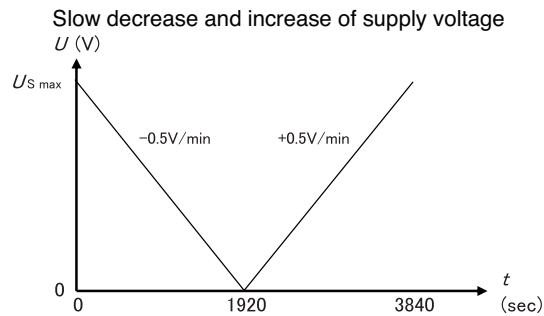
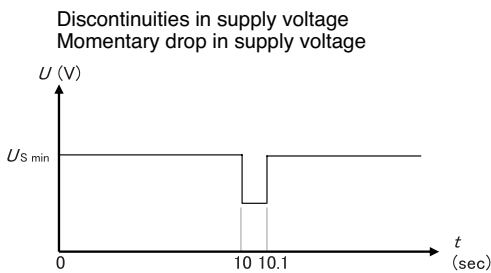
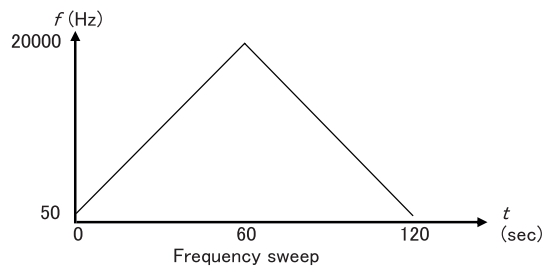
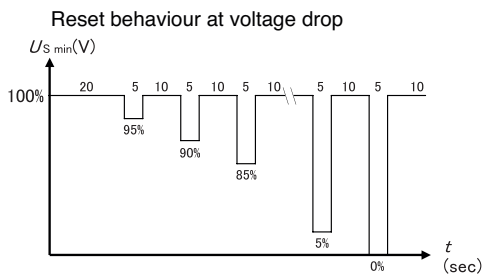
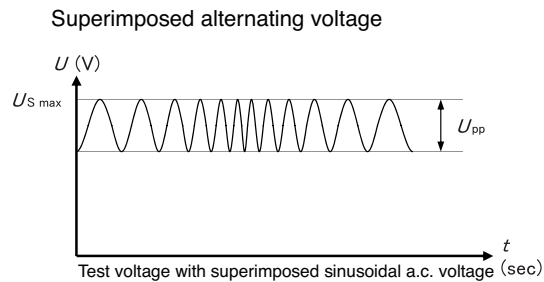
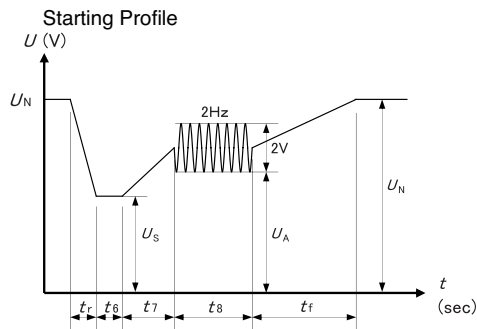

## Applications

**Z<sup>+</sup> series power supplies have been designed to meet the demands of a wide variety of applications.**

### Test and Measurement

Last-Setting Memory based on flash memory no battery or capacitor backup. Simplifies test design and requires.

Built-in RS-232/RS-485 gives maximum system flexibility along with 0-5 V and 0-10 V, selectable analog programming.

Wide range of available inputs allows testing of many different devices.

### Semiconductor Burn-in

Safe-Start may be ENABLED to re-start at Output OFF to protect load.

Wide range input (85-265 V AC) with Active Power Factor correction rides through input transients easily.

### Component Test

High power density, zero stacking and single wire parallel operation give maximum system flexibility.

### Laser Diode

OVP is directly set on Voltage Display, assuring accurate protection settings.

Fast constant Current fast response, no over shoot. Current Limit Fold Back assures load is protected from current surges.

### Heater Supplies

Smooth, reliable encoders enhance front panel control.

Remote analog programming is user selectable 0-5 V or 0-10 V.

### RF Amplifiers and Magnets

Robust design assures stable operation under a wide variety of loads. High linearity in voltage and current mode.

# Z<sup>+</sup> 200/400/600/800 W

Model	Output Voltage [V DC]	Output Current [A]	Output Power [W]
Z10-20	0~10	0~20	200
Z10-40		0~40	400
Z10-60*		0~60	600
Z10-75*		0~75	750
Z20-10	0~20	0~10	200
Z20-20		0~20	400
Z20-30*		0~30	600
Z20-40*		0~40	800
Z36-6	0~36	0~6	216
Z36-12		0~12	432
Z36-18*		0~18	648
Z36-24*		0~24	864
Z60-3.5	0~60	0~3.5	210
Z60-7		0~7	420
Z60-10*		0~10	600
Z60-14*		0~14	840
Z100-2	0~100	0~2	200
Z100-4		0~4	400
Z100-6*		0~6	600
Z100-8*		0~8	800

\* Coming soon mid 2012

## How to order

### Power Supply Identification / Accessories

Z	36	-	12	-		-		-	E
Series name	Output voltage (0~36 V)		Output current (0~12 A)		Option: IEEE IS510 IS420 LAN		Output Jacks L		AC Cable E - Europe GB - United Kingdom U - North America I - Middle East

### Factory Option

Factory Option	P/N:
USB Interface built-in Standard	-
RS-232/RS-485 Interface Built-in Standard	-
IEEE 488.2 (GPIB) Interface	IEEE
Voltage Programming Isolated Analog Interface	IS510
Current Programming Isolated Analog Interface	IS420
LAN Interface (Complies with <b>LXI</b> class C)	LAN
Front Panel Output Jacks (60 V or 25 A max)	L

## Front panel description Z+ 200/400/600/800 W

- ① AC ON/OFF Switch
- ② Air Intake allows zero stacking for maximum system flexibility and power density. \*
- ③ Reliable encoder controls Output Voltage and power supply setting.
- ④ Volt Display shows Output Voltage and directly displays and power supply settings.
- ⑤ Reliable encoder controls Output Current, and power supply setting.
- ⑥ Current Display shows Output Current and power supply setting.
- ⑦ Function/Status LEDs:
  - Alarm
  - Fold-back Mode
  - Fine Control
  - Remote Mode
  - Preview Settings
  - Output On
- ⑧ Pushbuttons allow flexible user configuration:
  - Coarse and Fine adjustment of Output Voltage/Current and Advanced Parallel Master or Slave.
  - Preview settings and set Voltage/Current with Output OFF, Front Panel Lockout.
  - Set OVP, UVP, UVL Limits
  - Set Current Fold-back
  - Local/Remote Mode and select Address and Baud rate.
  - Output ON/OFF and Auto-Start/Safe-Start Mode
  - Menu
- ⑨ Output Jacks available for models up to 60 V maximum output voltage and up to 25 A maximum output current

\* Zero stacking – side-by-side mounting of 6 units in a 19" Rack.



## Rear panel description Z+ 200/400/600/800 W

- ① Connector allows (Non-isolated) Analog Program and Monitor and other functions.
- ② Remote/Local Output Voltage Sense Connections.
- ③ Signales connector
- ④ RS-232/RS-485 IN Remote Serial Programming.
- ⑤ RS-485 Output to other Z+ Power Supplies.
- ⑥ USB Interface
- ⑦ Wide-Range Input 85-265 V AC continuous, 47/63 Hz with Active Power Factor Correction (0.99 typical)  
AC Input Connector: IEC320 -C16.
- ⑧ Exhaust air exits at the back. Allows vertical stacking of units without any separation between units.
- ⑨ Output Connections: Rugged busbars for 6 V up to 100 V Output.
- ⑩ Optional Interface Position for LAN Interface (shown).
- ⑪ Position for optional GPIB Interface.

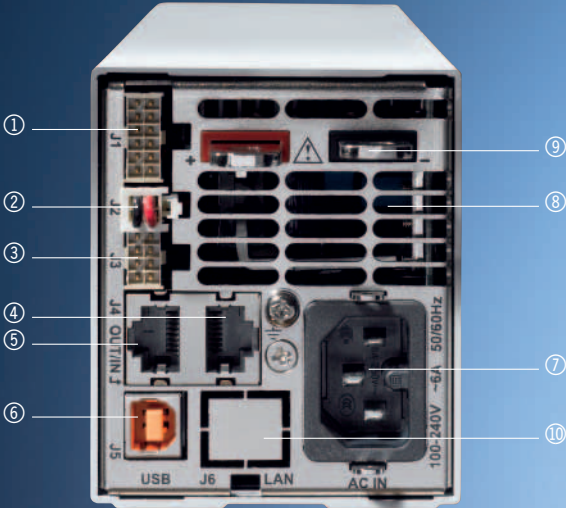

# Specifications Z<sup>+</sup> 200 W

Output Rating		Z	10-20	20-10	36-6	60-3.5	100-2
Rated output voltage (*1)		[V]	10	20	36	60	100
Rated output current (*2)		[A]	20	10	6	3.5	2
Rated output power		[W]	200	200	216	210	200
Constant Voltage Mode							
Max. Line regulation (*6)			0.01 % of rated output voltage +2 mV				
Max. Load regulation (*7)			0.01 % of rated output voltage +2 mV				
Ripple and noise (p-p, 20 MHz) (*8)		[mV]	50				80
Ripple r.m.s. 5 Hz~1 MHz		[mV]	5	6	7	8	
Temperature coefficient		[PPM/°C]	30PPM/°C from rated output voltage, following 30 minutes warm-up.				
Temperature stability			0.02 % of rated Vout over 8 hrs interval following 30 minutes warm-up. Constant line, load & temp.				
Warm-up drift			Less than 0.05 % of rated output voltage +2 mV over 30 minutes following power on.				
Remote sense compensation/wire		[V]	1	2	3	5	
Up-prog. Response time, 0~Vomax. (*9)		[ms]	15	30	50		
Down-prog. response time:	Full load (*9)	[ms]	10	25	30	40	50
	Time delay (*17)		210	250	320	380	1200
	No load (*10) (*15)(*17)		40	65	85	100	250
	No load (*10) (*16)(*17)		200	200	290	310	900
Transient response time		[ms]	Time for output voltage to recover within 0.5 % of its rated output for a load change 10~90 % of rated output current. Output set-point: 10~100 %, Local sense Less than 1 ms, for models up to and including 100 V				
Hold-up time			15 ms Typical.	16 ms Typical. Rated output power			
Constant Current Mode							
Max. Line regulation (*6)			0.01 % of rated output voltage +2 mA				
Max. Load regulation (*11)			0.01 % of rated output voltage +5 mA				
Load regulation thermal drift			Less than 0.05 % of rated output current over 30 minutes following load change.				
Ripple r.m.s. 5 Hz~1 MHz (*12)		[mA]	25	15	8	4	3
Temperature coefficient		[PPM/°C]	100PPM/°C from rated output current, following 30 minutes warm-up.				
Temperature stability			0.05 % of rated Iout over 8 hrs. interval following 30 minutes warm-up. Constant line, load & temperature.				
Warm-up drift			Less than ± 0.1 % of rated output current over 30 minutes following power on.				
Protective Functions							
Fold-back protection			Output shut-down when power supply change mode from CV to CC or CC to CV. User presetable. Reset by AC input recycle in autostart mode or by OUT button or by rear panel ENABLE, or by communication port.				
Over-voltage protection (OVP)			Inverter Shut down method. Reset by AC input recycle in autostart mode or by OUT button or by rear panel ENABLE, or by communication port.				
Over-voltage trip point		[V]	0.5-12	1~24	2~40	5~66	5~110
Output under voltage limit (UVL)			Preset by front panel or communication port. Prevents from adjusting Vout below limit. Does not affect in analog programming.				
Output under voltage protection (UVP)			Output shut-down when power supply output voltage goes below UVP programming. Reset by AC input recycle in autostart mode or by OUT button or by rear panel ENABLE, or by communication port.				
Over temperature protection			User selectable, latched or non latched.				

\*1: Minimum voltage is guaranteed to maximum 0.1 % of rated output voltage.

\*2: Minimum current is guaranteed to maximum 0.2 % of rated output current.

\*3: For cases where conformance to various safety standards (UL, IEC, etc...) is required, to be described as 100-240 V AC (50/60Hz).

\*4: Ta = 25 °C with rated output power.

Analog Programming and Monitoring		10-20	20-10	36-6	60-3.5	100-2
Vout voltage programming		0~100 %, 0~5 V or 0~10 V, user selectable. Accuracy and linearity: $\pm 0.5$ % of rated Vout.				
Iout voltage programming (*13)		0~100 %, 0~5 V or 0~10 V, user selectable. Accuracy and linearity: $\pm 1$ % of rated Iout.				
Vout resistor programming		0~100 %, 0~5/10 k $\Omega$ full scale, user selectable. Accuracy and linearity: $\pm 1$ % of rated Vout.				
Iout resistor programming (*13)		0~100 %, 0~5/10 k $\Omega$ full scale, user selectable. Accuracy and linearity: $\pm 1.5$ % of rated Iout.				
Shut-off (SO) control		By electrical Voltage: 0~0.6 V / 2~15 V or dry contact, user selectable logic.				
Output current monitor (*13)		0~5 V or 0~10 V, user selectable. Accuracy: $\pm 1$ %.				
Output voltage monitor		0~5 V or 0~10 V, user selectable. Accuracy: $\pm 1$ %.				
Power supply OK signal		4~5 V-OK, 0V-Fail. 500 $\Omega$ series resistance.				
Parallel operation		Possible, up to 6 units in master/slave mode with single wire current balance connection.				
Series operation		2 identical units (with external diodes).				
CV/CC indicator		Open collector. CC mode: On, CV mode: Off. Maximum voltage: 30 V, maximum sink current: 10 mA				
Interlock (ILC) control		Enables/Disables the PS output by dry contact (Short: On, Open: Off, Source current: less than 0.5 mA). Ena/Dis is activated by front panel.				
Local/Remote mode Control		By electrical signal or Open/Short: 0~0.6 V or short: Remote, 2~15 V or open: Local				
Local/Remote mode Indicator		Open collector (shunted by 36 V zener). On (0~0.6 V, 10 mA sink current max.) Remote. Off-Local (30 V max.).				
Trigger out		Maximum low level output = 0.8 V, Minimum high level output = 2 V, maximum source current = 8 mA, minimum pulse = 10 $\mu$ s ~ 20 $\mu$ s..				
Trigger in		Maximum low level input voltage = 0.8 V, minimum high level input voltage = 2.0 V, Maximum sink current = 8 mA, 10 $\mu$ s minimum positive edge trigger				
Programmed signal 1		Open collector, maximum voltage 25 V, maximum sink current 100 mA. (Shunted by 27 V zener)				
Programmed signal 2		Open collector, maximum voltage 25 V, maximum sink current 100 mA. (Shunted by 27 V zener)				
<b>Front Panel</b>						
Control functions		Multiple options with 2 Encoders				
		Vout/Iout manual adjust				
		OVP/UVL/UVP manual adjust				
		Protection Functions - OVP, UVL, UVP, Fold-back, OCP, INT, SO				
		Communication Functions - Selection of LAN, IEEE, RS232, RS485, USB				
		Communication Functions - Selection of Baud Rate, Address				
		Analog Control Functions - Selection Voltage/resistive programming, 5 V/10 V, 5 K/10 K programming				
		Analog Control Functions - Selection of Voltage/Current Monitoring 5 V/10 V, Output ON/OFF, Front Panel Lock.				
Display		Vout: 4 digits, accuracy: 0.5 % of rated output voltage $\pm 1$ count.				
		Iout: 4 digits, accuracy: 0.5 % of rated output current $\pm 1$ count.				
Indications		GREEN LED's: FINE, MENU, PREV, PROT, REM/LOC, OUT ON/OFF , CV, CC				
		RED LED's: ALARM (OVP, UVP, OTP, FOLD, AC FAIL).				
Function buttons		FINE, MENU, PREV, PROT, REM/LOC, OUT ON/OFF				

\*5: Not including EMI filter inrush current, less than 0.2 ms at cold start Ta = 25 °C.

\*6: At 85~132 V AC or 170~265 V AC, constant load.

\*7: From No-Load to Full-Load, constant input voltage. Measured at the sensing point in Remote Sense.

\*8: Measured with JEITA RC-9131A (1:1) probe.

\*9: From 10 % to 90 % or 90 % to 10 % of Rated Output Voltage, with rated resistive load.

\*10: From 90 % to 10 % of Rated Output Voltage.

\*11: For load voltage change, equal to the unit voltage rating, constant input voltage.

Model	Z	10-20	20-10	36-6	60-3.5	100-2
<b>Programming and readback (RS232/485, USB, Optional: IEEE; LAN)</b>						
Vout programming accuracy		0.05 % of rated output voltage				
Iout programming accuracy (*13)		0.1 % of actual +0.1 % of rated output current				
Vout programming resolution		0.012 % of full scale				
Iout programming resolution		0.012 % of full scale				
Vout readback accuracy		0.05 % of rated output voltage				
Iout readback accuracy (*13)		0.1 % of actual +0.3 % of rated output current				
Vout readback resolution		0.012 % of full scale				
Iout readback resolution		0.012 % of full scale				
<b>Input Characteristics</b>						
Input voltage/freq. (*3)		85~265 V AC continuous, 47~63 Hz, Single-Phase				
Maximum Input current 100/200 V AC (*18)		2.65/1.29	2.61/1.28	2.71/1.34	2.68/1.32	2.54/1.25
Power Factor (Typ)		> 0.99 at 100 V AC , > 0.98 at 200 V AC, 100 % load				
Efficiency (Typ) 100/200 V AC (*4)(*18)	[%]	76/78	77/79	80/82	79/81	
Inrush current (*5)		Less than 15 A / 30 A				
<b>Environmental Conditions</b>						
Operating temperature		0~50 °C, 100 % load.				
Storage temperature		-20~85 °C				
Operating humidity	[%]	20~90 % RH (no condensation).				
Storage humidity	[%]	10~95 % RH (no condensation).				
Altitude		Maximum 3000 m. Derate ambient temp above 2000 m. Operating: Maximum ambient temperature, from 2000 m up to 3000 m Ambient temperature 40 °C.				
<b>Safety/EMC</b>						
Applicable standards:	Safety	UL61010-1, EN61010-1, IEC61010-1. Design to meet UL60950-1, EN60950-1				
	EMC	IEC61326-1 (Built to meet EN55022/EN55024)				
Withstand voltage	Safety	10 ≤ Vout ≤ 36V models: Input-Output & J1, J2, J3, J4, USB, LAN/IEEE/ISOLATED ANALOG: 4242 V DC / 1 min; Input-Ground: 2828 V DC / 1 min. Output & J1, J2, J3, J4, USB, LAN/IEEE/ISOLATED ANALOG-Ground: 1000 V DC / 1 min. 60 V, 100 V models: Input-Output & J1, J2: 4242 V DC / 1 min; Input-J3, J4, USB, LAN/IEEE/ISOLATED Analog: 4242 V DC / 1 min; Input-Ground: 2828 V DC / 1 min. Output & J1, J2 - J3, J4, USB, LAN/IEEE/ISOLATED ANALOG: 1910 V DC / 1 min; Output & J1, J2-Ground: 1380 V DC / 1 min. J3, J4, USB/LAN/IEEE/ISOLATED ANALOG - Ground: 1000 V DC / 1 min;				
Insulation resistance		More than 100 MΩ at 25 °C, 70 % RH.				
Conducted emission		EN55022B, FCC part 15-B, VCCI-B				
Radiated emission		EN55022B, FCC part 15-B, VCCI-B				
<b>Mechanical</b>						
Cooling		Forced air cooling by internal fan.				
Weight	Standard	[kg]	Less than 1.9 kg			
	Wide Body		Less than 2.4 kg. Wide body with Isolated analog or Binding post or IEEE.			
Dimensions (W x H x D)	Standard	[mm]	H: 83, W: 70, D: 350 (excluding bus bars, handles...). (Refer to Outline drawing).			
	Wide Body		H: 83, W: 105, D: 350 (excluding bus bars, handles...). (Refer to Outline drawing).			
Shock			According to: IEC60068-2-64 Less than 20 G, half sine, 11 ms. Unit is unpacked. According to: IEC60068-2-27			

\*12: For 10 V model the ripple is measured at 2 V to rated output voltage and rated output current. For other models, the ripple is measured at 10~100 % of rated output voltage and rated output current.

\*13: The Constant Current programming, readback and monitoring accuracy do not include the warm-up and Load regulation thermal drift.

\*14: Measured with JEITA RC-9131A (1:1) probe.

\*15: For cases where the time interval between each down programming is longer than Td (time delay).

\*16: For cases where the time interval between each down programming is shorter than Td (time delay).

\*17: Td typical (±20 %) Minimum time between consecutive down programming cycles.

\*18: PS with isolated analog option decreases efficiency by 1.5 % and increases input current by 1.5 %

# Specifications Z<sup>+</sup> 400 W

Output Rating		Z	10-40	20-20	36-12	60-7	100-4
Rated output voltage (*1)		[V]	10	20	36	60	100
Rated output current (*2)		[A]	40	20	12	7	4
Rated output power		[W]	400		432	420	400
Constant Voltage Mode							
Max. Line regulation (*6)			0.01 % of rated output voltage +2 mV				
Max. Load regulation (*7)			0.01 % of rated output voltage +2 mV				
Ripple and noise (p-p, 20 MHz) (*8)		[mV]	50				80
Ripple r.m.s. 5 Hz~1 MHz		[mV]	5	6	7	8	
Temperature coefficient		[PPM/°C]	30PPM/°C from rated output voltage, following 30 minutes warm-up.				
Temperature stability			0.02 % of rated Vout over 8 hrs interval following 30 minutes warm-up. Constant line, load & temp.				
Warm-up drift			Less than 0.05 % of rated output voltage +2 mV over 30 minutes following power on.				
Remote sense compensation/wire		[V]	1	2	3	5	
Up-prog. Response time, 0~Vomax. (*9)		[ms]	15	30	50		
Down-prog. response time:	Full load (*9)	[ms]	10	15	30	50	
	Time delay (*17)		210	250	320	380	1200
	No load (*10) (*15)(*17)		40	65	85	100	250
	No load (*10) (*16)(*17)		200	200	290	310	1100
Transient response time		[ms]	Time for output voltage to recover within 0.5 % of its rated output for a load change 10~90 % of rated output current. Output set-point: 10~100 %, Local sense. Less than 1 ms, for models up to and including 100 V				
Hold-up time			15 ms Typical.	16 ms Typical. Rated output power			
Constant Current Mode							
Max. Line regulation (*6)			0.01 % of rated output voltage +2 mA				
Max. Load regulation (*11)			0.01 % of rated output voltage +5 mA				
Load regulation thermal drift			Less than 0.05 % of rated output current over 30 minutes following load change.				
Ripple r.m.s. 5 Hz~1 MHz (*12)		[mA]	70	40	15	8	3
Temperature coefficient		[PPM/°C]	100PPM/°C from rated output current, following 30 minutes warm-up.				
Temperature stability			0.05 % of rated Iout over 8 hrs. interval following 30 minutes warm-up. Constant line, load & temperature.				
Warm-up drift			Less than ± 0.1 % of rated output current over 30 minutes following power on.				
Protective Functions							
Fold-back protection			Output shut-down when power supply change mode from CV to CC or CC to CV. User presetable. Reset by AC input recycle in autostart mode or by OUT button or by rear panel ENABLE, or by communication port.				
Over-voltage protection (OVP)			Inverter Shut down method. Reset by AC input recycle in autostart mode or by OUT button or by rear panel ENABLE, or by communication port.				
Over-voltage trip point		[V]	0.5-12	1~24	2~40	5~66	5~110
Output under voltage limit (UVL)			Preset by front panel or communication port. Prevents from adjusting Vout below limit. Does not affect in analog programming.				
Output under voltage protection (UVP)			Output shut-down when power supply output voltage goes below UVP programming. Reset by AC input recycle in autostart mode or by OUT button or by rear panel ENABLE, or by communication port.				
Over temperature protection			User selectable, latched or non latched.				

\*1: Minimum voltage is guaranteed to maximum 0.1 % of rated output voltage.

\*2: Minimum current is guaranteed to maximum 0.2 % of rated output current.

\*3: For cases where conformance to various safety standards (UL, IEC, etc...) is required, to be described as 100-240 V AC (50/60Hz).

Analog Programming and Monitoring		10-40	20-20	36-12	60-7	100-4
Vout voltage programming		0~100 %, 0~5 V or 0~10 V, user selectable. Accuracy and linearity: ± 0.5 % of rated Vout.				
Iout voltage programming (*13)		0~100 %, 0~5 V or 0~10 V, user selectable. Accuracy and linearity: ± 1 % of rated Iout.				
Vout resistor programming		0~100 %, 0~5/10 kΩ full scale, user selectable. Accuracy and linearity: ± 1 % of rated Vout.				
Iout resistor programming (*13)		0~100 %, 0~5/10 kΩ full scale, user selectable. Accuracy and linearity: ± 1.5 % of rated Iout.				
Shut-off (SO) control		By electrical Voltage: 0~0.6 V/2~15 V or dry contact, user selectable logic.				
Output current monitor (*13)		0~5 V or 0~10 V, user selectable. Accuracy: ± 1 %.				
Output voltage monitor		0~5 V or 0~10 V, user selectable. Accuracy: ± 1 %.				
Power supply OK signal		4~5 V-OK, 0V-Fail. 500 Ω series resistance.				
Parallel operation		Possible, up to 6 units in master/slave mode with single wire current balance connection.				
Series operation		2 identical units (with external diodes).				
CV/CC indicator		Open collector. CC mode: On, CV mode: Off. Maximum voltage: 30 V, maximum sink current: 10 mA				
Interlock (ILC) control		Enables/Disables the PS output by dry contact (Short: On, Open: Off, Source current: less than 0.5 mA). Ena/Dis is activated by front panel.				
Local/Remote mode Control		By electrical signal or Open/Short: 0~0.6 V or short: Remote, 2~15 V or open: Local				
Local/Remote mode Indicator		Open collector (shunted by 36 V zener). On (0~0.6 V, 10 mA sink current max.)-Remote. Off-Local (30 V max.).				
Trigger out		Maximum low level output = 0.8 V, Minimum high level output = 2 V, maximum source current = 8 mA, minimum pulse = 10 μs ~ 20 μs.				
Trigger in		Maximum low level input voltage = 0.8 V, minimum high level input voltage = 2.0 V, Maximum sink current = 8 mA, 10 μs minimum positive edge trigger				
Programmed signal 1		Open collector, maximum voltage 25 V, maximum sink current 100 mA. (Shunted by 27 V zener)				
Programmed signal 2		Open collector, maximum voltage 25 V, maximum sink current 100 mA. (Shunted by 27 V zener)				
<b>Front Panel</b>						
Control functions		Multiple options with 2 Encoders				
		Vout/Iout manual adjust				
		OVP/UVL/UVP manual adjust				
		Protection Functions - OVP, UVL,UVP, Fold-back, OCP, INT, SO				
		Communication Functions - Selection of LAN, IEEE, RS232, RS485, USB				
		Communication Functions - Selection of Baud Rate, Address				
		Analog Control Functions - Selection Voltage/resistive programming, 5 V/10 V, 5 K/10 K programming				
		Analog Control Functions - Selection of Voltage/Current Monitoring 5 V/10 V, Output ON/OFF, Front Panel Lock.				
Display		Vout: 4 digits, accuracy: 0.5 % of rated output voltage ± 1 count.				
		Iout: 4 digits, accuracy: 0.5 % of rated output current ± 1 count.				
Indications		GREEN LED's: FINE, MENU, PREV, PROT, REM/LOC, OUT ON/OFF , CV, CC				
		RED LED's: ALARM (OVP, UVP, OTP, FOLD, AC FAIL).				
Functions buttons		FINE, MENU, PREV, PROT, REM/LOC, OUT ON/OFF				

\*4: Ta = 25 °C with rated output power.

\*5: Not including EMI filter inrush current, less than 0.2 ms.

\*6: At 85~132 V AC or 170~265 V AC, constant load.

\*7: From No-Load to Full-Load, constant input voltage. Measured at the sensing point in Remote Sense.

\*8: Measured with JEITA RC-9131A (1:1) probe.

\*9: From 10 % to 90 % or 90 % to 10% of Rated Output Voltage, with rated resistive load.

\*10: From 90 % to 10 % of Rated Output Voltage.

\*11: For load voltage change, equal to the unit voltage rating, constant input voltage.

\*12: For 10 V model the ripple is measured at 2 V to rated output voltage and rated output current. For other models, the ripple is measured at 10~100 % of rated output voltage and rated output current.

Model	Z	10-40	20-20	36-12	60-7	100-4
<b>Programming and readback (RS232/485, USB, Optional: IEEE; LAN)</b>						
Vout programming accuracy		0.05 % of rated output voltage				
Iout programming accuracy (*13)		0.1 % actual + 0.1 % of rated output current				
Vout programming resolution		0.012 % of full scale				
Iout programming resolution		0.012 % of full scale				
Vout readback accuracy		0.05 % of rated output voltage				
Iout readback accuracy (*13)		0.1 % of actual + 0.3 % rated output current				
Vout readback resolution		0.012 % of full scale				
Iout readback resolution		0.012 % of full scale				
<b>Input Characteristics</b>						
Input voltage/freq. (*3)		85~265 V AC continuous, 47~63 Hz, Single-Phase				
Maximum Input current 100/200 V AC (*18)		5.05/2.5	4.98/2.45	5.25/2.57	5.10/2.50	4.80/2.37
Power Factor (Typ)		0.99 at 100/200 V AC, 100 % load				
Efficiency (Typ) 100/200 V AC (*4) (*18)	[%]	80/82	81/83	83/85	83/85	84/86
Inrush current (*5)		Less than 25 A				
<b>Environmental Conditions</b>						
Operating temperature		0~50 °C, 100 % load.				
Storage temperature		-20~85 °C				
Operating humidity	[%]	20~90 % RH (no condensation).				
Storage humidity	[%]	10~95 % RH (no condensation).				
Altitude		Maximum 3000 m. Derate ambient temp above 2000 m. Operating: Maximum ambient temperature, from 2000 m up to 3000 m Ambient temperature 40 °C.				
<b>Safety/EMC</b>						
Applicable standards:	Safety	UL61010-1, EN61010-1, IEC61010-1. Design to meet UL60950-1, EN60950-1				
	EMC	IEC61326-1 (Built to meet EN55022/EN55024)				
Withstand voltage	Safety	10 ≤ Vout ≤ 36V models: Input-Output & J1, J2, J3, J4, USB, LAN/IEEE/ISOLATED ANALOG: 4242 V DC / 1 min; Input-Ground: 2828 V DC / 1 min. Output & J1, J2, J3, J4, USB, LAN/IEEE/ISOLATED ANALOG-Ground: 1000 V DC / 1 min. 60 V, 100 V models: Input-Output & J1, J2: 4242 V DC / 1 min; Input-J3, J4, USB, LAN/IEEE/ISOLATED Analog: 4242 V DC / 1 min; Input-Ground: 2828 V DC / 1 min. Output & J1, J2 - J3, J4, USB, LAN/IEEE/ISOLATED ANALOG: 1910 V DC / 1 min; Output & J1, J2-Ground: 1380 V DC / 1 min. J3, J4, USB/LAN/IEEE/ISOLATED ANALOG - Ground: 1000 V DC / 1 min;				
Insulation resistance		More than 100 MΩ at 25 °C, 70 % RH.				
Conducted emission		EN55022B, FCC part 15-B, VCCI-B				
Radiated emission		EN55022B, FCC part 15-B, VCCI-B				
<b>Mechanical</b>						
Cooling		Forced air cooling by internal fan.				
Weight	Standard	[kg]	Less than 1.9 kg			
	Wide Body		Less than 2.4 kg. Wide body with Isolated analog or Binding post or IEEE.			
Dimensions (W x H x D)	Standard	[mm]	H: 83, W: 70, D: 350 (excluding bus bars, handles...) (Refer to Outline drawing).			
	Wide Body		H: 83, W: 105, D: 350 (excluding bus bars, handles...) (Refer to Outline drawing).			
Shock			According to: IEC60068-2-64 Less than 20 G, half sine, 11 ms. Unit is unpacked. According to: IEC60068-2-27			

\*13: The Constant Current programming, readback and monitoring accuracy do not include the warm-up and Load regulation thermal drift.

\*14: Measured with JEITA RC-9131A (1:1) probe.

\*15: For cases where the time interval between each down programming is longer than Td (time delay).

\*16: For cases where the time interval between each down programming is shorter than Td (time delay).

\*17: Td typical (±20 %) Minimum time between consecutive down programming cycles.

\*18: PS with isolated analog option decreases efficiency by 0.5 % and increases input current by 0.5 %

# Specifications Z<sup>+</sup> 600 W

Output Rating		Z	10-60	20-30	36-18	60-10	100-6
Rated output voltage (*1)		[V]	10	20	36	60	100
Rated output current (*2)		[A]	60	30	18	10	6
Rated output power		[W]	600		648	600	
Constant Voltage Mode							
Max. Line regulation (*6)			0.01 % of rated output voltage +2 mV				
Max. Load regulation (*7)			0.01 % of rated output voltage +2 mV				
Ripple and noise (p-p, 20 MHz) (*8)		[mV]	75				100
Ripple r.m.s. 5 Hz~1 MHz		[mV]	6.25				10
Temperature coefficient		[PPM/°C]	30PPM/°C from rated output voltage, following 30 minutes warm-up.				
Temperature stability			0.02 % of rated Vout over 8 hrs interval following 30 minutes warm-up. Constant line, load & temp.				
Warm-up drift			Less than 0.05 % of rated output voltage +2 mV over 30 minutes following power on.				
Remote sense compensation/wire		[V]	1		2	3	5
Up-prog. Response time, 0~Vomax. (*9)		[ms]	15	30	50		
Down-prog. response time:	Full load (*9)	[ms]	10	30	50		
	Time delay (*17)		260	310	400	475	1500
	No load (*10) (*15) (*17)		40	80	100	120	250
	No load (*10) (*16) (*17)		190	200	290	310	900
Transient response time		[ms]	Time for output voltage to recover within 0.5 % of its rated output for a load change 10~90 % of rated output current. Output set-point: 10~100 %, Local sense. Less than 1 ms, for models up to and including 100 V				
Hold-up time			16 ms Typical. Rated output power				
Constant Current Mode							
Max. Line regulation (*6)			0.01 % of rated output voltage +2 mA				
Max. Load regulation (*11)			0.01 % of rated output voltage +5 mA				
Load regulation thermal drift			Less than 0.05 % of rated output current over 30 minutes following load change.				
Ripple r.m.s. 5 Hz~1 MHz (*12)		[mA]	75	45	22	12	4.5
Temperature coefficient		[PPM/°C]	100PPM/°C from rated output current, following 30 minutes warm-up.				
Temperature stability			0.05 % of rated Iout over 8 hrs. interval following 30 minutes warm-up. Constant line, load & temperature.				
Warm-up drift			Less than ± 0.1 % of rated output current over 30 minutes following power on.				
Protective Functions							
Fold-back protection			Output shut-down when power supply change mode from CV to CC or CC to CV. User presetable. Reset by AC input recycle in autostart mode or by OUT button or by rear panel ENABLE, or by communication port.				
Over-voltage protection (OVP)			Inverter Shut down method. Reset by AC input recycle in autostart mode or by OUT button or by rear panel ENABLE, or by communication port.				
Over-voltage trip point		[V]	0.5-12	1~24	2~40	5~66	5~110
Output under voltage limit (UVL)			Preset by front panel or communication port. Prevents from adjusting Vout below limit. Does not affect in analog programming.				
Output under voltage protection (UVP)			Output shut-down when power supply output voltage goes below UVP programming. Reset by AC input recycle in autostart mode or by OUT button or by rear panel ENABLE, or by communication port.				
Over temperature protection			User selectable, latched or non latched.				

\*1: Minimum voltage is guaranteed to maximum 0.1 % of rated output voltage.  
\*2: Minimum current is guaranteed to maximum 0.2 % of rated output current.

\*3: For cases where conformance to various safety standards (UL, IEC, etc...) is required, to be described as 100-240 V AC (50/60Hz).  
\*4: Ta = 25 °C with rated output power.

Analog Programming and Monitoring		10-60	20-30	36-18	60-10	100-6
Vout voltage programming		0~100 %, 0~5 V or 0~10 V, user selectable. Accuracy and linearity: $\pm 0.5\%$ of rated Vout.				
Iout voltage programming (*13)		0~100 %, 0~5 V or 0~10 V, user selectable. Accuracy and linearity: $\pm 1\%$ of rated Iout.				
Vout resistor programming		0~100 %, 0~5/10 k $\Omega$ full scale, user selectable. Accuracy and linearity: $\pm 1\%$ of rated Vout.				
Iout resistor programming (*13)		0~100 %, 0~5/10 k $\Omega$ full scale, user selectable. Accuracy and linearity: $\pm 1.5\%$ of rated Iout.				
Shut-off (SO) control		By electrical Voltage: 0~0.6 V/2~15 V or dry contact, user selectable logic.				
Output current monitor (*13)		0~5 V or 0~10 V, user selectable. Accuracy: $\pm 1\%$ .				
Output voltage monitor		0~5 V or 0~10 V, user selectable. Accuracy: $\pm 1\%$ .				
Power supply OK signal		4~5 V-OK, 0V-Fail. 500 $\Omega$ series resistance.				
Parallel operation		Possible, up to 6 units in master/slave mode with single wire current balance connection.				
Series operation		2 identical units (with external diodes).				
CV/CC indicator		Open collector. CC mode: On, CV mode: Off. Maximum voltage: 30 V, maximum sink current: 10 mA				
Interlock (ILC) control		Enables/Disables the PS output by dry contact (Short: On, Open: Off, Source current: less than 0.5 mA). Ena/Dis is activated by front panel.				
Local/Remote mode Control		By electrical signal or Open/Short: 0~0.6 V or short: Remote, 2~15 V or open: Local				
Local/Remote mode Indicator		Open collector (shunted by 36 V zener). On (0~0.6 V, 10 mA sink current max.) Remote. Off-Local (30 V max.).				
Trigger out		Maximum low level output = 0.8 V, minimum high level output = 2 V, maximum source current = 8 mA, minimum pulse = 10 $\mu$ s ~ 20 $\mu$ s.				
Trigger in		Maximum low level input voltage = 0.8 V, minimum high level input voltage = 2.0 V, maximum sink current = 8 mA, 10 $\mu$ s minimum positive edge trigger				
Programmed signal 1		Open collector, maximum voltage 25 V, maximum sink current 100 mA. (Shunted by 27 V zener)				
Programmed signal 2		Open collector, maximum voltage 25 V, maximum sink current 100 mA. (Shunted by 27 V zener)				
<b>Front Panel</b>						
Control functions		Multiple options with 2 Encoders				
		Vout/Iout manual adjust				
		OVP/UVL/UVP manual adjust				
		Protection Functions - OVP, UVL,UVP, Fold-back, OCP, INT, SO				
		Communication Functions - Selection of LAN, IEEE, RS232, RS485, USB				
		Communication Functions - Selection of Baud Rate, Address				
		Analog Control Functions - Selection Voltage/resistive programming, 5 V/10 V, 5 K/10 K programming				
		Analog Control Functions - Selection of Voltage/Current Monitoring 5 V/10 V, Output ON/OFF, Front Panel Lock.				
Display		Vout: 4 digits, accuracy: 0.5 % of rated output voltage $\pm 1$ count.				
		Iout: 4 digits, accuracy: 0.5 % of rated output current $\pm 1$ count.				
Indications		GREEN LED's: FINE, MENU, PREV, PROT, REM/LOC, OUT ON/OFF , CV, CC				
		RED LED's: ALARM (OVP, UVP, OTP, FOLD, AC FAIL).				
Functions buttons		FINE, MENU, PREV, PROT, REM/LOC, OUT ON/OFF				

\*5: Not including EMI filter inrush current, less than 0.2 ms at cold start Ta = 25 °C.

\*6: At 85~132 V AC or 170~265 V AC, constant load.

\*7: From No-Load to Full-Load, constant input voltage. Measured at the sensing point in Remote Sense.

\*8: Measured with JEITA RC-9131A (1:1) probe.

\*9: From 10 % to 90 % or 90 % to 10 % of Rated Output Voltage, with rated resistive load.

\*10: From 90 % to 10 % of Rated Output Voltage.

\*11: For load voltage change, equal to the unit voltage rating, constant input voltage.

Model	Z	10-60	20-30	36-18	60-10	100-6
<b>Programming and readback (RS232/485, USB, Optional: IEEE; LAN)</b>						
Vout programming accuracy		0.05 % of rated output voltage				
Iout programming accuracy (*13)		0.1 % of actual +0.1 % rated output current				
Vout programming resolution		0.012 % of full scale				
Iout programming resolution		0.012 % of full scale				
Vout readback accuracy		0.05 % of rated output voltage				
Iout readback accuracy (*13)		0.1 % of actual +0.3 % rated output current				
Vout readback resolution		0.012 % of full scale				
Iout readback resolution		0.012 % of full scale				
<b>Input Characteristics</b>						
Input voltage/freq. (*3)		85~265 V AC continuous, 47~63 Hz, Single-Phase				
Maximum Input current 100/200 V AC (*18)		7.4/3.6	7.24/3.53	7.73/3.77	7.15/3.5	7.15/3.5
Power Factor (Typ)		0.99 at 100/200 V AC, 100 % load				
Efficiency (Typ) 100/200VAC (*4) (*18)	[%]	82/84	84/86	85/87	85/87	85/87
Inrush current (*5)		Less than 25 A				
<b>Environmental Conditions</b>						
Operating temperature		0~50 °C, 100 % load.				
Storage temperature		-20~85 °C				
Operating humidity	[%]	20~90 % RH (no condensation).				
Storage humidity	[%]	10~95 % RH (no condensation).				
Altitude		Maximum 3000 m. Derate ambient temp above 2000 m. Operating: Maximum ambient temperature, from 2000 m up to 3000 m Ambient temperature 40 °C.				
<b>Safety/EMC</b>						
Applicable standards:	Safety	UL61010-1, EN61010-1, IEC61010-1. Design to meet UL60950-1, EN60950-1				
	EMC	IEC61326-1 (Built to meet EN55022/EN55024)				
Withstand voltage	Safety	10 ≤ Vout ≤ 36V models: Input-Output & J1, J2, J3, J4, USB, LAN/IEEE/ISOLATED ANALOG: 4242 V DC / 1 min; Input-Ground: 2828 V DC / 1 min. Output & J1, J2, J3, J4, USB, LAN/IEEE/ISOLATED ANALOG-Ground: 1000 V DC / 1 min. 60 V, 100 V models: Input-Output & J1, J2: 4242 V DC / 1 min; Input-J3, J4, USB, LAN/IEEE/ISOLATED Analog: 4242 V DC / 1 min; Input-Ground: 2828 V DC / 1 min. Output & J1, J2 - J3, J4, USB, LAN/IEEE/ISOLATED ANALOG: 1910 V DC / 1 min; Output & J1, J2-Ground: 1380 V DC / 1 min. J3, J4, USB/LAN/IEEE/ISOLATED ANALOG - Ground: 1000 V DC / 1 min;				
Insulation resistance		More than 100 MΩ at 25 °C, 70 % RH.				
Conducted emission		EN55022B, FCC part 15-B, VCCI-B				
Radiated emission		EN55022B, FCC part 15-B, VCCI-B				
<b>Mechanical</b>						
Cooling		Forced air cooling by internal fan.				
Weight	Standard	[kg]	Less than 2.5 kg			
	Wide Body		Less than 3.0 kg. Wide body with Isolated analog or Binding post or IEEE.			
Dimensions (W x H x D)	Standard	[mm]	H: 83, W: 70, D: 350 (excluding bus bars, handles...). (Refer to Outline drawing).			
	Wide Body		H: 83, W: 105, D: 350 (excluding bus bars, handles...). (Refer to Outline drawing).			
Shock			According to: IEC60068-2-64 Less than 20 G, half sine, 11 ms. Unit is unpacked. According to: IEC60068-2-27			

\*12: For 10 V model the ripple is measured at 2 V to rated output voltage and rated output current. For other models, the ripple is measured at 10~100 % of rated output voltage and rated output current.

\*13: The Constant Current programming, readback and monitoring accuracy do not include the warm-up and Load regulation thermal drift.

\*14: Measured with JEITA RC-9131A (1:1) probe.

\*15: For cases where the time interval between each down programming is longer than Td (time delay).

\*16: For cases where the time interval between each down programming is shorter than Td (time delay).

\*17: Td typical (±20 %) Minimum time between consecutive down programming cycles.

\*18: PS with isolated analog option decreases efficiency by 0.5 % and increases input current by 0.5 %

# Specifications Z<sup>+</sup> 800 W

Output Rating		Z	10-75	20-40	36-24	60-14	100-8
Rated output voltage (*1)		[V]	10	20	36	60	100
Rated output current (*2)		[A]	75	40	24	14	8
Rated output power		[W]	750	800	864	840	800
Constant Voltage Mode							
Max. Line regulation (*6)			0.01 % of rated output voltage +2 mV				
Max. Load regulation (*7)			0.01 % of rated output voltage +2 mV				
Ripple and noise (p-p, 20 MHz) (*8)		[mV]	75				100
Ripple r.m.s. 5 Hz~1 MHz		[mV]	6.25				10
Temperature coefficient		[PPM/°C]	30PPM/°C from rated output voltage, following 30 minutes warm-up.				
Temperature stability			0.02 % of rated Vout over 8 hrs interval following 30 minutes warm-up. Constant line, load & temp.				
Warm-up drift			Less than 0.05 % of rated output voltage +2 mV over 30 minutes following power on.				
Remote sense compensation/wire		[V]	1		2	3	5
Up-prog. Response time, 0~Vomax. (*9)		[ms]	15	30		50	
Down-prog. response time:	Full load (*9)	[ms]	10	30		50	
	Time delay (*17)		260	310	400	475	1500
	No load (*10) (*15)(*17)		35	65	85	100	250
	No load (*10) (*16)(*17)		190	200	290	310	900
Transient response time		[ms]	Time for output voltage to recover within 0.5 % of its rated output for a load change 10~90 % of rated output current. Output set-point: 10~100 %, Local sense. Less than 1 ms, for models up to and including 100 V				
Hold-up time			16 ms Typical. Rated output power				
Constant Current Mode							
Max. Line regulation (*6)			0.01 % of rated output voltage +2 mA				
Max. Load regulation (*11)			0.01 % of rated output voltage +5 mA				
Load regulation thermal drift			Less than 0.05 % of rated output current over 30 minutes following load change.				
Ripple r.m.s. 5 Hz~1 MHz (*12)		[mA]	75	45	22	12	4.5
Temperature coefficient		[PPM/°C]	100PPM/°C from rated output current, following 30 minutes warm-up.				
Temperature stability			0.05 % of rated Iout over 8 hrs. interval following 30 minutes warm-up. Constant line, load & temperature.				
Warm-up drift			Less than ± 0.1 % of rated output current over 30 minutes following power on.				
Protective Functions							
Fold-back protection			Output shut-down when power supply change mode from CV to CC or CC to CV. User presetable. Reset by AC input recycle in autostart mode or by OUT button or by rear panel ENABLE, or by communication port.				
Over-voltage protection (OVP)			Inverter Shut down method. Reset by AC input recycle in autostart mode or by OUT button or by rear panel ENABLE, or by communication port.				
Over-voltage trip point		[V]	0.5-12	1~24	2~40	5~66	5~110
Output under voltage limit (UVL)			Preset by front panel or communication port. Prevents from adjusting Vout below limit. Does not affect in analog programming.				
Output under voltage protection (UVP)			Output shut-down when power supply output voltage goes below UVP programming. Reset by AC input recycle in autostart mode or by OUT button or by rear panel ENABLE, or by communication port.				
Over temperature protection			User selectable, latched or non latched.				

\*1: Minimum voltage is guaranteed to maximum 0.1 % of rated output voltage.

\*2: Minimum current is guaranteed to maximum 0.2 % of rated output current.

\*3: For cases where conformance to various safety standards (UL, IEC, etc...) is required, to be described as 100-240 V AC (50/60Hz).

\*4: Ta = 25 °C with rated output power.

\*5: Not including EMI filter inrush current, less than 0.2 ms.

Analog Programming and Monitoring		10-75	20-40	36-24	60-14	100-8
Vout voltage programming		0~100 %, 0~5 V or 0~10 V, user selectable. Accuracy and linearity: ± 0.5 % of rated Vout.				
Iout voltage programming (*13)		0~100 %, 0~5 V or 0~10 V, user selectable. Accuracy and linearity: ± 1 % of rated Iout.				
Vout resistor programming		0~100 %, 0~5/10 kΩ full scale, user selectable. Accuracy and linearity: ± 1 % of rated Vout.				
Iout resistor programming (*13)		0~100 %, 0~5/10 kΩ full scale, user selectable. Accuracy and linearity: ± 1.5 % of rated Iout.				
Shut-off (SO) control		By electrical Voltage: 0~0.6 V/2~15 V or dry contact, user selectable logic.				
Output current monitor (*13)		0~5 V or 0~10 V, user selectable. Accuracy: ± 1 %.				
Output voltage monitor		0~5 V or 0~10 V, user selectable. Accuracy: ± 1 %.				
Power supply OK signal		4~5 V-OK, 0V-Fail. 500 Ω series resistance.				
Parallel operation		Possible, up to 6 units in master/slave mode with single wire current balance connection.				
Series operation		2 identical units (with external diodes).				
CV/CC indicator		Open collector. CC mode: On, CV mode: Off. Maximum voltage: 30 V, maximum sink current: 10 mA				
Interlock (ILC) control		Enables/Disables the PS output by dry contact (Short: On, Open: Off, Source current: less than 0.5 mA). Ena/Dis is activated by front panel.				
Local/Remote mode Control		By electrical signal or Open/Short: 0~0.6 V or short: Remote, 2~15 V or open: Local				
Local/Remote mode Indicator		Open collector (shunted by 36 V zener). On (0~0.6 V, 10 mA sink current max.)-Remote. Off-Local (30 V max.).				
Trigger out		Maximum low level output = 0.8 V, minimum high level output = 2 V, maximum source current = 8 mA, minimum pulse = 10 μs ~ 20 μs.				
Trigger in		Maximum low level input voltage = 0.8 V, minimum high level input voltage = 2.0 V, maximum sink current = 8 mA, 10 μs minimum positive edge trigger				
Programmed signal 1		Open collector, maximum voltage 25 V, maximum sink current 100 mA. (Shunted by 27 V zener)				
Programmed signal 2		Open collector, maximum voltage 25 V, maximum sink current 100 mA. (Shunted by 27 V zener)				
<b>Front Panel</b>						
Control functions		Multiple options with 2 Encoders				
		Vout/Iout manual adjust				
		OVP/UVL/UVP manual adjust				
		Protection Functions - OVP, UVL,UVP, Fold-back, OCP, INT, SO				
		Communication Functions - Selection of LAN, IEEE, RS232, RS485, USB				
		Communication Functions - Selection of Baud Rate, Address				
		Analog Control Functions - Selection Voltage/resistive programming, 5 V/10 V, 5 K/10 K programming				
		Analog Control Functions - Selection of Voltage/Current Monitoring 5 V/10 V, Output ON/OFF, Front Panel Lock.				
Display		Vout: 4 digits, accuracy: 0.5 % of rated output voltage ± 1 count.				
		Iout: 4 digits, accuracy: 0.5 % of rated output current ± 1 count.				
Indications		GREEN LED's: FINE, MENU, PREV, PROT, REM/LOC, OUT ON/OFF , CV, CC				
		RED LED's: ALARM (OVP, UVP, OTP, FOLD, AC FAIL).				
Function buttons		FINE, MENU, PREV, PROT, REM/LOC, OUT ON/OFF				

\*6: At 85~132 V AC or 170~265 V AC, constant load.  
 \*7: From No-Load to Full-Load, constant input voltage. Measured at the sensing point in Remote Sense.  
 \*8: Measured with JEITA RC-9131A (1:1) probe.

\*9: From 10 % to 90 % or 90 % to 10% of Rated Output Voltage, with rated resistive load.  
 \*10: From 90 % to 10 % of Rated Output Voltage.  
 \*11: For load voltage change, equal to the unit voltage rating, constant input voltage.

Model	Z	10-75	20-40	36-24	60-14	100-8
<b>Programming and readback (RS232/485, USB, Optional: IEEE; LAN)</b>						
Vout programming accuracy		0.05 % of rated output voltage				
Iout programming accuracy (*13)		0.1 % of rated output current				
Vout programming resolution		0.012 % of full scale				
Iout programming resolution		0.012 % of full scale				
Vout readback accuracy		0.05 % of rated output voltage				
Iout readback accuracy (*13)		0.1 % of rated output current				
Vout readback resolution		0.012 % of full scale				
Iout readback resolution		0.012 % of full scale				
<b>Input Characteristics</b>						
Input voltage/freq. (*3)		85~265 V AC continuous, 47~63 Hz, Single-Phase				
Maximum Input current 100/200 V AC (*18)		9.25/4.50	9.65/4.70	10.30/5.02	10.00/4.90	9.5/4.65
Power Factor (Typ)		0.99 at 100/200 V AC, 100 % load				
Efficiency (Typ) 100/200 V AC (*4) (*18)	[%]	80/82	82/84	84/85	83/85	84/86
Inrush current (*5)		Less than 25 A				
<b>Environmental Conditions</b>						
Operating temperature		0~50 °C, 100 % load.				
Storage temperature		-20~85 °C				
Operating humidity	[%]	20~90 % RH (no condensation).				
Storage humidity	[%]	10~95 % RH (no condensation).				
Altitude		Maximum 3000 m. Derate ambient temp above 2000 m. Operating: Maximum ambient temperature, from 2000 m up to 3000 m Ambient temperature 40 °C.				
<b>Safety/EMC</b>						
Applicable standards:	Safety	UL61010-1, EN61010-1, IEC61010-1. Design to meet UL60950-1, EN60950-1				
	EMC	IEC61326-1 (Built to meet EN55022/EN55024)				
Withstand voltage	Safety	USB, LAN/IEEE/ISOLATED ANALOG: 4242 V DC / 1 min; Input-Ground: 2828 V DC / 1 min. Output & J1, J2, J3, J4, USB, LAN/IEEE/ISOLATED ANALOG-Ground: 1000 V DC / 1 min. 60 V, 100 V models: Input-Output & J1, J2: 4242 V DC / 1 min; Input-J3, J4, USB, LAN/IEEE/ISOLATED Analog: 4242 V DC / 1 min; Input-Ground: 2828 V DC / 1 min. Output & J1, J2 - J3, J4, USB, LAN/IEEE/ISOLATED ANALOG:1910 V DC / 1 min; Output & J1, J2-Ground: 1380 V DC / 1 min. J3, J4, USB/LAN/IEEE/ISOLATED ANALOG - Ground: 1000 V DC / 1 min;				
Insulation resistance		More than 100 MΩ at 25 °C, 70 % RH.				
Conducted emission		EN55022B, FCC part 15-B, VCCI-B				
Radiated emission		EN55022B, FCC part 15-B, VCCI-B				
<b>Mechanical</b>						
Cooling		Forced air cooling by internal fan.				
Weight	Standard	[kg]	Less than 2.5 kg			
	Wide Body		Less than 3.0 kg. Wide body with Isolated analog or Binding post or IEEE.			
Dimensions (W x H x D)	Standard	[mm]	H: 83, W: 70, D: 350 (excluding bus bars, handles...). (Refer to Outline drawing).			
	Wide Body		H: 83, W: 105, D: 350 (excluding bus bars, handles...). (Refer to Outline drawing).			
Shock			According to: IEC60068-2-64 Less than 20 G, half sine, 11 ms. Unit is unpacked. According to: IEC600068-2-27			

\*12: For 10 V model the ripple is measured at 2 V to rated output voltage and rated output current. For other models, the ripple is measured at 10~100 % of rated output voltage and rated output current.

\*13: The Constant Current programming, readback and monitoring accuracy do not include the warm-up and Load regulation thermal drift.

\*14: Measured with JEITA RC-9131A (1:1) probe.

\*15: For cases where the time interval between each down programming is longer than Td (time delay).

\*16: For cases where the time interval between each down programming is shorter than Td (time delay).

\*17: Td typical (±20 %) Minimum time between consecutive down programming cycles.

\*18: PS with isolated analog option decreases efficiency by 0.5 % and increases input current by 0.5 %

# Outline drawings Z<sup>+</sup> 200/400/600/800 W

## Standard

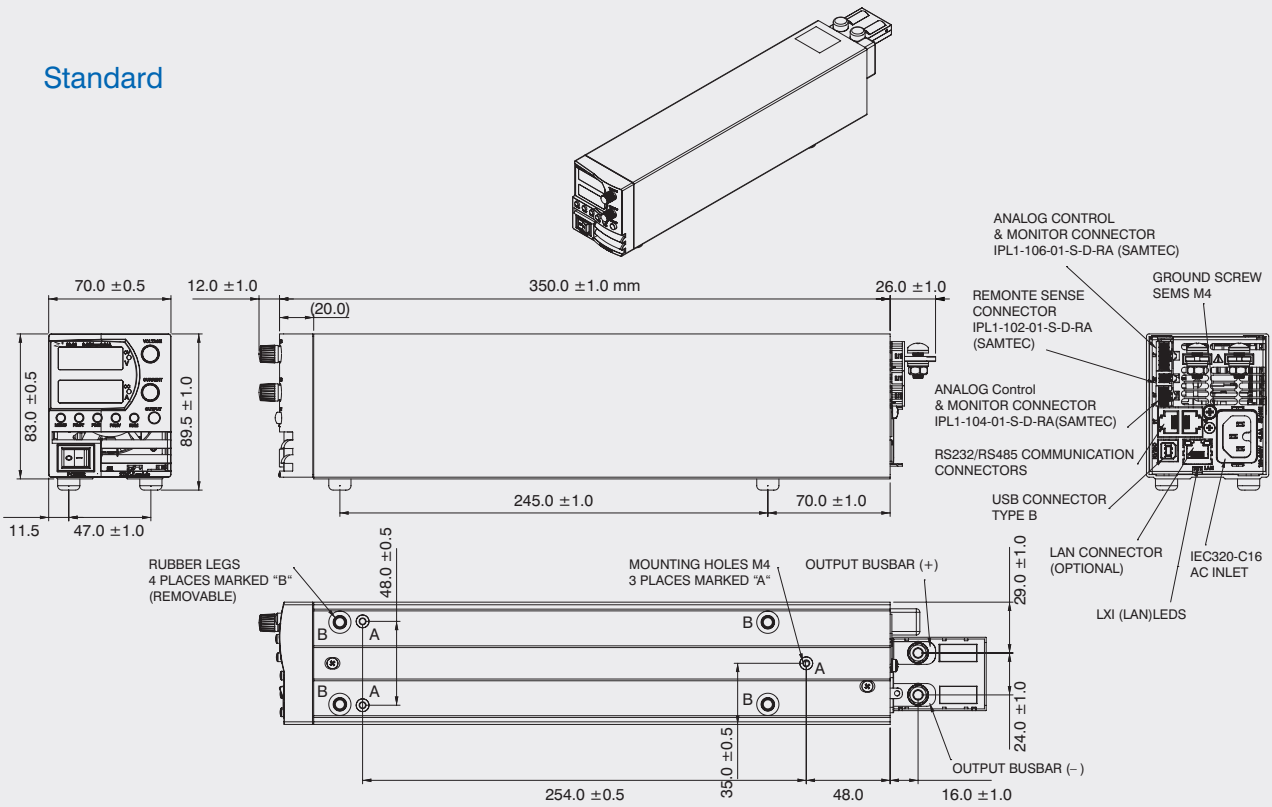

## Wide Body

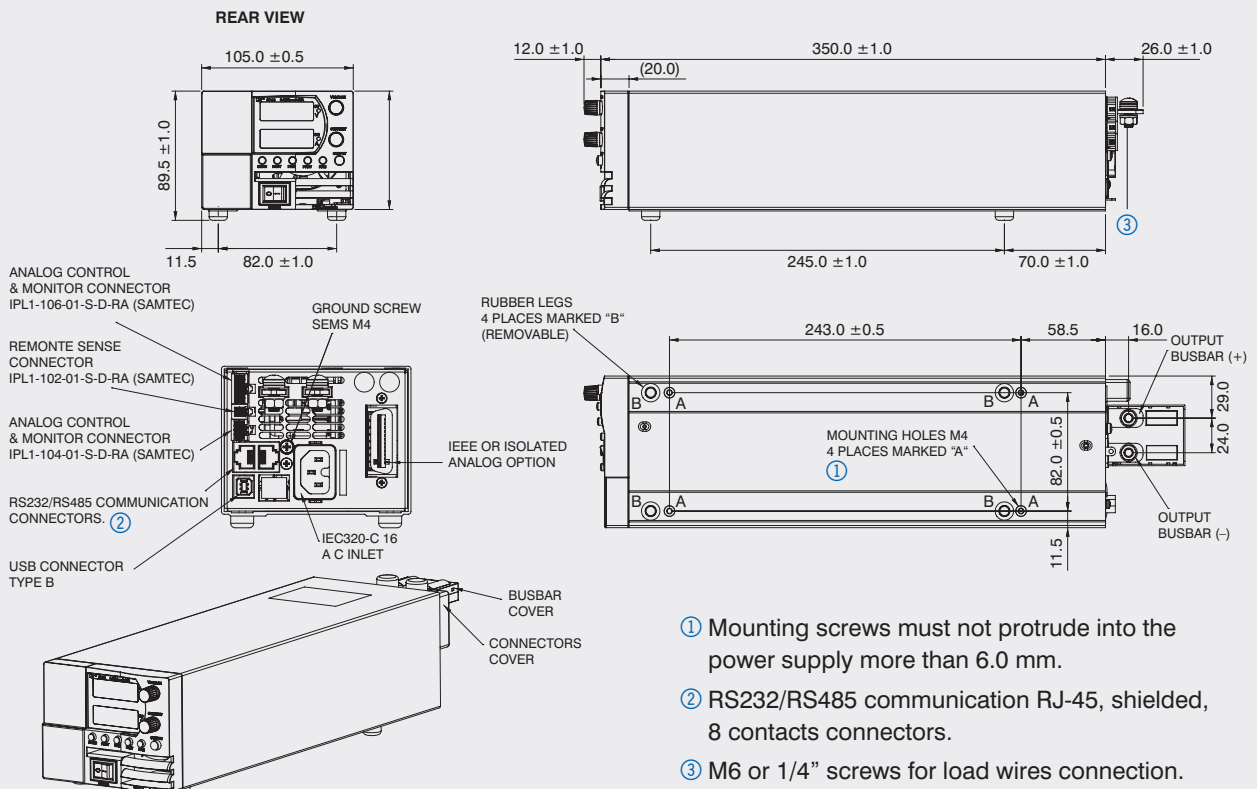

① Mounting screws must not protrude into the power supply more than 6.0 mm.

② RS232/RS485 communication RJ-45, shielded, 8 contacts connectors.

③ M6 or 1/4" screws for load wires connection.

## Front Panel Output Jacks

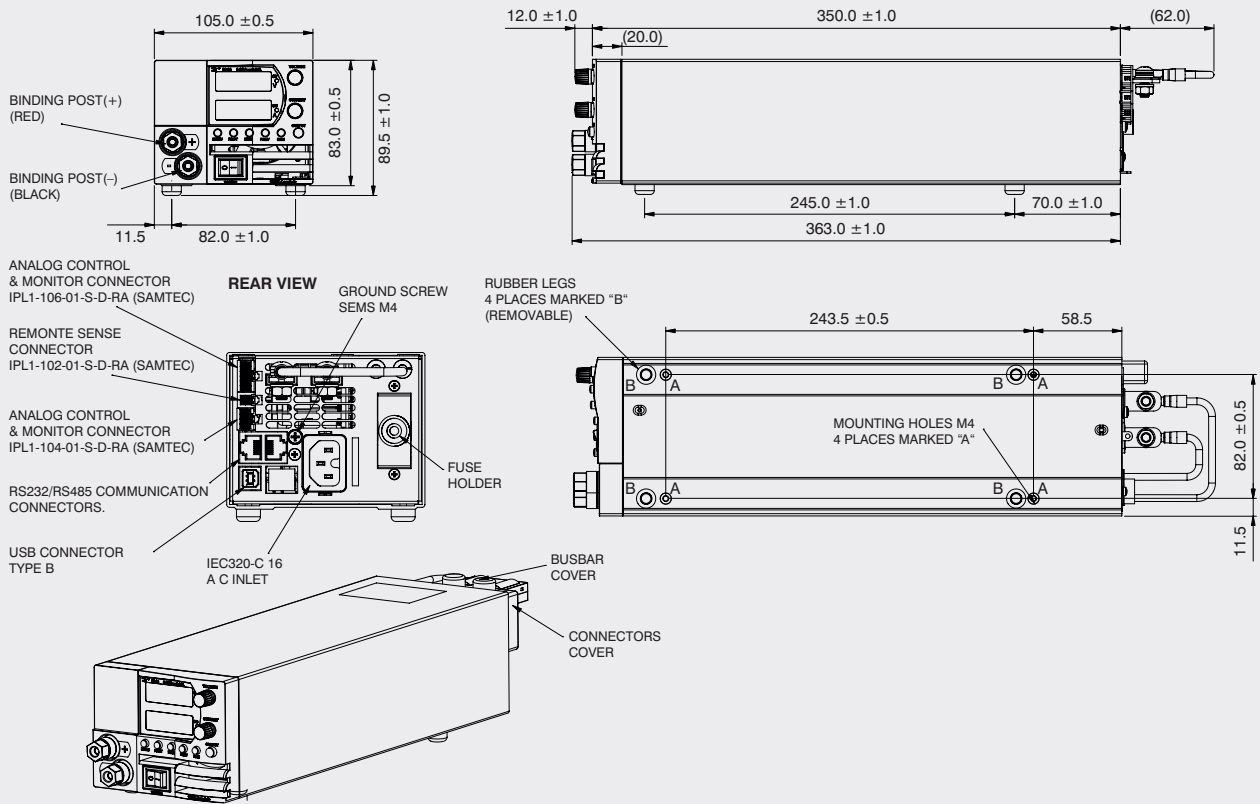

## 19" Rack Housing

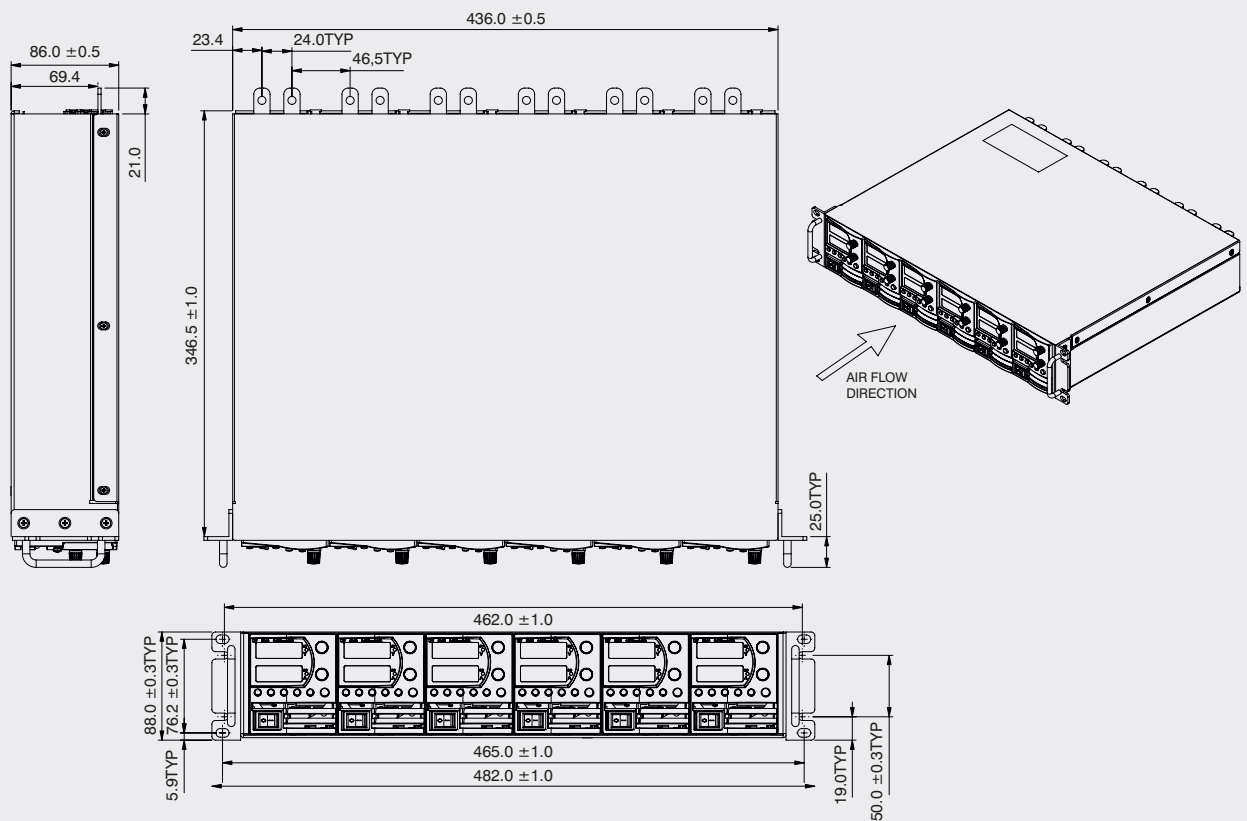

# Z<sup>+</sup> Standard Configurations

## Benchtop Power Supply

### Parallel operation – Master/Slave

Active current sharing allows up to six identical units to be connected in an autoparallel configuration for six times the output power.

In Advanced Parallel Master/Slave Mode, total current is programmed and reported by the Master, up to six supplies act as one.

### Series operation

Up to two units may be connected in series to increase the output voltage or to provide bipolar output.

## Remote Programming via USB, RS-232 & RS-485 Interface

Standard Serial Interface allows chain control of up to 31 power supplies on the same bus with built-in RS-232 & RS-485 Interface.

## Z<sup>+</sup> Interface Options

### Programming options Factory installed

#### Isolated Analog Programming

- Four channels to Program and Monitor Voltage and Current.
- Isolation allows operation with floating references in harsh electrical environments.
- Choose between programming with Voltage or Current.
- Connection via removable terminal block: Phoenix MC1,5/8-ST-3.81.
- Voltage Programming, user-selectable 0 – 5 V or 0 – 10 V signal.
  - Power supply Voltage and Current Programming Accuracy  $\pm 1\%$
  - Power supply Voltage and Current Monitoring Accuracy  $\pm 1.5\%$
- Current Programming with 4 – 20 mA signal.
  - Power supply Voltage and Current Programming Accuracy  $\pm 1\%$
  - Power supply Voltage and Current Monitoring Accuracy  $\pm 1.5\%$

**P/N: IS510**

**P/N: IS420**

#### Digital Programming via IEEE Interface

- IEEE 488.2 SCPI compliant
- Program Voltage
- Program Current
- Measure Voltage
- Measure Current
- Over Voltage setting and shutdown
- Current Fold-back shutdown
- Error and Status Messages
- Multi-Drop
  - Allows IEEE Master to control up to 31 slaves over RS-485 daisy-chain
  - Only the Master needs be equipped with IEEE Interface

**P/N: IEEE**

## LAN Interface Compliant to Class C

P/N: LAN

- Meets all **LXI-C** Requirements
- Compatible with most standard Networks
- VISA & SCPI Compatible
- TCP / UDP Socket Programming
- Address Viewable on Front Panel
- Fixed and Dynamic Addressing
- LAN Fault Indicators
- Auto-detects LAN Cross-over Cable
- Fast Startup

Allows LAN/IEEE Master to control up to 31 slaves over RS-485 daisy-chain

Only the Master needs be equipped with LAN/IEEE Interface supplies act as one.

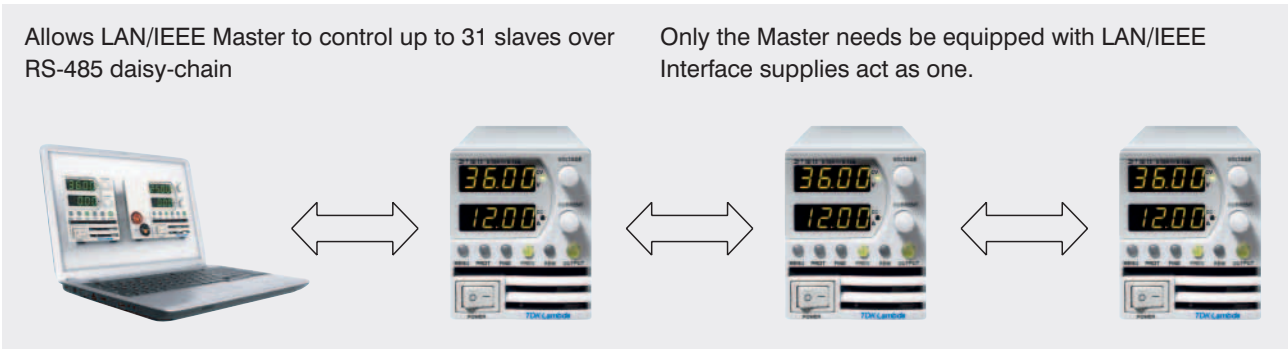

Multi-drop

## Z+ Options 200/400/600/800 W Models



### Front Panel Output Jacks

Up to 60V Output module

P/N: Z\_ \_ - \_ \_ - L

Up to 25A Output current via front panel jacks

### Z+ Assemblies

Dual Output Housing (for 105 mm)

200 W / 400 W / 600 W / 800 W

Triple Output Housing (for 70 mm)

200 W / 400 W / 600 W / 800 W

P/N: Z-NL200

(same p/n for both Dual & Triple Output Housing)



## 19" Rack Mounted to 4.8 kW

P/N: Z-NL100





Six units (70 mm) can be assembled into 19-Inch rack/2U high  
 Four units (105 mm) can be assembled into 19-Inch rack/2U high  
 to meet your configuration requirements.

In cases where the entire rack is not occupied with power units,  
 P/N: Z-BP for 70 mm, P/N: Z-WBP for 05mm blank panels can be  
 installed.

Module Type	200 W	400 W	600 W	800 W
0~10 V	20 A	40 A	60 A	75 A
0~20 V	10 A	20 A	30 A	40 A
0~36 V	6 A	12 A	18 A	24 A
0~60 V	3.5 A	7 A	10 A	14 A
0~100 V	2 A	4 A	6 A	8 A
19" rack width	1/6 width	1/6 width	1/6 width	1/6 width
19" rack width	1/4 width	1/4 width	1/4 width	1/4 width

## Z+ Accessories

### AC Cords sets

Region	Europe	United Kingdom	Middle East	North America
Output Power AC Cords	850 W 10 A/250 V AC L=2 m	850 W 10A/250 V AC L=2m	850 W 10 A/250 V AC L=2 m	850 W 13 A/125 V AC L=2 m
Wall Plug Power Supply Connector	INT'L 7/III IEC320-C15	BS1363 IEC320-C15	SI-32 IEC320-C15	NEMA 5-15P IEC320-C15
				
Part Number	P/N: Z/E	P/N: Z-GB	P/N: Z/I	P/N: Z/U

### Communication Cable

RS-232/RS-485 Cable is used to connect the power supply to the PC Controller

Mode	RS-485	RS-232
PC Connector Communication Cable Power Supply Connector	DB-9F Shield Ground L=2 m EIA/TIA-568A (RJ-45)	DB-9F Shield Ground L=2 m EIA/TIA-568A (RJ-45)
Part Number	Z/485-9	Z/232-9

### Serial link cable (included with power supplies)

Daisy-chain up to 31 Z+ Series power supplies.

Mode	Power Supply Connector	Communication Cable	P/N
RS-485	EIA/TIA-568A (RJ-45)	Shield Ground L=50 cm	Z/RJ45



The Genesys™ family of programmable power supplies sets a new standard for flexible, reliable, AC/DC power systems in OEM, Industrial and Laboratory applications. Genesys™ constant voltage/constant current programmable power supplies are available in versions from 750 W to 15 kW. Units can be run in master/slave parallel to facilitate higher powered systems. Comprehensive analogue and digital control features come as standard along with free downloadable software and drivers from our website. Genesys™ has many additional options

available such as LAN *LXI* and GPIB interfaces, power sink and special “fast speed” models optimized for laser diodes and automotive test programmes. Applications cover many industries including ATE test and component burn-in systems, semiconductor and flat panel display manufacturing processes, water purification, ship-borne ROV power, MRI electroplating, particle accelerators and renewable energy system inverter testing.

## Features

- High Power Density
  - 750/1500/2400 W in 1 U
  - 750 W in 1/2 19" 1 U
  - 3.3/5 kW in 2 U
  - 10/15 kW in 3 U
- Wide Range of popular worldwide AC inputs
  - 1-phase wide range (85–265 V AC)
  - 1-phase (230 V AC)
  - 3-phase (208 V AC, 400 V AC, 480 V AC) model dependent
- Active/passive Power Factor Correction (Single-Phase & Three-Phase AC Input)
- Output Voltage up to 600 V, Current up to 1000 A
- Built-in RS-232/RS-485 Interface Standard
- Global Commands for Serial RS-232/RS-485 Interface
- Auto-Re-Start/Safe-Start: user-selectable
- Last-Setting Memory; Front panel lockout
- High Resolution 16 bit ADCs & DACs
- Low Ripple & Noise
- Front Panel Lock selectable from Front Panel or Software
- Reliable Encoders for Voltage and Current Adjustment
- Constant Voltage/Constant Current auto-crossover
- Parallel Operation with Active Current Sharing; up to four identical units
- Advanced Parallel Master/Slave
  - Total Current is programmed and measured via the master
- **NEW** Integrated Power Sink Option for 1 U 750 W and 1500 W models (up to 60 V)
- Independent Remote ON/OFF and Remote Enable/Disable
- External Analog Programming and Monitoring (user-selectable 0–5 V & 0–10 V)
- Programmable fold-back delay for current limit
- Auxiliary output 5 V/0.2 A isolated, 15 V/0.2 A non isolated (GEN 2.4 kW only)
- Reliable Modular and SMT Design
- 19" Rack Mount capability for ATE and OEM applications
- Optional Interfaces
  - Isolated Analog Programming and Monitoring Interface (0–5 V/0–10 V & 4–20 mA)
  - IEEE 488.2 SCPI (GPIB) Multi-Drop
  - LXI** compliant LAN interface
- LabView™ Genesys™ Control (Runtime Modul) and Drivers
- Five Years Warranty

Worldwide Safety Agency Approvals; CE Mark for LVD and EMC Regulation



## Applications

**Genesys™** power supplies have been designed to meet the demands of a wide variety of applications. System Designers will appreciate new, standard, remote programming features such as Global commands. Also, new high-speed status monitoring is available for the RS-485 bus.

**Test Systems** using the IEEE-488 bus may achieve significant cost savings by incorporating the Optional IEEE Multi-Drop Interface for a Master and up to 30 RS-485 Multi-Drop Slaves.

**Higher power systems** can be configured with up to four Genesys™ units. Each Genesys™ unit can be stacked

zero space between them (zero stack). Between the modules there is no additional space required.

**Flexible configuration** is provided by the complete Genesys™ family: 1 U 750 W Half-Rack, 1 U 750 – 2400 W, 2 U 3.3/5 kW, 3 U 10/15 kW Full-Rack. All are identical in Front Panel, Rear Panel Analog, and all Digital Interface Commands.

**OEM Designers** have a wide variety of Inputs and Outputs from which to select depending on application and location.

# Genesys™ GENH 750 W in 1 U 1/2 19" rack

Model	Output Voltage [V DC]	Output Current [A]	Output Power [W]
GENH6-100	0~6	0~100	600
GENH8-90	0~8	0~90	720
GENH12.5-60	0~12.5	0~60	750
GENH20-38	0~20	0~38	760
GENH30-25	0~30	0~25	750
GENH40-19	0~40	0~19	760
GENH60-12.5	0~60	0~12.5	750
GENH80-9.5	0~80	0~9.5	760
GENH100-7.5	0~100	0~7.5	750
GENH150-5	0~150	0~5	750
GENH300-2.5	0~300	0~2.5	750
GENH600-1.3	0~600	0~1.3	780

## How to order

### Power Supply Identification / GENH 750 W 1U

GEN H	600	-	1.3	-		-	E
Series name	Output voltage (0~600 V)		Output current (0~1.3 A)		Option: IEEE IS510 IS420 LAN		AC Cable E. Europe GB. UK J. Japan I. Middle East U. USA O. unterminated BLANK: None

### Factory Option GENH 750 W

Factory Option	P/N:
RS-232/RS-485 Interface Built-in Standard	-
IEEE 488.2 (GPIB) Interface	IEEE
Voltage Programming Isolated Analog Interface	IS510
Current Programming Isolated Analog Interface	IS420
LAN Interface (Complies with <b>LXI</b> class C)	LAN

## Front panel description GENH 750 W in 1U 1/2 19" rack



- ① ON/OFF Switch
- ② Air Intake allows zero stacking for maximum system flexibility and power density.
- ③ Reliable encoder controls Output Voltage and sets Address, OVP, UVL Limits.
- ④ Volt Display shows Output Voltage and directly displays OVP, UVL and Address settings.
- ⑤ Reliable encoder controls Output Current, sets Baud rate and Advanced Parallel Mode.
- ⑥ Current Display shows Output Current and displays Baud rate. Displays total current in Parallel Master/Slave Mode.
- ⑦ Function/Status LEDs:
  - Alarm                      ● Fine Control            ● Preview Settings
  - Fold-back Mode       ● Remote Mode       ● Output On
- ⑧ Push-buttons allow flexible user configuration:
  - Coarse and Fine adjustment of Output Voltage/Current and Advanced Parallel Master/Slave Mode.
  - Preview settings and set Voltage/Current with Output OFF, Front Panel Lock.
  - Parallel Master/Slave
  - Set OVP and UVL Limits
  - Set Current Fold-back
  - Local/Remote Mode and select Address and Baud rate.
  - Output ON/OFF and Auto-Re-Start/Safe-Start Mode.

## Rear panel description GENH 750 W in 1U 1/2 19" rack

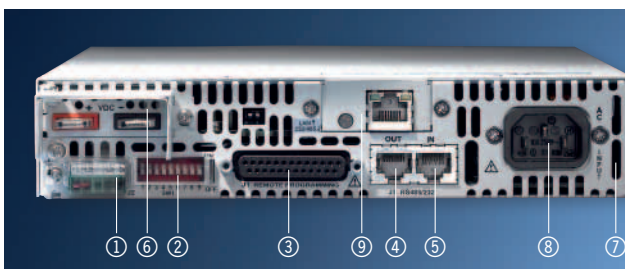

- ① Remote/Local Output Voltage Sense Connections.
- ② DIP Switches select 0–5 V or 0–10 V Programming and other functions.
- ③ DB25 (Female) connector allows (Non-isolated) Analog Program and Monitor and other functions.
- ④ RS-485 OUT to other Genesys™ Power Supplies.
- ⑤ RS-232/RS-485 IN Remote Serial Programming.
- ⑥ Output Connections:
  - 750 W (shown) units: Rugged busbars up to 60 V Output. Wire clamp terminal for output 80 to 600 V models.
- ⑦ Exit air assures reliable operation when zero stacked.
- ⑧ Input:
  - IEC 320 connector for 750 W models (85 – 265 V AC)
- ⑨ Optional Interface Position for IEEE 488.2 SCPI or Isolated Analog Interface or LAN interface (shown).

# Genesys™ GEN 750/1500 W in 1U 19" rack

Model	Output Voltage [V DC]	Output Current [A]	Output Power [W]
GEN6-100 GEN6-200	0~6	0~100 0~200	600 1200
GEN8-90 GEN8-180	0~8	0~90 0~180	720 1440
GEN12.5-60 GEN12.5-120	0~12.5	0~60 0~120	750 1500
GEN20-38 GEN20-76	0~20	0~38 0~76	760 1520
GEN30-25 GEN30-50	0~30	0~25 0~50	750 1500
GEN40-19 GEN40-38	0~40	0~19 0~38	760 1520
GEN50-30	0~50	0~30	1500
GEN60-12.5 GEN60-25	0~60	0~12.5 0~25	750 1500
GEN80-9.5 GEN80-19	0~80	0~9.5 0~19	760 1520
GEN100-7.5 GEN100-15	0~100	0~7.5 0~15	750 1500
GEN150-5 GEN150-10	0~150	0~5 0~10	750 1500
GEN300-2.5 GEN300-5	0~300	0~2.5 0~5	750 1500
GEN600-1.3 GEN600-2.6	0~600	0~1.3 0~2.6	780 1560

## How to order

### Power Supply Identification GEN 750/1500 W 1U

GEN	600	-	2.6	-		-	
Series name	Output voltage (0~600 V)		Output current (0~2.6 A)		Option: IEEE IS510 IS420 LAN		AC Cable (750 W only) E. Europe GB. UK J. Japan I. Middle East U. USA 0. unterminated BLANK: None

### Factory Option GEN 750/1500 W

Factory Option	P/N:
RS-232/RS-485 Interface Built-in Standard	-
IEEE 488.2 (GPIB) Interface	IEEE
Voltage Programming Isolated Analog Interface	IS510
Current Programming Isolated Analog Interface	IS420
LAN Interface (Complies with <b>LXI</b> class C)	LAN

## Front panel description GEN 750/1500 W in 1U 19" rack

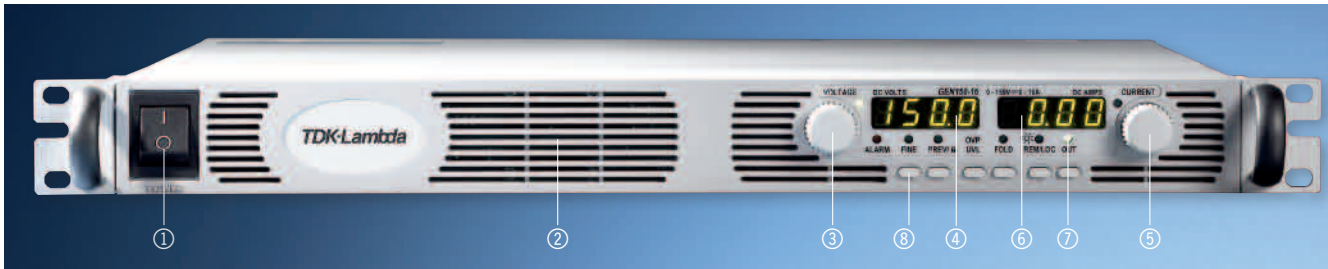

- ① ON/OFF Switch
- ② Air Intake allows zero stacking for maximum system flexibility and power density.
- ③ Reliable encoder controls Output Voltage and sets Address, OVP, UVL Limits.
- ④ Volt Display shows Output Voltage and directly displays OVP, UVL and Address settings.
- ⑤ Reliable encoder controls Output Current, sets Baud rate and Advanced Parallel Mode.
- ⑥ Current Display shows Output Current and displays Baud rate. Displays total current in Parallel Master/Slave Mode.
- ⑦ Function/Status LEDs:
  - Alarm
  - Fine Control
  - Preview Settings
  - Fold-back Mode
  - Remote Mode
  - Output On
- ⑧ Push-buttons allow flexible user configuration:
  - Coarse and Fine adjustment of Output Voltage/Current and Advanced Parallel Master or Slave Mode.
  - Preview settings and set Voltage/Current with Output OFF, Front Panel Lock.
  - Parallel Master/Slave
  - Set OVP and UVL Limits
  - Set Current Fold-back Protection
  - Local/Remote Mode and select Address and Baud rate.
  - Output ON/OFF and Auto-Re-Start/Safe-Start Mode.

## Rear panel description GEN 750/1500 W in 1U 19" rack

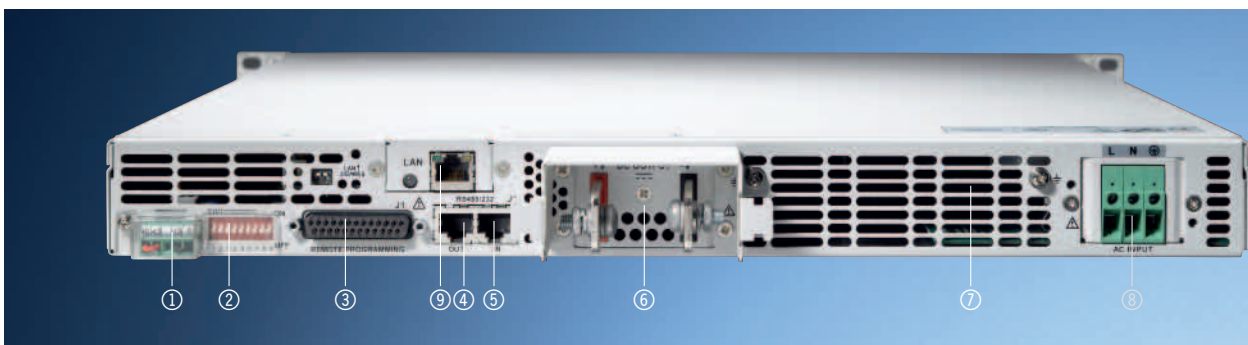

- ① Remote/Local Output Voltage Sense Connections.
- ② DIP Switches select 0–5 V or 0–10 V Programming and other functions.
- ③ DB25 (Female) connector allows (Non-isolated) Analog Program and Monitor and other functions.
- ④ RS-485 OUT to other Genesys™ Power Supplies.
- ⑤ RS-232/RS-485 IN Remote Serial Programming.
- ⑥ Output Connections:  
Rugged busbars up to 60 V Output; Wire clamp connector for output > 60 V models.
- ⑦ Exit air assures reliable operation when zero stacked.
- ⑧ Wide-Range Input 85 – 265 V AC continuous, 47/63 Hz with Active Power Factor Correction (0.99 typical).  
AC Input Connector: 750 W (IEC320), 1500 W (screw terminal-shown).
- ⑨ Optional Interface Position for IEEE 488.2 SCPI or Isolated Analog Interface or LAN interface (shown).

# Specifications Genesys™ GEN/GENH 750/1500 W

Model (750 W)	GEN	6-100	8-90	12.5-60	20-38
Rated output voltage (*1)	[V]	6	8	12.5	20
Rated output current (*2)	[A]	100	90	60	38
Rated output power	[W]	600	720	750	760
Efficiency at 100/200 V AC (*3)	[%]	76/78	77/80	81/84	82/85
Model (750 W)	GENH	6-100	8-90	12.5-60	20-38
Rated output voltage (*1)	[V]	6	8	12.5	20
Rated output current (*2)	[A]	100	90	60	38
Rated output power	[W]	600	720	750	760
Efficiency at 100/200 V AC (*3)	[%]	76/78	77/80	81/84	82/85
Constant Current Mode (750 W)	GEN/GENH				
Max. line regulation (0.01 % of Io + 2 mV) (*4)	[mA]	12	11	8.0	5.8
Max. load regulation (0.02 % of Io + 5 mV) (*6)	[mA]	25	23	17	12.6
Ripple RMS 5 Hz~1 MHz (*7)	[mA]	200	180	120	76
Temperature coefficient	[ppm/°C]	100 ppm/°C from rated output voltage, following 30 minutes			
Model (1500 W)	GEN	6-200	8-180	12.5-120	20-76
Rated output voltage (*1)	[V]	6	8	12.5	20
Rated output current (*2)	[A]	200	180	120	76
Rated output power	[W]	1200	1440	1500	1520
Efficiency at 100/200 V AC (*3)	[%]	77/79	78/81	82/85	83/86
Constant Current Mode (1500 W)					
Max. line regulation (0.01 % of Io + 2 mV) (*4)	[mA]	22	20	14	9.6
Max. load regulation (0.02 % of Io + 5 mV) (*6)	[mA]	45	41	29	20.2
Ripple RMS 5 Hz~1 MHz (*7)	[mA]	400	360	240	152
Temperature coefficient	[ppm/°C]	100 ppm/°C from rated output voltage, following 30 minutes			
Constant Voltage Mode (750/1500 W)					
Max. line regulation (0.01 % of Vo + 2 mV) (*4)	[mV]	2.6	2.8	3.3	4
Max. load regulation (0.01 % of Vo + 2 mV) (*5)	[mV]	2.6	2.8	3.3	4
Ripple and noise p-p 20 MHz (*9)	[mV]	60	60	60	60
Ripple RMS 5 Hz~1 MHz (*9)	[mV]	8	8	8	8
Remote sense compensation/line	[V]	1	1	1	1
Temperature coefficient	[ppm/°C]	100 ppm/°C from rated output voltage, following 30 minutes warm			
Up-prog. response time, 0~Vo Rated	[ms]	80 ms, N.L / F.L, resistive load			
Down-prog. response time full-load	[ms]	10	50	50	50
Down-prog. response time no-load	[ms]	500	600	700	800
Transient response time (*8)		Less than 1 ms for models up to and including 100 V, 2 ms for			
Protective Functions (750/1500 W)					
OVP trip point	[V]	0.5~7.5	0.5~10	1~15	1~24
Over Temperature Protection		User-selectable, latched or non-latched			
OCP		0~105 % Constant Current			
OCP Fold-back		Output shut-down when power supply change from CV to CC. User-selectable.			
OVP type		Inverter shut-down, manual reset by AC input recycle or by OUT button or by communication port.			

\*1: Minimum voltage is guaranteed to maximum 0.2 % of Vo Rated.

\*2: Minimum current is guaranteed to maximum 0.4 % of Io Rated.

\*3: At maximum output power.

\*4: 85~132 V AC or 170~265 V AC, constant load.

\*5: From No-load to Full-load, constant input voltage.

\*6: For load voltage change, equal to the unit voltage rating, constant input voltage.

30-25	40-19		60-12.5	80-9.5	100-7.5	150-5	300-2.5	600-1.3
30	40		60	80	100	150	300	600
25	19		12.5	9.5	7.5	5	2.5	1.3
750	760		750	760	750	750	750	780
82/85			83/87					
30-25	40-19		60-12.5	80-9.5	100-7.5	150-5	300-2.5	600-1.3
30	40		60	80	100	150	300	600
25	19		12.5	9.5	7.5	5	2.5	1.3
750	760		750	760	750	750	750	780
83/87								
4.5	3.9		3.25	2.95	2.75	2.5	2.25	2.13
10	8.8		7.5	6.9	6.5	6.0	5.5	5.26
63	48		38	29	23	18	13	8
warm up								
30-50	40-38	50-30	60-25	80-19	100-15	150-10	300-5	600-2.6
30	40	50	60	80	100	150	300	600
50	38	30	25	19	15	10	5	2.6
1500	1520	1500	1500	1520	1500	1500	1500	1560
83/86	84/88							
7.0	5.8	5	4.5	3.9	3.5	3.0	2.5	2.26
15	12.6	11	10	8.8	8.0	7.0	6.0	5.52
125	95	85	75	57	45	35	25	12
warm up								
5	6	7	8	10	12	17	32	62
5	6	7	8	10	12	17	32	62
60	60	60	60	80	80	100	150	300
8	8	8	8	8	8	10	25	60
1.5	2	2	3	4	5	5	5	5
up								
				150 ms, N.L./F.L, resistive load				250
80	80	80	80	150	150	150	150	250
900	1000	1100	1100	1200	1500	2000	2500	4000
models above 100 V								
2~36	2~44	5~57	5~66	5~88	5~110	5~165	5~330	5~660

\*7: For 6 V models the ripple is measured at 2~6 V output voltage and full output current. For other models, the ripple is measured at 10~100 % output voltage and full output current.

\*8: Time for the output voltage to recover within 0.5 % of its rated for a load change 10~90 % of rated output, Output set-point: 10~100 %.

\*9: For 6 V~300 V models: measured with JEITA RC-9131 1:1 probe. For 600 V model: measured with 10:1 probe. Accuracy: Values have been calculated at Vo Rated & Io Rated.

# Specifications Genesys™ GEN/GENH 750/1500 W

Interface RS-232 & RS-485 or Optional GPIB / LAN Interface					
Model		6	8	12.5	20
<b>Remote Current Programming (16 bit) (750 W)</b>					
Resolution (0.012 % of Io Rated)	[mA]	12	10.8	7.2	4.56
Accuracy (0.1 % Io Rated + 0.1 % of Io Actual Output)	[mA]	200	180	120	76
<b>Readback Current (750 W)</b>					
Resolution (0.012 % of Io Rated)	[mA]	12	10.8	7.2	4.56
Accuracy (0.3 % Io Rated + 0.1 % of Io Actual Output)	[mA]	400	360	240	152
<b>Remote Current Programming (16 bit) (1500 W)</b>					
Resolution (0.012 % of Io Rated)	[mA]	24	21.6	14.4	9.12
Accuracy (0.1 % Io Rated + 0.1 % of Io Actual Output)	[mA]	400	360	240	152
<b>Readback Current (1500 W)</b>					
Resolution (0.012 % of Io Rated)	[mA]	24	21.6	14.4	9.12
Accuracy (0.3 % Io Rated + 0.1 % of Io Actual Output)	[mA]	800	720	480	304
<b>Remote Voltage Programming (16 bit) (750/1500 W)</b>					
Resolution (0.012 % of Vo Rated)	[mV]	0.72	0.96	1.50	2.40
Accuracy (0.05 % Vo Rated + 0.05 % of Vo Actual Output)	[mV]	6.0	8.0	12.5	20
<b>Readback Voltage (750/1500 W)</b>					
Resolution (0.012 % of Vo Rated)	[mV]	0.72	0.96	1.50	2.40
Accuracy (0.1 % Vo Rated + 0.1 % of Vo Actual Output)	[mV]	12	16	25	40
<b>OVP/UVL Programming (750 W/1500 W)</b>					
Resolution (0.1 % of Vo Rated)	[mV]	6	8	12	20
Accuracy (1 % of Vo Rated)	[mV]	60	80	125	200

Analog Programming and Monitoring (750 W/1500 W)	
Vout Voltage Programming	0~100 %, 0~5 V or 0~10 V, user-selectable. Accuracy and linearity: ± 0.5 % of rated Vout.
Iout Voltage Programming	0~100 %, 0~5 V or 0~10 V, user-selectable. Accuracy and linearity: ± 1 % of rated Iout.
Vout Resistor Programming	0~100 %, 0~5/10 kΩ full scale, user-selectable. Accuracy and linearity: ± 1 % of rated Vout.
Iout Resistor Programming	0~100 %, 0~5/10 kΩ full scale, user-selectable. Accuracy and linearity: ± 1.5 % of rated Iout.
On/Off control (rear panel)	By electrical. Voltage: 0~0.6 V/2~15 V, or dry contact, user-selectable logic
Output current monitor	0~5 V or 0~10 V, accuracy: 1 %, user-selectable
Output voltage monitor	0~5 V or 0~10 V, accuracy: 1 %, user-selectable
Power supply OK signal	TTL high (4~5 V) -OK, 0 V-Fail 500 series resistance
CV/CC indicator	CV: TTL high (4~5 V), CC: TTL low (0~0.6 V), maximum Voltage: 30 V, sink current: 10 mA
Enable/Disable	Dry contact. Open: off, Short: on. Max. voltage at Enable/Disable in: 6 V
Local/Remote analog control	By electrical signal (TTL) or Open/Short: 0~0.6 V or short: Remote, 4~5 V or open: Local
Local/Remote analog control indicator	Open collector, Local: Open, Remote: On. Maximum voltage: 30 V, maximum sink current: 5 mA

30	40	50	60	80	100	150	300	600
3.0	2.28		1.50	1.14	0.90	0.60	0.30	0.16
50	38		25	19	15	10	5.0	2.6
3.0	2.28		1.50	1.14	0.90	0.60	0.30	0.16
100	76		50	38	30	20	10	5.2
6.0	4.56	3.60	3.0	2.28	1.80	1.20	0.60	0.32
100	76	60	50	38	30	20	10	5.2
6	4.56	3.60	3.0	2.28	1.80	1.20	0.60	0.32
200	152	120	100	76	60	40	20	10.4
3.60	4.80	6	7.2	9.6	12	18	36	72
30	40	50	60	80	100	150	300	600
3.60	4.80	6.0	7.2	9.6	12	18	36	72
60	80	100	120	160	200	300	600	1200
30	40	50	60	80	100	150	300	600
300	400	500	600	800	1000	1500	3000	6000

Front Panel (750 W/1500 W)	
Control functions	Vout/lout manual adjust by separate encoders (coarse and fine adjustment selectable)
	OVP/UVL manual adjust by Volt. Adjust encoder
	AC on/off, Output on/off, Re-start modes (auto, safe), Fold-back control (CV to CC), Go to local control
	Address selection by Voltage (or current) adjust encoder. Number of addresses: 31
	RS232/485 and IEEE488.2 selection by IEEE enable switch and DIP switch
	Baud rate selection: 1200, 2400, 4800, 9600 and 19200
Display	Voltage 4 digits, accuracy: 0.5 % ±1 count
	Current 4 digits, accuracy: 0.5 % ±1 count
Indications	Voltage, Current, Alarm, Fine, Preview, Fold-back, Local, Output On, Front Panel Lock
Input Characteristics	
Input voltage/freq. (*1)	85~265 V AC continuous, 47~63 Hz, Single-Phase
Power Factor	0.99 @100/200 V AC, rated output power
EN61000-3-2,3 compliance	Complies with EN61000-3-2 class A and EN61000-3-3 at 20~100 % output power
Input current 100/200 V AC	10.5 A / 5 A (750 W), 21 A / 11 A (1500 W)
Inrush current 100/200 V AC	Less than 25 A (750 W), Less than 50 A (1500 W)
Hold-up time	More than 20 ms, 100 V AC, at 100 % load

\*1: For cases where conformance to various safety standards (UL, IEC etc.) is required, to be described as 100-240 V AC (50/60 Hz).

Sequel ▶





# Specifications Genesys™ GEN/GENH 750/1500 W

Power Supply Configuration	
Parallel operation	Up to 4 units in master/slave mode with single wire current balance connection
Series operation	Up to 2 units with external diodes. 600 V max. to chassis ground
Environmental Conditions	
Operating temperature	0~50 °C, 100 % load
Storage temperature	-20~70 °C
Operating humidity	30~90 % RH (non-condensing)
Storage humidity	10~95 % RH (non-condensing)
Vibration	MIL-810E, method 514.4, test cond. I-3.3.1 The EUT is fixed to the vibrating surface
Shock	Less than 20 g, half sine, 11 ms unit is unpacked
Altitude	Operating: 10,000 ft (3,000 m), Derate output current by 2 %/100 m above 2,000 m, Non-operating: 40,000 ft (12,000 m)
EMC	
Applicable Standards:	
ESD	IEC1000-4-2. Air-disch. -8 kV, contact disch. -4 kV
Fast transients	IEC1000-4-4. 2 kV
Surge immunity	IEC1000-4-5. 1 kV line to line, 2 kV line to ground
Conducted immunity	IEC1000-4-6, 3 V
Radiated immunity	IEC1000-4-3, 3 V/m
Conducted emission	EN55022B, FCC part 15J-B, VCCI-B
Radiated emission	EN55022A, FCC part 15-A, VCCI-A
Voltage dips	EN61000-4-11
Conducted emission	EN55022B, FCC part 15-B, VCCI-B
Radiated emission	EN55022A, FCC part 15-A, VCCI-A
Safety	
Applicable standards:	CE Mark, UL60950-1, EN60950-1: 2006 (Edition 2) Vout ≤40 V: Output is SELV, IEEE/Isolated analog are SELV 40 <Vout <400 V: Output is hazardous, IEEE/Isolated analog are SELV 400 <Vout <600 V: Output is hazardous, IEEE/Isolated analog are not SELV
Withstand voltage	Vout ≤40 V models: Input-Outputs (SELV): 3.0 kV RMS 1 min, Input-Ground: 2.0 kV RMS 1 min 40 <Vout ≤600 V models: Input-Haz. Output: 2.5 kV RMS 1 min, Input-SELV: 3 kV RMS 1 min Hazardous Output-SELV: 1.9 kV RMS 1 min, Hazardous Output-Ground: 1.9 kV RMS 1 min Input-Ground: 2 kV RMS 1 min
Insulation resistance	More than 100 MΩ at 25 °C, 70 % RH, 500 V DC
Mechanical Construction GENH 750 W	
Cooling	Forced air flow: from front to rear. No ventilation holes at the top or bottom of the chassis; Variable fan speed.
Dimensions (WxHxD)	W: 214.0 mm, H: 43.6 mm, (57.0 mm Benchtop version), D: 437.5 mm (excluding connectors, encoders, handles, etc.)
Weight	4.5 kg (9.9 lbs)
AC Input connector	IEC320 AC Inlet
Output connectors	6 V to 60 V models: Bus-bars (hole Ø 6.5 mm). 80 V to 600 V models: Mating plug, Phoenix P/N: GIC 2.54/4-ST-7.62

Mechanical Construction GEN 750 W/1500 W	
Cooling	Forced air flow: from front to rear. No ventilation holes at the top or bottom of the chassis; Variable fan speed.
Dimensions (WxHxD)	W: 442.8 mm, H: 43.6 mm, D: 432.8 mm (excluding connectors, encoders, handles, etc.)
Weight	750 W: 7 kg (15 lbs), 1500 W: 8.5 kg (18 lbs)
AC Input connector	750 W: IEC320 AC Inlet 1500 W: Screw terminal block, Phoenix P/N: FRONT-4-H-7.62, with strain relief
Output connectors	6 V to 60 V models: Bus-bars (hole Ø 8.5 mm). 80 V to 600 V models: wire clamp connector, Phoenix P/N: FRONT-4-H-7.62
Reliability specs	
Warranty	5 years

## Accessories Genesys™ GEN/GENH 750 W

### AC Cords sets

Region	Europe	United Kingdom	Japan	Middle East	North America
Output Power AC Cords	750 W 10 A/250 V AC L=2 m	750 W 10 A/250 V AC L=2 m	750 W 13 A/125 V AC L=2 m	750 W 10 A/250 V AC L=2 m	750 W 13 A/125 V AC L=2 m
Wall Plug Power Supply Connector	INT'L 7/VII IEC320-C13	BS1363 IEC320-C13	IEC320-C13	SI-32 IEC320-C13	NEMA 5-15P IEC320-C13
					
Part Number	P/N: GEN/E	P/N: GEN/GB	P/N: GEN/J	P/N: GEN/I	P/N: GEN/U

### Rack mounting applications

The Rack Mounted kit allows the units to be zero stacking for maximum system flexibility and power density without increasing the 1 U height of the units. To install one GENH 750 W one unit or two units side-by-side in a standard 19" rack in 1 U (1.75") height, use option kit.

P/N:GENH/RM



### Single unit installation

Single GENH 750 W power supply in a standard 19" rack in 1 U (1.75") height.

### Dual unit installation

Two GENH 750 W power supplies side-by-side in a standard 19" rack in 1 U (1.75") height.



### Benchtop applications

The benchtop mounted kit allows the units to be zero stacking for maximum system flexibility and power density without increasing the 1 U height of the units. To install a GENH 750 W two units or three units one on top of the other use option kit.

P/N:GENH/MO



NEW

# Genesys™ GEN 750/1500 W with Power Sink (Option)

The market leading Genesys™ Programmable Power Supplies offer a wide variety of useful integrated functions and features, making them into an extremely effective and easy to use tool for many applications. Now Genesys™ 1 U 750 W and 1500 W models are available with a Power Sink Option (PSINK) that can absorb energy from the load.

## Features

- Maintains output voltage setting regardless of whether output power is positive or negative (source and sink)
- Can absorb 200 W peak power

## Applications

- Ideal solution for testing electric motors with PWM-speed control. These systems often return power to the power supply during braking conditions.
- ATE systems requiring fast down programming at no load conditions.
- Testing capacitors and batteries.
- Automotive Motor Test eg. power window drives, mirror and seat adjustment.

Model	Output Voltage [V DC]	Output Current [A]	Output Power [W]	Option PSINK
GEN12.5-60 GEN12.5-120	0~12.5	0~60 0~120	750 1500	• • <b>NEW</b>
GEN20-38 GEN20-76	0~20	0~38 0~76	760 1520	• •
GEN30-25 GEN30-50	0~30	0~25 0~50	750 1500	• •
GEN40-19 GEN40-38	0~40	0~19 0~38	760 1520	• •
GEN60-12.5 GEN60-25	0~60	0~12.5 0~25	750 1500	• •

## How to order

### Power Supply Identification with Power Sink

GEN	60	-	25	-		-	PSINK	-	LN
Series name	Output voltage		Output current		Option: IEEE IS510 IS420 LAN				(Low Noise) Up to 60 V only

### Factory Option GEN 750/1500 W

Factory Option	P/N:
RS-232/RS-485 Interface Built-in Standard	-
IEEE 488.2 (GPIB) Interface	IEEE
Voltage Programming Isolated Analog Interface	IS510
Current Programming Isolated Analog Interface	IS420
LAN Interface (Complies with <b>LXI</b> class C)	LAN
Power Sink	PSINK

## Source and Sink

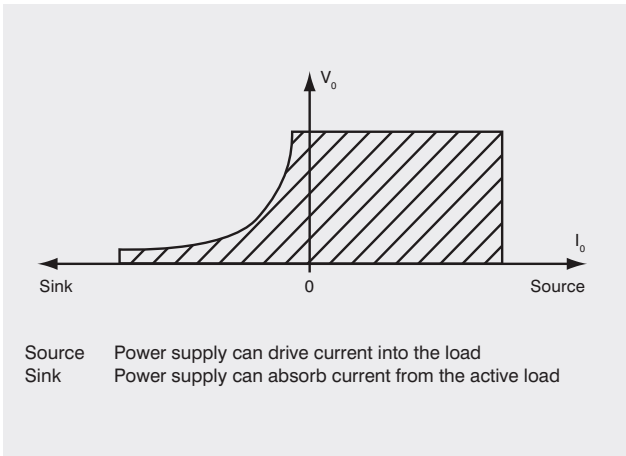

## Typical load current PWM – controlled DC motor

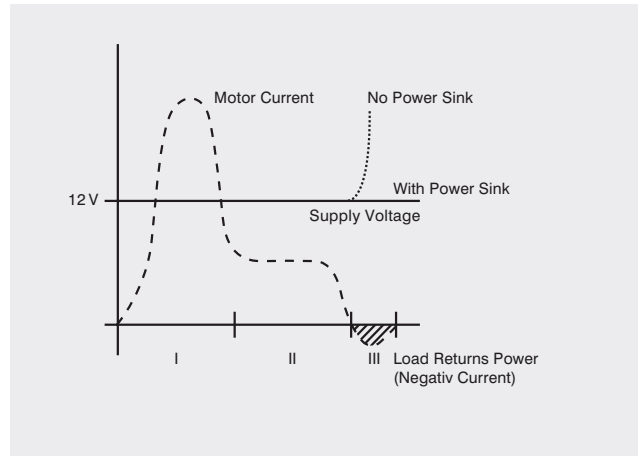

## Model GEN 60-25 no Power Sink

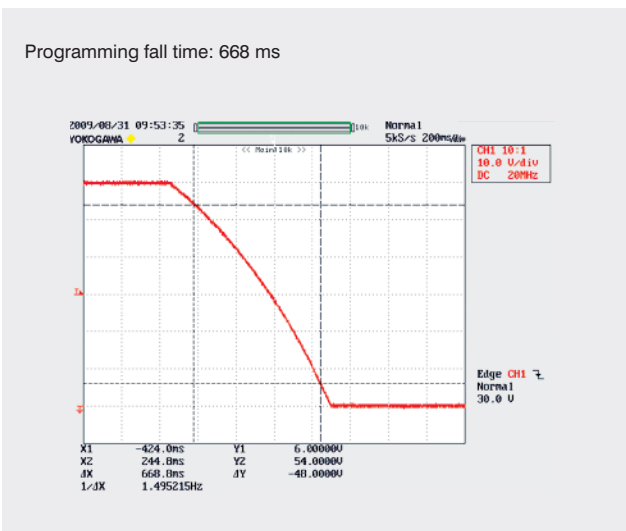

## Model GEN 60-25 with Power Sink

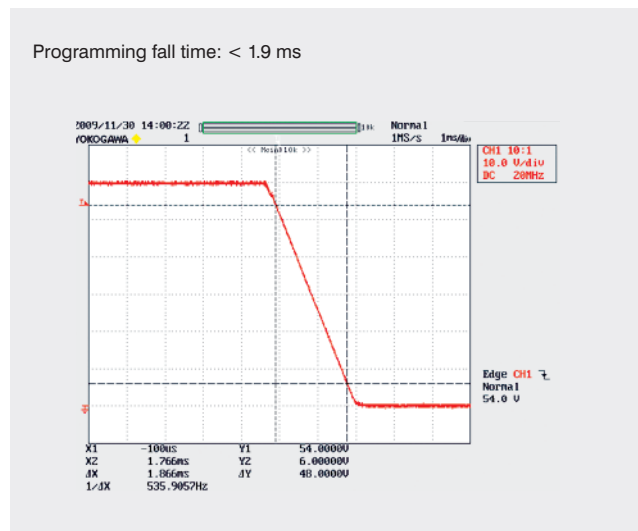

**NEW** Specifications Genesys™ GEN 750 W Power Sink (Option)

Specifications Power Sink (750 W)		GEN12.5-60 PSINK
<b>Sink power rating</b>		
Max. peak power (thermal limited) Tamb = 25 °C	[W]	200
Max. peak power (thermal limited) Tamb = 50 °C	[W]	100
Max. sink peak power duration	[s]	30
Recovery time for max. peak power	[s]	1200
Max. continues power, Tamb = 25 °C	[W]	45
Max. continues power, Tamb = 50 °C	[W]	30
Power derate above 25 °C	[%/°C]	1.33
<b>Duty cycle for use at peak power</b>		
PSINK = 70 W, Tamb = 25 °C	[s]	ton ≤ 10 s, toff ≥ 10 s
PSINK = 70 W, Tamb = 25 °C	[s]	ton ≤ 20 s, toff ≥ 21 s
PSINK = 70 W, Tamb = 25 °C	[s]	ton ≤ 30 s, toff ≥ 36 s
PSINK = 105 W, Tamb = 25 °C	[s]	ton ≤ 10 s, toff ≥ 22 s
PSINK = 105 W, Tamb = 25 °C	[s]	ton ≤ 20 s, toff ≥ 50 s
PSINK = 105 W, Tamb = 25 °C	[s]	ton ≤ 30 s, toff ≥ 90 s
PSINK = 140 W, Tamb = 25 °C	[s]	ton ≤ 10 s, toff ≥ 40 s
PSINK = 140 W, Tamb = 25 °C	[s]	ton ≤ 20 s, toff ≥ 90 s
PSINK = 140 W, Tamb = 25 °C	[s]	ton ≤ 30 s, toff ≥ 170 s
Power derate above 25 °C	[%/°C]	2
<b>Protection</b>		Electronic power limit, over current
Max. sink current	[A]	65
Sink over voltage protection typical trip point (In case of higher sink current than the maximum current)	[V]	15.5 – 19.5
Thermal overload protection		In case of power sink thermal
<b>Recovery time / deviation</b>		GEN12.5-60 PSINK
<b>Load current switches from positive to negative</b>		
<b>Vout = 6 V, Iout = +20 A → -10 A</b>		
Deviation	[V]	0.4
Percentage	[%]	6.67
Recovery to 0.5 % or 100 mV whichever is greater	[ms]	5.5
<b>Vout = 12.5 V, Iout = +15 A → -5 A</b>		
Deviation	[V]	0.35
Percentage	[%]	2.8
Recovery to 0.5 % or 100 mV whichever is greater	[ms]	2.5
<b>Vout = 20 V, Iout = +12 A → -4 A</b>		
Deviation	[V]	
Percentage	[%]	
Recovery to 0.5 % or 100 mV whichever is greater	[ms]	
<b>Vout = 30 V, Iout = +10 A → -2 A</b>		
Deviation	[V]	
Percentage	[%]	
Recovery to 0.5 % or 100 mV whichever is greater	[ms]	



Recovery time / deviation Load current switches from positive to negative (750 W)		GEN12.5-60 PSINK
<b>Vout = 40 V, Iout = +8 A → -1 A</b>		
Deviation	[V]	
Percentage	[%]	
Recovery to 0.5 % or 100 mV whichever is greater	[ms]	
<b>Vout = 60 V, Iout = +5 A → -1 A</b>		
Deviation	[V]	
Percentage	[%]	
Recovery to 0.5 % or 100 mV whichever is greater	[ms]	
Programming down speed		12.5 → 0 V
Fall time (90 % – 10 %) (1*)	[ms]	< 3
Note 1: In case of Analog programming Fall time slew rate is 200 μs/1 V. Note 2: Values are typical at 25 °C		

**NEW** Specifications Genesys™ GEN 1500 W Power Sink (Option)

Specifications Power Sink (1500 W)		GEN12.5-120 PSINK
<b>Sink power rating</b>		
Max. peak power (thermal limited) Tamb = 25 °C	[W]	200
Max. peak power (thermal limited) Tamb = 50 °C	[W]	100
Max. sink peak power duration	[s]	30
Recovery time for max. peak power	[s]	900
Max. continues power, Tamb = 25 °C	[W]	55
Max. continues power, Tamb = 50 °C	[W]	35
Power derate above 25 °C	[%/°C]	1.5
<b>Duty cycle for use at peak power</b>		
PSINK = 80 W, Tamb = 25 °C	[s]	ton ≤ 10 s, toff ≥ 10 s
PSINK = 80 W, Tamb = 25 °C	[s]	ton ≤ 20 s, toff ≥ 21 s
PSINK = 80 W, Tamb = 25 °C	[s]	ton ≤ 30 s, toff ≥ 36 s
PSINK = 120 W, Tamb = 25 °C	[s]	ton ≤ 10 s, toff ≥ 22 s
PSINK = 120 W, Tamb = 25 °C	[s]	ton ≤ 20 s, toff ≥ 50 s
PSINK = 120 W, Tamb = 25 °C	[s]	ton ≤ 30 s, toff ≥ 90 s
PSINK = 160 W, Tamb = 25 °C	[s]	ton ≤ 10 s, toff ≥ 40 s
PSINK = 160 W, Tamb = 25 °C	[s]	ton ≤ 20 s, toff ≥ 90 s
PSINK = 160 W, Tamb = 25 °C	[s]	ton ≤ 30 s, toff ≥ 170 s
Power derate above 25 °C	[%/°C]	2
<b>Protection</b>		
Electronic power limit, over current		
Max. sink current	[A]	65
Sink over voltage protection typical trip point (In case of higher sink current than the maximum current)	[V]	15.5 – 19.5
Thermal overload protection		In case of power sink thermal
Recovery time / deviation Load current switches from positive to negative		GEN12.5-120 PSINK
<b>Vout = 6 V, Iout = +40 A → - 15 A</b>		
Deviation	[V]	0.5
Percentage	[%]	8.33
Recovery to 0.5 % or 100 mV whichever is greater	[ms]	5.5



Recovery time / deviation Load current switches from positive to negative (1500 W)		GEN12.5-120 PSINK
<b>Vout = 12.5 V, Iout = +30 A → -10 A</b>		
Deviation	[V]	0.4
Percentage	[%]	3.2
Recovery to 0.5 % or 100 mV whichever is greater	[ms]	2.5
<b>Vout = 20 V, Iout = +25 A → -8 A</b>		
Deviation	[V]	
Percentage	[%]	
Recovery to 0.5 % or 100 mV whichever is greater	[ms]	
<b>Vout = 30 V, Iout = +20 A → -3 A</b>		
Deviation	[V]	
Percentage	[%]	
Recovery to 0.5 % or 100 mV whichever is greater	[ms]	
<b>Vout = 40 V, Iout = +15 A → -2 A</b>		
Deviation	[V]	
Percentage	[%]	
Recovery to 0.5 % or 100 mV whichever is greater	[ms]	
<b>Vout = 60 V, Iout = +10 A → -1 A</b>		
Deviation	[V]	
Percentage	[%]	
Recovery to 0.5 % or 100 mV whichever is greater	[ms]	
<b>Programming down speed</b>		<b>12.5 → 0 V</b>
Fall time (90 % – 10 %)	[ms]	< 3
Note 1: In case of Analog programming Fall time slew rate is 200 $\mu$ s/1 V. Note 2: Values are typical at 25 °C		

GEN20-76 PSINK	GEN30-50 PSINK	GEN40-38 PSINK	GEN60-25 PSINK	
0.55	0.75	0.9		
4.4	6.0	7.2		
8	17.5	35		
0.5	0.75	0.9		
2.5	3.75	4.5		
6.5	15	28		
	0.7	0.75	0.7	
	2.33	2.5	2.33	
	10	15	13	
		0.75	0.7	
		1.88	1.75	
		12	8	
			0.55	
			0.92	
			6	
<b>20 → 0 V</b>	<b>30 → 0 V</b>	<b>40 → 0 V</b>	<b>60 → 0 V</b>	
< 3	< 3	< 3	< 3	No load

# Outline drawings Genesys™ GENH 750 W Units

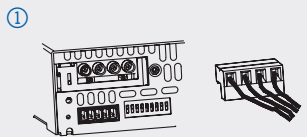
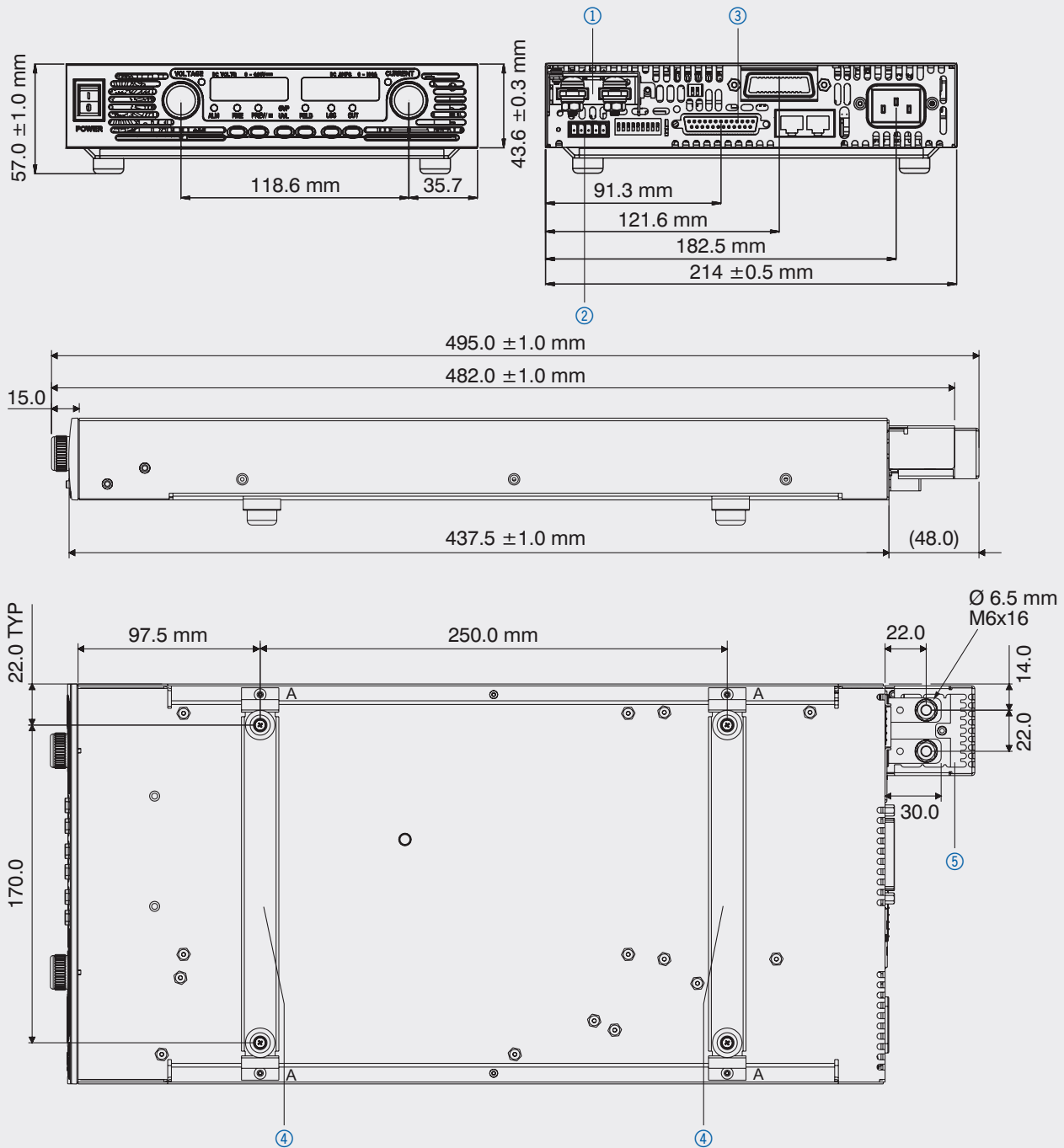

GENH Models 80 v to 600 V.

- ① Bus-bars 6V to 60V models  
Connector 80V to 600V model  
Header Phoenix P/N: GIC 2.5/4-G-7.62  
Mating plug Phoenix P/N: GIC 2.5/4-ST-7.62
- ② Mating plug Phoenix P/N: MC1.5/5-ST-3.81
- ③ Mating plug AMP P/N: 745211-2  
Mating plugs supplied with power supply.
- ④ Benchtop assembly x 2 (removable)  
Screws: 4 x M3x8 marked "A".  
Supplied with the power supply.
- ⑤ Bus Bars enclosure for 60V to 600V.

# Outline drawings Genesys™ GEN 750/1500 W Units

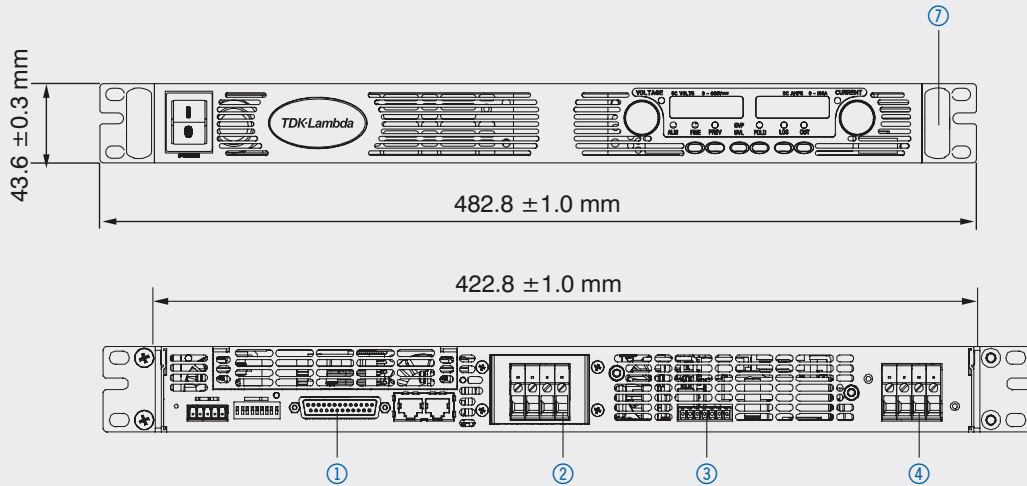

## Bus-Bar Detail 6 V to 60 V Models

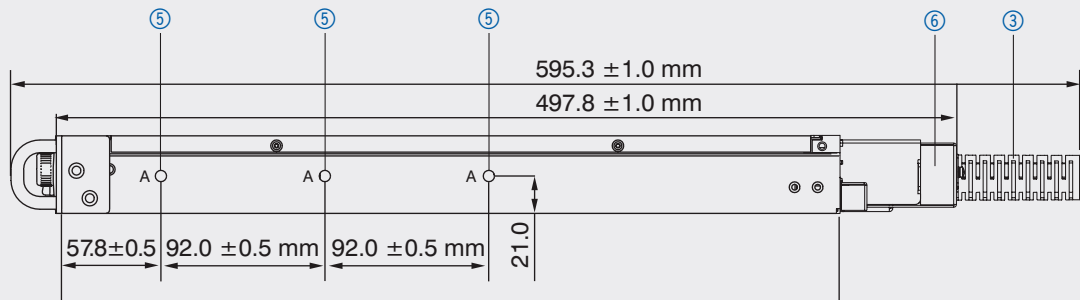
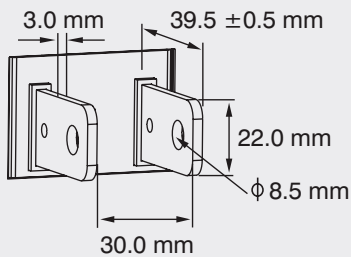

- ① Mating plug supplied with power supply.
- ② Bus-bars for 6 V to 60 V models. See detail. Wire clamp connector for 80 V to 600 V models (shown).
- ③ AC cable strain relief for 1500 W models only (supplied with power supply).
- ④ IEC connector for 750 W models. Wire clamp terminal for 1500 W models.
- ⑤ Chassis slides GENERAL DEVICES P/N: CC3001-00-S160 or equivalent, mounting holes #10-32 marked "A".
- ⑥ Bus Bars output connector enclosure for 60 V to 600 V.
- ⑦ Mounting holes for 19" rack. Use M 6x16 screws to fix the unit to the rack.

# Genesys™ GEN 2400 W in 1U 19" rack

Model	Output Voltage [V DC]	Output Current [A]	Output Power [W]
GEN8-300	0~8	0~300	2400
GEN10-240	0~10	0~240	2400
GEN16-150	0~16	0~150	2400
GEN20-120	0~20	0~120	2400
GEN30-80	0~30	0~80	2400
GEN40-60	0~40	0~60	2400
GEN60-40	0~60	0~40	2400
GEN80-30	0~80	0~30	2400
GEN100-24	0~100	0~24	2400
GEN150-16	0~150	0~16	2400
GEN300-8	0~300	0~8	2400
GEN600-4	0~600	0~4	2400

## How to order

### Power Supply Identification GEN 2400 W 1U

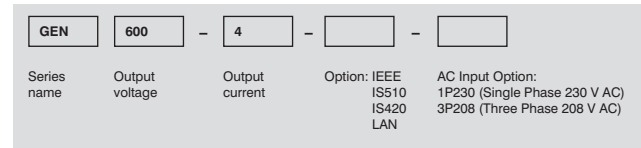

### Factory Option GEN 2400 W

RS-232/RS-485 Interface Built-in Standard	P/N: -
IEEE 488.2 (GPIB) Interface	IEEE
Voltage Programming Isolated Analog Interface	IS510
Current Programming Isolated Analog Interface	IS420
LAN Interface (Complies with <b>LXI</b> class C)	LAN

## Front panel description GEN 2400 W in 1U 19" rack

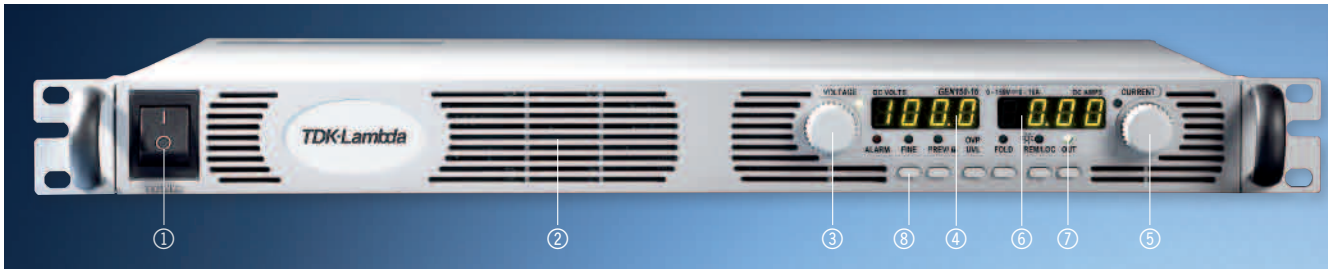

- ① ON/OFF Switch
- ② Air Intake allows zero stacking for maximum system flexibility and power density.
- ③ Reliable encoder controls Output Voltage and sets Address, OVP, UVL Limits.
- ④ Volt Display shows Output Voltage and directly displays OVP, UVL and Address settings.
- ⑤ Reliable encoder controls Output Current, sets Baud rate and Advanced Parallel Mode.
- ⑥ Current Display shows Output Current and displays Baud rate. Displays total current in Parallel Master/Slave Mode.
- ⑦ Function/Status LEDs:
  - Alarm
  - Fine Control
  - Preview Settings
  - Fold-back Mode
  - Remote Mode
  - Output On
- ⑧ Push-buttons allow flexible user configuration:
  - Coarse and Fine adjustment of Output Voltage/Current and Advanced Parallel Master/Slave Mode.
  - Preview settings and set Voltage/Current with Output OFF, Front Panel Lock.
  - Parallel Master/Slave
  - Set OVP and UVL Limits
  - Set Current Fold-back
  - Local/Remote Mode and select Address and Baud rate.
  - Output ON/OFF and Auto-Re-Start/Safe-Start Mode.

## Rear panel description GEN 2400 W in 1U 19" rack

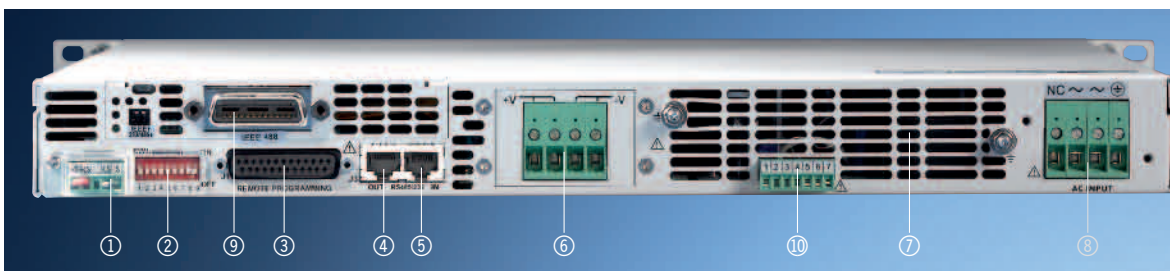

- ① Remote/Local Output Voltage Sense Connections.
- ② DIP Switches select 0–5 V or 0–10 V Programming and other functions.
- ③ DB25 (Female) connector allows (Non-isolated) Analog Program and Monitor and other functions.
- ④ RS-485 OUT to other Genesys™ Power Supplies.
- ⑤ RS-232/RS-485 IN Remote Serial Programming.
- ⑥ Output Connections:  
Rugged busbars for 8 ~ 100 V Output. Wire clamp terminal for output 150 to 600 V models (shown).
- ⑦ Exit air assures reliable operation when zero stacked.
- ⑧ Input:
  - 230 V AC Single-Phase (shown), 208 V AC Three Phase, 50/60 Hz
  - AC Input Connector: Phoenix P/N: FRONT-4-H-7.62.
- ⑨ Optional Interface Position for IEEE 488.2 SCPI (shown) or Isolated Analog Interface or LAN interface.
- ⑩ Auxiliary Output Voltage. 5 V/0.2 A (isolated), 15 V/0.2 A (non-isolated).

# Specifications Genesys™ GEN 2400 W

Model	GEN	8-300	10-240	16-150
Rated output voltage (*1)	[V]	8	10	16
Rated output current (*2)	[A]	300	240	150
Rated output power	[W]	2400	2400	2400
Efficiency (*3)	[%]	84	84	86
<b>Constant Current Mode</b>				
Max. line regulation (0.01 % of $I_o$ + 2 mA) (*4)	[mA]	32	26	17
Max. load regulation (0.02 % of $I_o$ + 5 mA) (*6)	[mA]	65	53	35
Ripple RMS 5 Hz~1 MHz (*10)	[mA]	1200	960	600
Temperature coefficient	[ppm/°C]	100 ppm/°C from rated output voltage, following		
<b>Constant Voltage Mode</b>				
Max. line regulation (0.01 % of $V_o$ + 2 mV) (*4)	[mV]	2.8	3	3.6
Max. load regulation (0.015 % of $V_o$ + 5 mV) (*5)	[mV]	6.2	6.5	7.4
Ripple and noise p-p 20 MHz (*9)	[mV]	60	60	60
Ripple RMS 5 Hz~1 MHz	[mV]	8	8	8
Remote sense compensation/line	[V]	2	2	2
Temperature coefficient	[ppm/°C]	100 ppm/°C of rated output voltage, following 30		
Up-prog. response time, 0~ $V_o$ Rated (*7)	[ms]	15		
Down-prog. response time full-load (*7)	[ms]	10		
Down-prog. response time no-load (*8)	[ms]	500		
Transient response time	[ms]	Time for output voltage to recover within 0.5 % Less than 1 ms for models up to and		
<b>Protective Functions</b>				
OCP		0~105 % Constant Current		
OCP Fold-back		Output shut-down when power supply change		
OVP type		Inverter shut-down, manual reset by AC input		
OVP trip point	[V]	0.5~10	0.5~12	1~19
Over Temperature Protection		User-selectable, latched or non-latched		

\*1: Minimum voltage is guaranteed to maximum 0.2 % of rated output voltage.

\*2: Minimum current is guaranteed to maximum 0.4 % of rated output current.

\*3: 3-Phase 208 V models: At 208 V AC input voltage. With rated output power.

\*4: 3-Phase 208 V models: 170~265 V AC, constant load.

\*5: From No-load to Full-load, constant input voltage.  
Maximum drop in Remote Sense.

\*6: For load voltage change, equal to the unit voltage rating,  
constant input voltage.

20-120	30-80	40-60	60-40	80-30	100-24	150-16	300-8	600-4
20	30	40	60	80	100	150	300	600
120	80	60	40	30	24	16	8	4
2400	2400	2400	2400	2400	2400	2400	2400	2400
87	87	88	88	88	88	88	88	88
14	10	8	6	5	4.4	3.6	2.8	2.4
29	21	17	13	11	9.8	8.2	6.6	5.8
480	220	120	70	50	40	30	15	7
30 minutes warm up								
4	5	6	8	10	12	17	32	62
8	9.5	11	14	17	20	27.5	50	95
60	60	60	60	80	80	100	150	300
8	8	8	8	10	10	25	50	75
2	5	5	5	5	5	5	5	5
minutes warm up								
		20	30	40	60	80	100	
20			30	50	80		100	
	600	700	1100	1200	1500	2500		3000
of its rated output for a load change 10~90 % of rated output current. Output set-point: 10~100 %, local sense. including 100 V. 2 ms for models above 100 V								
from CV to CC. User-selectable.								
recycle or by OUT button or by communication port.								
1~24	2~36	2~44	5~66	5~88	5~110	5~165	5~330	5~660

\*7: From 10 % to 90 % or 90 % to 10 % of rated output voltage, with rated, resistive load.

\*8: From 90 % to 10 % of rated output voltage.

\*9: For 8 V~300 V models: measured with JEITA RC-9131 1:1 probe.  
For 600 V model: measured with 10:1 probe.

\*10: For 8 V~16 V models the ripple is measured from 2 V to rated output voltage and rated output current. For other models, the ripple is measured at 10~100 % of rated output voltage and rated output current.

Sequel ►

Interface RS-232 & RS-485 or Optional GPIB / LAN Interface	GEN	8-400	10-330	15-220
Model	[V]	8	10	16
<b>Remote Current Programming (16 bit)</b>				
Resolution (0.012 % of I <sub>o</sub> Rated)	[mA]	36	28.8	18
Accuracy (0.2 % of I <sub>o</sub> Rated + 0.1 % of I <sub>o</sub> Actual Output) (*11)	[mA]	900	720	450
<b>Readback Current</b>				
Resolution (0.012 % of I <sub>o</sub> Rated)	[mA]	36	28.8	18
Accuracy (0.3 % of I <sub>o</sub> Rated + 0.1 % of I <sub>o</sub> Actual Output) (*11)	[mA]	1200	960	600
<b>Remote Voltage Programming (16 bit)</b>				
Resolution (0.012 % of V <sub>o</sub> Rated)	[mV]	0.96	1.2	1.92
Accuracy (0.05 % V <sub>o</sub> Rated + 0.05 % of V <sub>o</sub> Actual Output)	[mV]	8	10	16
<b>Readback Voltage</b>				
Resolution (0.012 % of V <sub>o</sub> Rated)	[mV]	0.96	1.2	1.92
Accuracy (0.1 % V <sub>o</sub> Rated + 0.1 % of V <sub>o</sub> Actual Output)	[mV]	16	20	32
<b>OVP/UVL Programming</b>				
Resolution (0.1 % of V <sub>o</sub> Rated)	[mV]	8	10	16
Accuracy (1 % of V <sub>o</sub> Rated)	[mV]	80	100	160

Analog Programming and Monitoring	
V <sub>out</sub> Voltage Programming	0~100 %, 0~5 V or 0~10 V, user-selectable. Accuracy and linearity: ± 0.5 % of rated V <sub>out</sub> .
I <sub>out</sub> Voltage Programming (*11)	0~100 %, 0~5 V or 0~10 V, user-selectable. Accuracy and linearity: ± 1 % of rated I <sub>out</sub> .
V <sub>out</sub> Resistor Programming	0~100 %, 0~5/10 kΩ full scale, user-selectable. Accuracy and linearity: ± 1 % of rated V <sub>out</sub> .
I <sub>out</sub> Resistor Programming (*11)	0~100 %, 0~5/10 kΩ full scale, user-selectable. Accuracy and linearity: ± 1.5 % of rated I <sub>out</sub> .
On/Off control (rear panel)	By electrical. Voltage: 0~0.6 V/2~15 V, or dry contact, user-selectable logic
Output current monitor (*11)	0~5 V or 0~10 V, accuracy: ± 1 %, user-selectable
Output voltage monitor	0~5 V or 0~10 V, accuracy: ± 1 %, user-selectable
Power supply OK signal	TTL high (4~5 V) -OK, 0 V-Fail, 500 Ω series resistance
CV/CC indicator	Open Collector, CC mode: On, CV mode: Off. Maximum voltage: 30 V, maximum sink current: 10 mA
Enable/Disable	Dry contact. Open: off, Short: on. Max. voltage at Enable/Disable in: 6 V
Local/Remote analog control	By electrical signal or Open/Short: 0~0.6 V or short: Remote, 2~5 V or open: Local
Local/Remote analog control indicator	Open collector, Local: Open, Remote: On. Maximum voltage: 30 V, maximum sink current: 10 mA

\*11: The Constant Current programming readback and monitoring accuracy does not include the warm-up and load regulation thermal drift.

20-165	30-110	40-85	60-55	80-42	100-33	150-22	300-11	600-5.5
20	30	40	60	80	100	150	300	600
14.4	9.6	7.2	4.8	3.6	2.88	1.92	0.96	0.48
360	240	180	120	90	72	48	24	12
14.4	9.6	7.2	4.8	3.6	2.88	1.92	0.96	0.48
480	320	240	160	120	96	64	32	16
2.4	3.6	4.8	7.2	9.6	12	18	36	72
20	30	40	60	80	100	150	300	600
2.4	3.6	4.8	7.2	9.6	12	18	36	72
40	60	80	120	160	200	300	600	1200
20	30	40	60	80	100	150	300	600
200	300	400	600	800	1000	1500	3000	6000

Front Panel	
Control functions	Vout/Iout manual adjust by separate encoders (coarse and fine adjustment selectable)
	OVP/UVL manual adjust by Volt. Adjust encoder
	AC on/off, Output on/off, Re-start modes (auto, safe), Fold-back control (CV to CC), go to local control
	Address selection by Voltage adjust encoder. Number of addresses: 31
	Baud rate selection: 1200, 2400, 4800, 9600 and 19200
Display	Voltage 4 digits, accuracy: 0.5 % of rated output voltage $\pm 1$ count
	Current 4 digits, accuracy: 0.5 % of rated output current $\pm 1$ count
Indications	Voltage, Current, Alarm, Fine, Preview, Fold-back, Remote (RS232/485, IEEEE), Output On, Front Panel Lock, CV/CC

Input Characteristics		8-300	10-240	16-150
Input voltage/freq. (*12)	[V AC]	Single-Phase, 230 V models: 170~265 V AC, 3-Phase, 208 V models: 170~265 V AC, 47~		
Maximum Input current at 100 % load Single-Phase, 230 V models 3-Phase, 208 V models	[A] [A]	17 10.5	17 10.5	17 10.5
Power Factor (Typ)		Single-Phase models: 0.99@230 V AC, rated 3-Phase models: 0.94@208 V AC, rated output		
Efficiency (*3)	[%]	84	84	86
Inrush current (*14)	[A]	Single-Phase and 3-Phase 208 V models: Less		
Hold-up time (Typ)	[ms]	10 ms for Single-Phase and 3-Phase 208 V		

\*3: At 200 V AC input voltage, with rated output power

\*12: For cases where conformance to various safety standards (UL, IEC, etc.) is required, to be described as 190 – 240 V AC (50/60 Hz) for 3-phase 208 V models.

\*14: Not including EMI filter inrush current, less than 0.2 ms.

Auxiliary Output	
15 V output	15 V $\pm$ 5 %, 0.2 A Max. load, Ripple & Noise 100 mV p-p. Referenced internally to the negative output potential.
5 V output	5 V $\pm$ 5 %, 0.2 A Max. load, Ripple & Noise 100 mV p-p. Referenced internally to IF_com potential.
Power Supply Configuration	
Parallel operation	Up to 4 identical units in master/slave mode
Series operation	Up to 2 identical units with external diodes. 600 V max. to chassis ground
Environmental Conditions	
Operating temperature	0~50 °C, 100 % load
Storage temperature	-20~85 °C
Operating humidity	20~90 % RH (non-condensing)
Storage humidity	10~95 % RH (non-condensing)
Vibration	MIL-810F, method 514.5, The EUT is fixed to the vibrating surface
Shock	Less than 20 g, half sine, 11 ms unit is unpacked
Altitude	Operating: 10,000 ft (3,000 m), Derate output current by 2 % / 100 m above 2,000 m. Alternatively, derate maximum ambient temperature by 1 °C / 100 m above 2,000 m. Non-operating: 40,000 ft (12,000 m)
RoHS Compliance	Complies with the requirements of RoHS directive.
EMC	
Applicable Standards:	
ESD	IEC1000-4-2. Air-disch. -8 kV, contact disch. -4 kV
Fast transients	IEC1000-4-4. 2 kV
Surge immunity	IEC1000-4-5. 1 kV line to line, 2 kV line to ground
Conducted immunity	IEC1000-4-6, 3 V
Radiated immunity	IEC1000-4-3, 3 V/m
Magnetic field immunity	EN610000-4-8, 1A/m
Voltage dips	EN61000-4-11
Conducted emission	EN55022A, FCC part 15-A, VCCI-A
Radiated emission	EN55022A, FCC part 15-A, VCCI-A

20-120	30-80	40-60	60-40	80-30	100-24	150-16	300-8	600-4
47–63 Hz 63 Hz								
16.3 9.8	16.3 9.8	16.3 9.8	16.3 9.8	16.3 9.8	16.3 9.8	16.3 9.8	16.3 9.8	16.3 9.8
output power. power								
87	87	88	88	88	88	88	88	88
than 50 A								
models. Rated output power								

Safety	
Applicable standards	CE Mark, UL 60950-1 listed, ICE 60950-1 CB, EN 60950-1:2006 (Edition 2) + A 11: 2009, classified GS. Vout ≤40 V: Output is SELV, IEEE/Isolated analog are SELV 40 <Vout ≤400 V: Output is hazardous, IEEE/Isolated analog are SELV 400 <Vout ≤600 V: Output is hazardous, IEEE/Isolated analog are not SELV
Withstand voltage	Vout ≤40 V models: Input-Outputs (SELV): 4242 V DC 1min, Input-Ground: 2828 V DC 1 min 40 <Vout ≤100 V models: Input-Haz. Output: 2600 V DC 1min, Input-SELV: 4242 V DC 1 min Hazardous Output-SELV: 1900 V DC 1 min, Hazardous Output-Ground: 1200 V DC 1 min, Input-Ground: 2828 V DC 1 min 100 <Vout ≤600 V models: Input-Haz. Output: 4000 V DC 1min, Input-SELV: 4242 V DC 1 min Hazardous Output-SELV: 3550 V DC 1 min, Hazardous Output-Ground: 2670 V DC 1 min, Input-Ground: 2828 V DC 1 min
Insulation resistance	More than 100 MΩ at 25 °C, 70 % RH
Mechanical Construction	
Cooling	Forced air flow: from front to rear. No ventilation holes at the top or bottom of the chassis; Variable fan speed.
Dimensions (WxHxD)	W: 423.0 mm, H: 43.6 mm, D: 441 mm (excluding connectors, encoders, handles, etc.)
Weight	10 kg
AC Input connector (with Protective Cover)	Single-Phase, 230 V models, wire clamp connenctor, Phoenix P/N: FRONT-4-H-7.62, with Stain relief 3-Phase, 208 V models, wire clamp connenctor, Phoenix P/N: FRONT-4-H-7.62, with Stain relief
Output connectors	8 V to 100 V models: Bus-bars (hole Ø 8.5 mm). 150 V to 600 V models: wire clamp connector, Phoenix P/N: FRONT-4-H-7.62 Auxiliary output header: IMC 1.5/7-G-3.81, Plug: IMC 1.5/7-ST-3.81 (Phoenix Contact)
Reliability specs	
Warranty	5 years

Sequel ►

All specifications subject to change without notice.

# Outline drawings Genesys™ GEN 2400 W Units

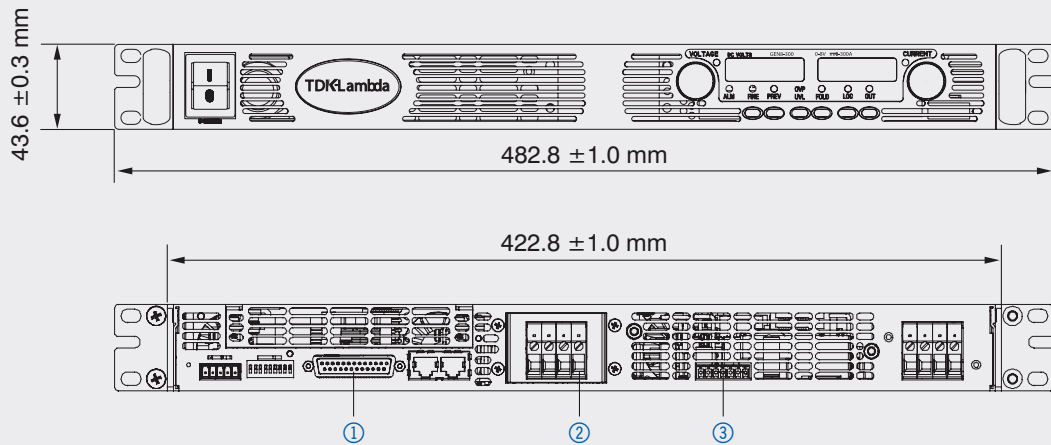

## Bus-Bar Detail 8 V to 100 V Models

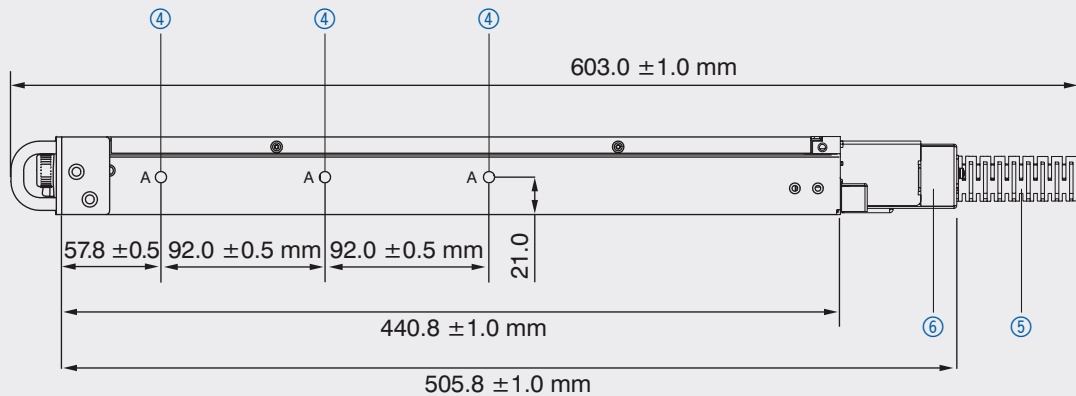
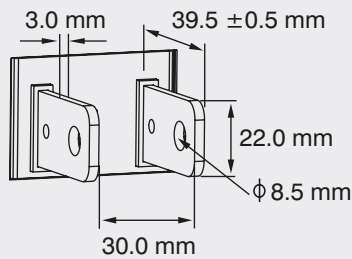

- ① Mating plug supplied with power supply.
- ② DC output:  
Bus-bars for 8 V to 100 V models, wire clamp terminal for 150 V to 600 V models.
- ③ Auxiliary output. Mating plug P/N: IMC 1.5/7-ST-3.8.1 Phoenix.
- ④ Chassis slides: GENERAL DEVICES P/N: CC3001-00-S160 or equivalent mounting holes #10-32 marked "A".
- ⑤ AC cable strain relief supplied with power supply.
- ⑥ Bus-bars enclosure for 60 V ~ 600 V.



# Genesys™ GEN 3.3 kW in 2U 19" rack

Model	Output Voltage [V DC]	Output Current [A]	Output Power [W]
GEN8-400	0~8	0~400	3200
GEN10-330	0~10	0~330	3300
GEN15-220	0~15	0~220	3300
GEN20-165	0~20	0~165	3300
GEN30-110	0~30	0~110	3300
GEN40-85	0~40	0~85	3400
GEN60-55	0~60	0~55	3300
GEN80-42	0~80	0~42	3360
GEN100-33	0~100	0~33	3300
GEN150-22	0~150	0~22	3300
<b>NEW</b> GEN200-16.5	0~200	0~16.5	3300
GEN300-11	0~300	0~11	3300
GEN600-5.5	0~600	0~5.5	3300

## How to order

### Power Supply Identification GEN 3.3 kW 2U

GEN	8	-	400	-		-	
Series name	Output voltage (0~8 V)	Output current (0~400 A)	Option: IEEE IS510 IS420 LAN	AC Input Options: 1P230 (Single Phase 230 V AC) 3P208 (Three Phase 208 V AC) 3P400 (Three Phase 400 V AC)			

### Factory Option GEN 3.3 kW

	P/N:
RS-232/RS-485 Interface Built-in Standard	-
IEEE 488.2 (GPIB) Interface	IEEE
Voltage Programming Isolated Analog Interface	IS510
Current Programming Isolated Analog Interface	IS420
LAN Interface (Complies with <b>LXI</b> class C)	LAN

## Front panel description GEN 3.3 kW in 2U 19" rack

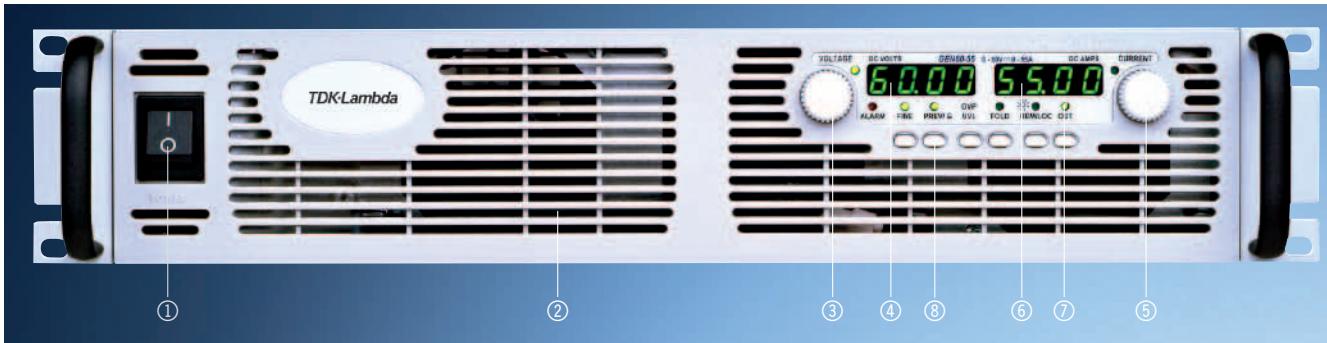

- ① ON/OFF Switch
- ② Air Intake allows zero stacking for maximum system flexibility and power density.
- ③ Reliable encoder controls Output Voltage and sets Address, OVP and UVL Limits.
- ④ Volt Display shows Output Voltage and directly displays OVP, UVL and Address settings.
- ⑤ Reliable encoder controls Output Current, sets Baud rate and Advanced Parallel Mode.
- ⑥ Current Display shows Output Current and displays Baud rate. Displays total current in Parallel Master/Slave Mode.
- ⑦ Function/Status LEDs:
  - Alarm
  - Fine Control
  - Preview Settings
  - Fold-back Mode
  - Remote Mode
  - Output On
- ⑧ Push-buttons allow flexible user configuration:
  - Coarse and Fine adjustment of Output Voltage/Current and Advanced Parallel Master or Slave.
  - Preview settings and set Voltage/Current with Output OFF, Front Panel Lock
  - Parallel Master/Slave
  - Set OVP and UVL Limits
  - Set Current Fold-back Protection
  - Local/Remote Mode and select Address and Baud rate
  - Output ON/OFF and Auto-Re-Start/Safe-Start Mode

## Rear panel description GEN 3.3 kW in 2U 19" rack

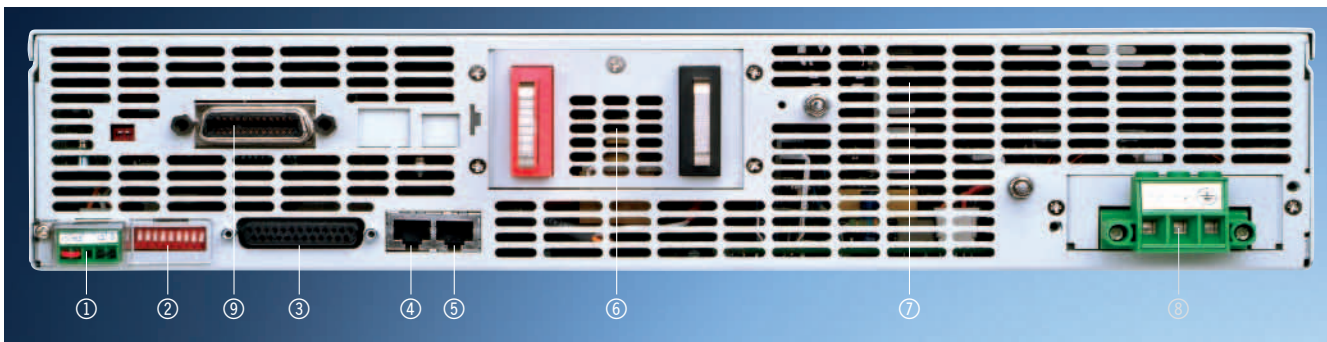

- ① Remote/Local Output Voltage Sense Connections.
- ② DIP Switches select 0–5 V or 0–10 V Programming and other functions.
- ③ DB25 (Female) connector allows (Non-isolated) Analog Program and Monitor and other functions.
- ④ RS-485 OUT to other Genesys™ Power Supplies.
- ⑤ RS-232/RS-485 IN Remote Serial Programming.
- ⑥ Output Connections:
  - Rugged busbars (shown) for up to 100 V output
  - Wire clamp connector for outputs > 100 V
- ⑦ Exit air assures reliable operation when zero stacked.
- ⑧ Input: 230 V AC Single-Phase (shown), 208 & 400 V AC Three Phase, 50/60 Hz AC Input Connector: PHOENIX CONTACT Power Combicon PC 6/... Series with strain relief.
- ⑨ Optional Interfaces Position for IEEE 488.2 SCPI (shown) or Isolated Analog Interface or LAN interface.

# Specifications Genesys™ GEN 3.3 kW

Model	GEN	8-400	10-330	15-220
Rated output voltage (*1)	[V]	8	10	15
Rated output current (*2)	[A]	400	330	220
Rated output power	[W]	3200	3300	3300
<b>Constant Current Mode</b>				
Max. line regulation (0.01 % of rated I <sub>o</sub> + 2 mA) (*3)	[mA]	42	35	24
Max. load regulation (0.02 % of rated I <sub>o</sub> + 5 mA) (*8)	[mA]	85	71	49
Ripple RMS 5 Hz~1 MHz (*9)	[mA]	1300	1200	880
Load regulation thermal drift		Less than 0.1 % of rated output current		
Temperature coefficient	[ppm/°C]	100 ppm/°C from rated output current,		
Temperature stability		0.05 % of rated I <sub>out</sub> over 8 hrs interval		
Warm-up drift		8~20 V model: Less than ±0.5 % rated 30~600 V model: Less than ±0.25 % of		
<b>Constant Voltage Mode</b>				
Max. line regulation (0.01 % of rated V <sub>o</sub> + 2 mV) (*3)	[mV]	2.8	3	3.5
Max. load regulation (0.015 % of rated V <sub>o</sub> + 5 mV) (*4)	[mV]	6.2	6.5	7.25
Ripple and noise p-p 20 MHz (*5)	[mV]	60	60	60
Ripple RMS 5 Hz~1 MHz	[mV]	8	8	8
Remote sense compensation/wire	[V]	2	2	2
Temperature coefficient	[ppm/°C]	100 ppm/°C of rated output voltage,		
Temperature stability		0.05 % of rated V <sub>out</sub> over 8 hrs interval		
Warm-up drift		Less than 0.05 % of rated output voltage		
Up-prog. response time, 0~V <sub>o</sub> Rated (*6)	[ms]			
Down-prog. response time	Full-load (*6)	[ms]	20	100
	No-load (*7)	[ms]	500	600
Transient response time	[ms]	Time for output voltage to recover within Output set-point: 10 – 100 %, local sense.		
<b>Protective Functions</b>				
OCP		0~105 % Constant Current		
OCP Fold-back		Output shut-down when power supply		
OVP type		Inverter shut-down, manual reset by AC		
OVP trip point	[V]	0.5~10	0.5~12	1~18
Output under voltage limit		Preset by front panel or communication		
Over Temperature Protection		User-selectable, latched or non-latched		

\*1: Minimum voltage is guaranteed to maximum 0.2 % of rated output voltage.

\*2: Minimum current is guaranteed to maximum 0.4 % of rated output current.

\*3: Single-Phase and 3-Phase 208 V models: 170~265 V AC, constant load.  
3-Phase 400 V models: 342~460 V AC, constant load.

\*4: From No-Load to Full-Load, constant input voltage. Maximum drop in Remote Sense.

\*5: For 8 V~300 V models: Measured with JEITA RC-9131A (1:1) probe.  
For 600 V model: Measured with 10:1 probe.

\*6: From 10 % to 90 % or 90 % to 10 % of Rated Output Voltage, with rated, resistive load.

\*7: From 90 % to 10 % of Rated Output Voltage.

20-165	30-110	40-85	60-55	80-42	100-33	150-22	200-16.5	300-11	600-5.5
20	30	40	60	80	100	150	200	300	600
165	110	85	55	42	33	22	16.5	11	5.5
3300	3300	3400	3300	3360	3300	3300	3300	3300	3300

18.5	13	10.5	7.5	6.2	5.3	4.2	3.65	3.1	2.6
38	27	22	16	13.4	11.6	9.4	8.3	7.2	6.1
660	300	200	100	80	70	60	40	20	10

over 30 minutes following load change.

following 30 minutes warm-up.

following 30 minutes warm-up. Constant line, load & temperature.

output current over 30 minutes following power On.  
rated output current over 30 minutes following power On.

4	5	6	8	10	12	17	22	32	62
8	9.5	11	14	17	20	27.5	35	50	95
60	60	60	60	80	100	100	275	300	500
8	8	8	8	25	25	25	75	100	120
2	5	5	5	5	5	5	5	5	5

following 30 minutes warm-up.

following 30 minutes warm-up. Constant line, load & temperature.

+ 2 mV over 30 minutes following power On.

80			150				200		250	
160				300						500
800	900	1000	1100	1200	1500	2000	3000	3500	4000	

0.5 % of its rated output for a load change 10 – 90 % of rated output current.  
Less than 1 ms for models up to and including 100 V. 2 ms for models above 100 V.

--	--	--	--	--	--	--	--	--	--

change from CV to CC. User-selectable.

input recycle or by OUT button or by communication port command.

1~24	2~36	2~44	5~66	5~88	5~110	5~165	5~220	5~330	5~660
------	------	------	------	------	-------	-------	-------	-------	-------

port. Prevents from adjusting Vout below limit.

Sequel ►

\*8: For load voltage change, equal to the unit voltage rating, constant input voltage.

\*9: For 8 V–15 V models the ripple is measured from 2 V to rated output voltage and rated output current. For other models, the ripple is measured at 10–100 % of rated output voltage and rated output current.

Interface RS-232 & RS-485 or Optional GPIB / LAN Interface	GEN	8-400	10-330	15-220
Model	[V]	8	10	15
<b>Remote Current Programming (16 bit)</b>				
Resolution (0.012 % of Io Rated)	[mA]	48	39.6	26.4
Accuracy (0.2 % of Io Rated + 0.1 % of Io Actual Output) (*10)	[mA]	1200	990	660
<b>Readback Current</b>				
Resolution (0.012 % of Io Rated)	[mA]	48	39.6	26.4
Accuracy (0.3 % of Io Rated + 0.1 % of Io Actual Output) (*10)	[mA]	1600	1320	880
<b>Remote Voltage Programming (16 bit)</b>				
Resolution (0.012 % of Vo Rated)	[mV]	0.96	1.2	1.8
Accuracy (0.05 % Vo Rated + 0.05 % of Vo Actual Output)	[mV]	8	10	15
<b>Readback Voltage</b>				
Resolution (0.012 % of Vo Rated)	[mV]	0.96	1.2	1.8
Accuracy (0.1 % Vo Rated + 0.1 % of Vo Actual Output)	[mV]	16	20	30
<b>OVP/UVL Programming</b>				
Resolution (0.1 % of Vo Rated)	[mV]	8	10	15
Accuracy (1 % of Vo Rated)	[mV]	80	100	150

Analog Programming and Monitoring	
Vout Voltage Programming	0~100 %, 0~5 V or 0~10 V, user-selectable. Accuracy and linearity: $\pm 0.5$ % of rated Vout.
Iout Voltage Programming (*10)	0~100 %, 0~5 V or 0~10 V, user-selectable. Accuracy and linearity: $\pm 1$ % of rated Iout.
Vout Resistor Programming	0~100 %, 0~5/10 k $\Omega$ full scale, user-selectable. Accuracy and linearity: $\pm 1$ % of rated Vout.
Iout Resistor Programming (*10)	0~100 %, 0~5/10 k $\Omega$ full scale, user-selectable. Accuracy and linearity: $\pm 1.5$ % of rated Iout.
On/Off control (rear panel)	By electrical. Voltage: 0~0.6 V/2~15 V, or dry contact, user-selectable logic
Output current monitor (*10)	0~5 V or 0~10 V, accuracy: $\pm 1$ %, user-selectable
Output voltage monitor	0~5 V or 0~10 V, accuracy: $\pm 1$ %, user-selectable
Power supply OK signal	TTL high (2~15 V) -OK, 0 V-Fail 500 $\Omega$ series resistance
CV/CC indicator	Open collector. CC mode: On, CV mode: Off. Maximum voltage: 30 V, maximum sink current: 10 mA.
Enable/Disable	Dry contact. Open: off, Short: on. Max. voltage at Enable/Disable in: 6 V
Local/Remote analog control	By electrical signal or Open/Short: 0~0.6 V or short: Remote, 2~15 V or open: Local
Local/Remote analog control indicator	Open collector, Local: Open, Remote: On. Maximum voltage: 30 V, maximum sink current: 10 mA

\*10: The Constant Current programming readback and monitoring accuracy does not include the warm-up and Load regulation thermal drift.

20-165	30-110	40-85	60-55	80-42	100-33	150-22	200-16.5	300-11	600-5.5
20	30	40	60	80	100	150	200	300	600
19.8	13.2	10.2	6.6	5.0	4.0	2.6	2.0	1.3	0.7
495	330	255	165	126	99	66	49.5	33	16.5
19.8	13.2	10.2	6.6	5.0	4.0	2.6	2.0	1.3	0.7
660	440	340	220	168	132	88	49.5	44	22
2.4	3.6	4.8	7.2	9.6	12	18	24	36	72
20	30	40	60	80	100	150	200	300	600
2.4	3.6	4.8	7.2	9.6	12	18	24	36	72
40	60	80	120	160	200	300	400	600	1200
20	30	40	60	80	100	150	200	300	600
200	300	400	600	800	1000	1500	2000	3000	6000

Front Panel	
Control functions	Vout/Iout manual adjust by separate encoders (coarse and fine adjustment selectable)
	OVP/UVL manual adjust by Volt. Adjust encoder
	AC on/off, Output on/off, Re-start modes (auto, safe), Fold-back control (CV to CC), Go to local control
	Address selection by Voltage (or current) adjust encoder. Number of addresses: 31
	Re-start modes (automatic re-start, safe mode)
	Baud rate selection: 1200, 2400, 4800, 9600 and 19200
Display	Voltage: 4 digits, Accuracy: 0.5 % of rated output voltage $\pm 1$ count
	Current: 4 digits, Accuracy: 0.5 % of rated output current $\pm 1$ count
Indications	Voltage, Current, Alarm, Fine, Preview, Fold-back, Local, Output On, Front Panel Lock, CV/CC

Input Characteristics		GEN	8-400	10-330	15-220
Input voltage/freq. (*1)		[V AC]	Single-Phase, 230 V models: 170~265 V AC, 47~63 Hz		
Maximum Input current at 100 % load	Single-Phase, 230 V models	[A]	24	24	24
	3-Phase, 208 V models	[A]	15	15	15
	3-Phase, 400 V models	[A]	7.5	7.5	7.5
Power Factor (Typ)			Single-Phase models: 0.99@230 V AC		
Inrush peak current (*2)		[A]	Single-Phase models: Less than 50 A		
Efficiency at 208 V and 400 V (*3)		[%]	82	83	83
Hold-up time		[ms]	10 ms for Single-Phase		

Power Supply Configuration	
Parallel operation	Up to 4 identical units in master/slave mode
Series operation	Up to 2 identical units with external diodes. 600 V max. to chassis ground
Environmental Conditions	
Operating temperature	0~50 °C, 100 % load
Storage temperature	-20~85 °C
Operating humidity	20~90 % RH (non-condensing)
Storage humidity	10~95 % RH (non-condensing)
Vibration	MIL-810F, method 514.5, The EUT is fixed to the vibrating surface
Shock	Less than 20 g, half sine, 11 ms unit is unpacked
Altitude	Operating: 10,000 ft (3,000 m), Derate output current by 2 % / 100 m above 2,000 m. Alternatively, derate maximum ambient temperature by 1 °C / 100 m above 2,000 m. Non-operating: 40,000 ft (12,000 m)
RoHS Compliance	Complies with the requirements of RoHS directive.
EMC	
Applicable Standards:	
ESD	IEC1000-4-2. Air-disch. -8 kV, contact disch. -4 kV
Fast transients	IEC1000-4-4. 2 kV
Surge immunity	IEC1000-4-5. 1 kV line to line, 2 kV line to ground
Conducted immunity	IEC1000-4-6, 3 V
Radiated immunity	IEC1000-4-3, 3 V/m
Magnetic field immunity	EN61000-4-8, 1A/m
Voltage dips	EN61000-4-11
Conducted emission	EN55022A, FCC part 15-A, VCCI-A
Radiated emission	EN55022A, FCC part 15-A, VCCI-A

\*1: For cases where conformance to various safety standards (UL, IEC, etc.) is required, to be described as 190 – 240 V AC (50/60 Hz) for Single-Phase and 3-Phase 208 V models, and 380~415 V AC (50/60 Hz) for 3-Phase 400 V models.

\*2: Not including EMI filter inrush current, less than 0.2 ms.

\*3: Single-Phase and 3-Phase 208 V models: At 280 V AC input voltage, 3-Phase 400 V: At 380 V AC input voltage. With rated output power.

20-165	30-110	40-85	60-55	80-42	100-33	150-22	200-16.5	300-11	600-5.5
3-Phase, 208 V models: 170~265 V AC, 47~63 Hz									
3-Phase, 400 V models: 342~460 Vac, 47~63 Hz									
24	24	24	23	23	23	23	23	23	23
15	15	15	14.5	14.5	14.5	14.5	14.5	14.5	14.5
7.5	7.5	7.5	7	7	7	7	7	7	7
3-Phase models: 0.94@208/400 V AC, (at 100 % load)									
3-Phase 208 V models: Less than 50 A									
3-Phase 400 V models: Less than 20 A									
83	86	86	88	88	88	87	87	87	87
3-Phase 208 V models, 10 ms									
3-Phase 400 V models. 6 ms Rated output power.									

Safety	
Applicable standards	CE Mark, UL 60950-1 listed, ICE 60950-1 CB, EN 60950-1:2006 (Edition 2) + A 11: 2009, classified GS. Vout ≤40 V: Output is SELV, IEEE/Isolated analog are SELV 40 <Vout ≤400 V: Output is hazardous, IEEE/Isolated analog are SELV 400 <Vout ≤600 V: Output is hazardous, IEEE/Isolated analog are not SELV
Withstand voltage	Vout ≤40 V models: Input-Outputs (SELV): 4242 V DC 1 min, Input-Ground: 2828 V DC 1 min 40 <Vout ≤100 V models: Input-Haz. Output: 2600 V DC 1 min, Input-SELV: 4242 V DC 1 min Hazardous Output-SELV: 1900 V DC 1 min, Hazardous Output-Ground: 1200 V DC 1 min, Input-Ground: 2828 V DC 1 min 100 <Vout ≤600 V models: Input-Haz. Output: 4000 V DC 1 min, Input-SELV: 4242 V DC 1 min Hazardous Output-SELV: 3550 V DC 1 min, Hazardous Output-Ground: 2670 V DC 1 min, Input-Ground: 2828 V DC 1 min
Insulation resistance	More than 100 MΩ at 25 °C, 70 % RH
Mechanical Construction	
Cooling	Forced air flow: from front to rear. No ventilation holes at the top or bottom of the chassis; Variable fan speed.
Dimensions (WxHxD)	W: 423.0 mm, H: 88 mm, D: 442.5 mm (excluding connectors, encoders, handles, etc.)
Weight	13 kg
AC Input connector (with Protective Cover)	Single-Phase, 230 V models, Power Combicon PC 6-16/3-GF-10, 16 series, with Strain relief. 3-Phase, 208 V & 400 V models, Power Combicon PC 6-16/4-GF-10, 16 series, with Strain relief.
Output connectors	8 V to 100 V models: Bus-bars (hole Ø 10.5 mm). 150 V to 600 V models: wire clamp connector, Phoenix P/N: FRONT-4-H-7.62
Reliability specs	
Warranty	5 years

All specifications subject to change without notice.

# Outline drawings Genesys™ GEN 3.3 kW Units

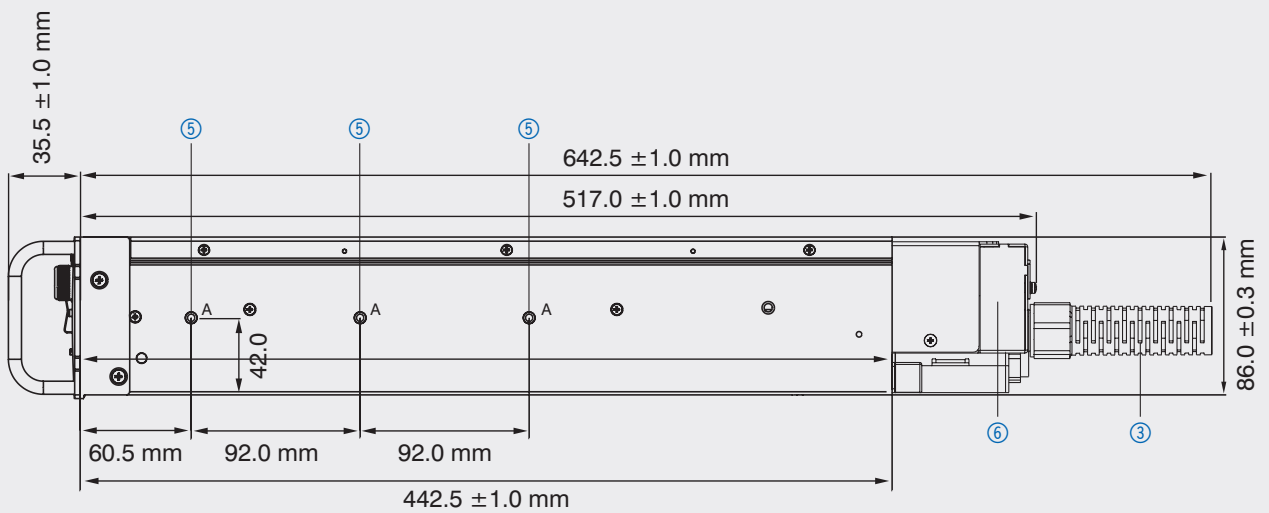
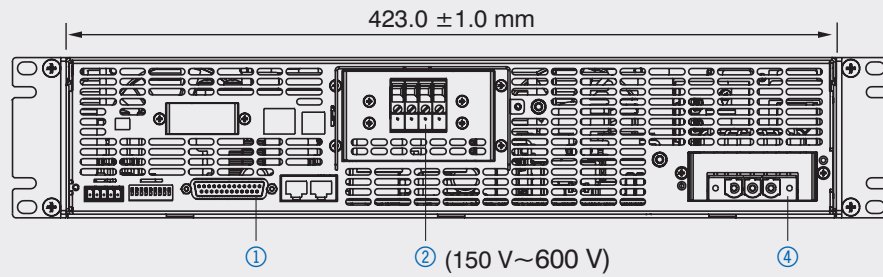
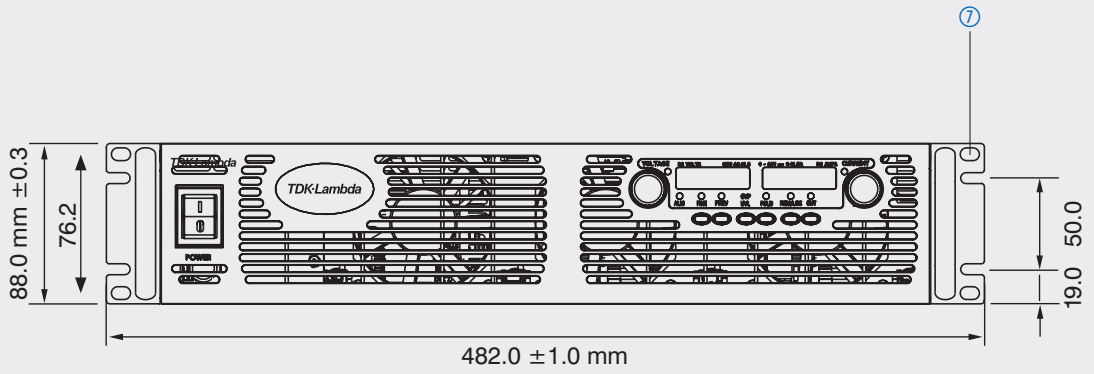

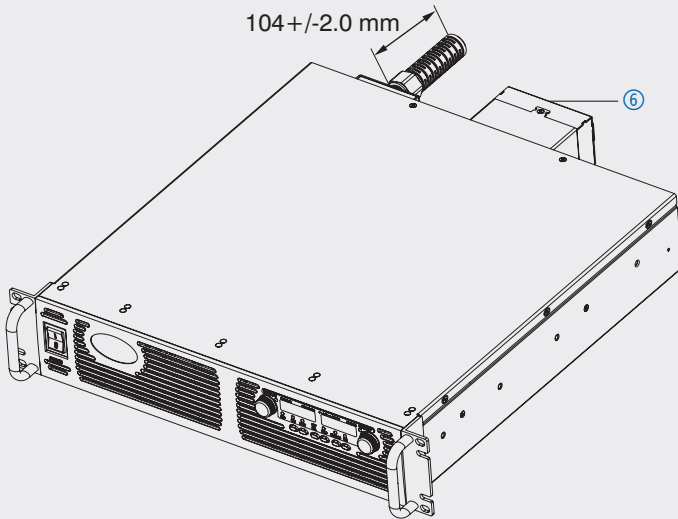

② **Bus-Bar Detail**  
8 V to 100 V Models

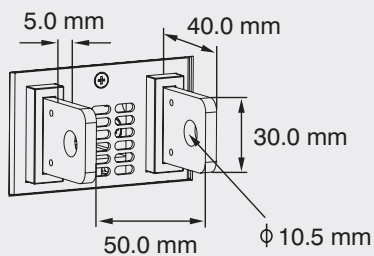

- ① Analog programming connector. Mating plug supplied with power supply.
- ② Bus-bars for 8 V to 100 V models. See detail. Wire clamp connector for 150 V to 600 V models (shown).
- ③ AC cable strain relief (supplied with power supply).
- ④ AC input connector (Single-Phase shown).
- ⑤ Chassis slides, GENERAL DEVICES P/N: CC3001-00-S160 or equivalent, mounting holes #10-32 marked "A".
- ⑥ Bus Bars enclosure for 60 V to 600 V.
- ⑦ Mounting holes for 19" rack. Use M6x16 screws to fix the unit to the rack.

# Genesys™ GEN 5 kW in 2U 19" rack

Model	Output Voltage [V DC]	Output Current [A]	Output Power [W]
GEN8-600	0~8	0~600	4800
GEN10-500	0~10	0~500	5000
GEN16-310	0~16	0~310	4960
GEN20-250	0~20	0~250	5000
GEN30-170	0~30	0~170	5100
GEN40-125	0~40	0~125	5000
GEN60-85	0~60	0~85	5100
GEN80-65	0~80	0~65	5200
GEN100-50	0~100	0~50	5000
GEN150-34	0~150	0~34	5100
<b>NEW</b> GEN200-25	0~200	0~25	5000
GEN300-17	0~300	0~17	5100
<b>NEW</b> GEN400-13	0~400	0~13	5200
<b>NEW</b> GEN500-10	0~500	0~10	5000
GEN600-8.5	0~600	0~8.5	5100

## How to order

### Power Supply Identification GEN 5 kW 2U

GEN	10	-	500	-		-	
Series name	Output voltage (0~10 V)		Output current (0~500 A)		Option: IEEE IS510 IS420 LAN		AC Input Options: 3P208 (Three Phase 208 V AC) 3P400 (Three Phase 400 V AC)

### Factory Option GEN 5 kW

	P/N:
RS-232/RS-485 Interface Built-in Standard	-
IEEE 488.2 (GPIB) Interface	IEEE
Voltage Programming Isolated Analog Interface	IS510
Current Programming Isolated Analog Interface	IS420
LAN Interface (Complies with <b>LXI</b> class C)	LAN

## Front panel description GEN 5 kW in 2U 19" rack

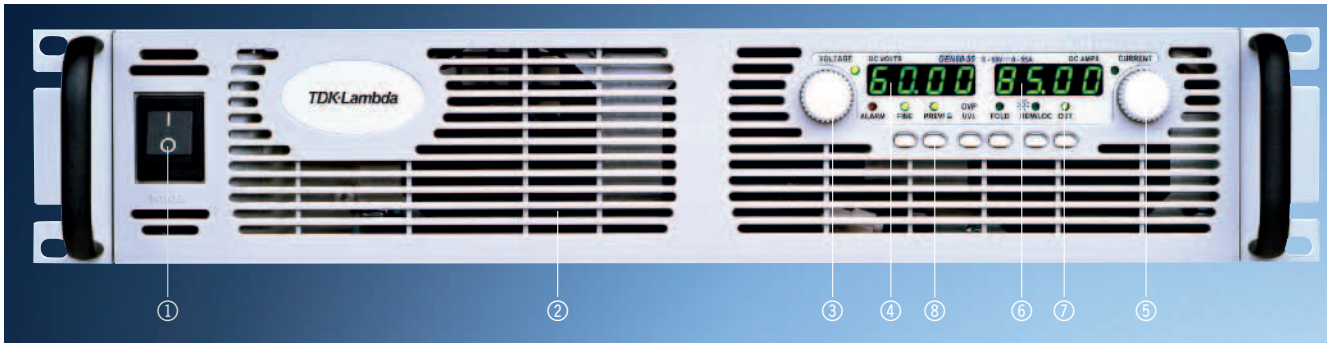

- ① ON/OFF Switch
- ② Air Intake allows zero stacking for maximum system flexibility and power density.
- ③ Reliable encoder controls Output Voltage, OVP and UVL settings.
- ④ Volt Display shows Output Voltage, Address, OVP and UVL settings.
- ⑤ Reliable encoder controls Output Current, sets Baud rate and Advanced Parallel Mode.
- ⑥ Current Display shows Output Current and displays Baud rate. Displays total current in Parallel Master/Slave Mode.
- ⑦ Function/Status LEDs:
  - Alarm
  - Fine Control
  - Preview Settings
  - Fold-back Mode
  - Remote Mode
  - Output On
- ⑧ Push-buttons allow flexible user configuration:
  - Coarse and Fine adjustment of Output Voltage/Current and Advanced Parallel Master or Slave.
  - Preview settings and set Voltage/Current with Output OFF, Front Panel Lock
  - Parallel Master/Slave
  - Set OVP and UVL Limits
  - Set Current Fold-back Protection
  - Local/Remote Mode and select Address and Baud rate
  - Output ON/OFF and Auto-Re-Start/Safe-Start Mode

## Rear panel description GEN 5 kW in 2U 19" rack

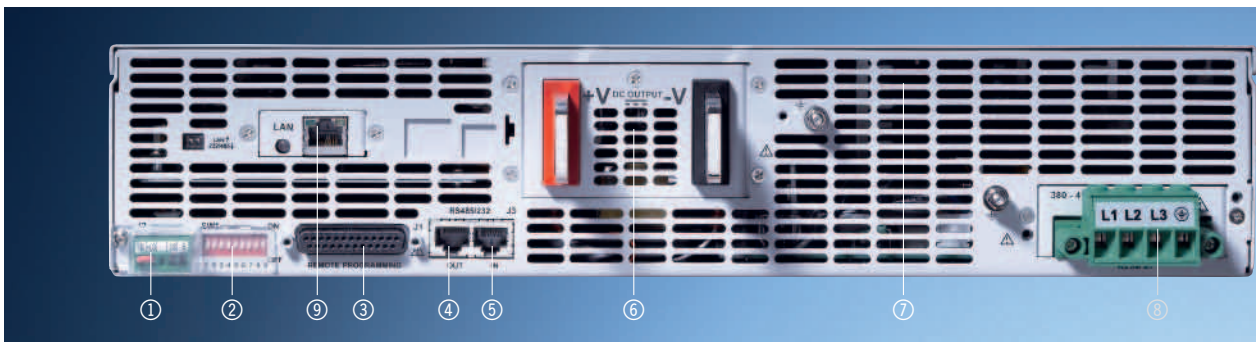

- ① Remote/Local Output Voltage Sense Connections.
- ② DIP Switches select 0–5 V or 0–10 V Programming and other functions.
- ③ DB25 (Female) connector allows (Non-isolated) Analog Program and Monitor and other functions.
- ④ RS-485 OUT to other Genesys™ Power Supplies.
- ⑤ RS-232/RS-485 IN Remote Serial Programming.
- ⑥ Output Connections:
  - Rugged busbars (shown) for up to 100 V output
  - Wire clamp connector for outputs 150 to 600 V
- ⑦ Exit air assures reliable operation when zero stacked.
- ⑧ Input:
  - 208 & 400 V AC Three Phase 50/60 Hz
  - AC input connector (supplied with plug-in connector). Header P/N: PC6-16/4-GF-10, 16 Phoenix contact
- ⑨ Optional Interface Position for IEEE 488.2 (SCPI), Isolated Analog Interface or LAN interface (shown).

# Specifications Genesys™ GEN 5 kW

Model	GEN	8-600	10-500	16-310	20-250
Rated output voltage (*1)	[V]	8	10	16	20
Rated output current (*2)	[A]	600	500	310	250
Rated output power	[W]	4800	5000	4960	5000
<b>Constant Current Mode</b>					
Max. line regulation (0.05 % of rated Io) (*3)	[mA]	300	250	155	125
Max. load regulation (0.1 % of rated Io) (*8)	[mA]	600	500	310	250
Ripple RMS 5 Hz~1 MHz (*9)	[mA]	1950	1800	1400	1000
Load regulation thermal drift		Less than 0.1 % of rated output current over			
Temperature coefficient	[ppm/°C]	100 ppm/°C from rated output current, following			
Temperature stability		0.05 % of rated Iout over 8 hrs interval following			
Warm-up drift		8~16 V model: Less than ±0.5 % rated output current			
<b>Constant Voltage Mode</b>					
Max. line regulation (0.01 % of rated Vo) (*3)	[mV]	0.8	1.0	1.6	2
Max. load regulation (0.015 % of rated Vo + 5 mV) (*4)	[mV]	6.2	6.5	7.4	8
Ripple and noise p-p 20 MHz (*5)	[mV]	75	75	75	75
Ripple RMS 5 Hz~1 MHz	[mV]	10	10	10	10
Remote sense compensation/wire	[V]	2	2	2	2
Temperature coefficient	[ppm/°C]	100 ppm/°C of rated output voltage, following			
Temperature stability		0.05 % of rated Vout over 8 hrs interval following			
Warm-up drift		Less than 0.05 % of rated output voltage + 2 mV			
Up-prog. response time, 0~Vo Rated (*6)	[ms]	30			
Down-prog. response time	Full-load (*6)	[ms]	15	50	
	No-load (*7)	[ms]	400	500	600
Transient response time	[ms]	Time for output voltage to recover within 0.5 % of its Less than 1 ms for models up to and including 100 V.			

\*1: Minimum voltage is guaranteed to maximum 0.2 % of rated output voltage.

\*2: Minimum current is guaranteed to maximum 0.4 % of rated output current.

\*3: 3-Phase 208 V models: 170~265 V AC, constant load.  
3-Phase 400 V models: 342~460 V AC, constant load.

\*4: From No-Load to Full-Load, constant input voltage. Maximum drop in Remote Sense.

\*5: For 8 V~300 V models: Measured with JEITA RC-9131A (1:1) probe.  
For 600 V model: Measured with 10:1 probe.

\*6: From 10 % to 90 % or 90 % to 10 % of Rated Output Voltage, with rated, resistive load.

\*7: From 90 % to 10 % of Rated Output Voltage.

30-170	40-125	60-85	80-65	100-50	150-34	200-25	300-17	400-13	500-10	600-8.5	
30	40	60	80	100	150	200	300	400	500	600	
170	125	85	65	50	34	25	17	13	10	8.5	
5100	5000	5100	5200	5000	5100	5000	5100	5200	500	5100	
30 minutes following load change.											
30 minutes warm-up.											
30 minutes warm-up. Constant line, load & temperature.											
over 30 minutes following power On. 20~600 V model: Less than $\pm 0.25\%$ of rated output current over 30 minutes following power On.											
3	4	6	8	10	15	20	30	40	50	60	
9.5	11	14	17.7	20	27.5	35	50	65	80	95	
75	75	75	100	100	120	220	300	350	400	500	
10	10	10	15	15	25	45	60	80	100	120	
5	5	5	5	5	5	5	5	5	5	5	
30 minutes warm-up.											
30 minutes warm-up. Constant line, load & temperature.											
over 30 minutes following power On.											
30		50					65	80	100		
80			100				135	170	200		
800	900	1000	1200	1500	2000	2500	3000				
rated output for a load change 10 – 90 % of rated output current. Output set-point: 10 – 100 %, local sense. 2 ms for models above 100 V.											

Sequel ►

\*8: For load voltage change, equal to the unit voltage rating, constant input voltage.

\*9: For 8 V~16 V models the ripple is measured from 2 V to rated output voltage and rated output current. For other models, the ripple is measured at 10~100 % of rated output voltage and rated output current.

Protective Functions	GEN	8-600	10-500	16-310	20-250
OCP		0~105 % Constant Current			
OCP Fold-back		Output shut-down when power supply change from			
OVP type		Inverter shut-down, manual reset by AC input recycle			
OVP trip point	[V]	0.5~10	0.5~12	1~19	1~24
Output under voltage limit		Preset by front panel or communication port. Prevents from adjusting Vout below limit.			
Over Temperature Protection		User-selectable, latched or non-latched			
Interface RS-232 & RS-485 or Optional GPIB / LAN Interface					
Model		8	10	16	20
Remote Current Programming (16 bit)					
Resolution (0.012 % of Io Rated)	[mA]	72	60	37.2	30
Accuracy (0.3 % of Io Rated + 0.1 % of Io Actual Output) (*10)	[mA]	2400	2000	1240	1000
Readback Current					
Resolution (0.012 % of Io Rated)	[mA]	72	60	37.2	30
Accuracy (0.4 % of Io Rated) (*10)	[mA]	2400	2000	1240	1000
Remote Voltage Programming (16 bit)					
Resolution (0.012 % of Vo Rated)	[mV]	0.96	1.2	1.92	2.4
Accuracy (0.1 % Vo Rated)	[mV]	8	10	16	20
Readback Voltage					
Resolution (0.012 % of Vo Rated)	[mV]	0.96	1.2	1.92	2.4
Accuracy (0.15 % Vo Rated)	[mV]	12	15	24	30
OVP/UVL Programming					
Resolution (0.1 % of Vo Rated)	[mV]	8	10	16	20
Accuracy (1 % of Vo Rated)	[mV]	80	100	160	200

Analog Programming and Monitoring	
Vout Voltage Programming	0~100 %, 0~5 V or 0~10 V, user-selectable. Accuracy and linearity: $\pm 0.5$ % of rated Vout.
Iout Voltage Programming (*10)	0~100 %, 0~5 V or 0~10 V, user-selectable. Accuracy and linearity: $\pm 1$ % of rated Iout.
Vout Resistor Programming	0~100 %, 0~5/10 k $\Omega$ full scale, user-selectable. Accuracy and linearity: $\pm 1$ % of rated Vout.
Iout Resistor Programming (*10)	0~100 %, 0~5/10 k $\Omega$ full scale, user-selectable. Accuracy and linearity: $\pm 1.5$ % of rated Iout.
On/Off control (rear panel)	By electrical. Voltage: 0~0.6 V/2~15 V, or dry contact, user-selectable logic
Output current monitor (*10)	0~5 V or 0~10 V, accuracy: $\pm 1$ %, user-selectable
Output voltage monitor	0~5 V or 0~10 V, accuracy: $\pm 1$ %, user-selectable
Power supply OK signal	TTL high (4~5 V) -OK, 0 V-Fail 500 $\Omega$ series resistance
CV/CC indicator	Open collector. CC mode: On, CV mode: Off. maximum voltage: 30 V, maximum sink current: 10 mA
Enable/Disable	Dry contact. Open: off, Short: on. Max. voltage at Enable/Disable in: 6 V
Local/Remote analog control	By electrical signal or Open/Short: 0~0.6 V or short: Remote, 2 ~15 V or open: Local
Local/Remote analog control indicator	Open collector, Local: Open, Remote: On. Maximum voltage: 30 V, maximum sink current: 10 mA

\*10: The Constant Current programming readback and monitoring accuracy does not include the warm-up and Load regulation thermal drift.

30-170	40-125	60-85	80-65	100-50	150-34	200-25	300-17	400-13	500-10	600-8.5
CV to CC. User-selectable.										
or by OUT button or by communication port command.										
2~36	2~44	5~66	5~88	5~110	5~165	5 ~ 220	5~330	5 ~ 440	5 ~ 550	5~660
30	40	60	80	100	150	200	300	400	500	600
20.4	15	10.2	7.8	6.0	4.08	3	2.04	1.56	1.2	1.02
680	500	340	260	200	136	100	68	52	40	34
20.4	15	10.2	7.8	6.0	4.08	3	2.04	1.56	1.2	1.02
680	500	340	260	200	136	100	68	52	40	34
3.6	4.8	7.2	9.6	12	18	24	36	48	60	72
30	40	60	80	100	150	200	300	400	500	600
3.6	4.8	7.2	9.6	12	18	36	36	48	60	72
45	60	90	120	150	225	450	600	800	1000	1200
30	40	60	80	100	150	200	300	400	500	600
300	400	600	800	1000	1500	2000	3000	4000	5000	6000

Front Panel	
Control functions	Vout/Iout manual adjust by separate encoders (coarse and fine adjustment selectable)
	OVP/UVL manual adjust by Volt. Adjust encoder
	AC on/off, Output on/off, re-start modes (auto, safe), Fold-back control (CV to CC), Go to local control
	Address selection by Voltage (or current) adjust encoder. Number of addresses: 31
	Re-start modes (automatic re-start, safe mode)
Display	Baud rate selection: 1200, 2400, 4800, 9600 and 19200
	Voltage: 4 digits, Accuracy: 0.5 % of rated output voltage $\pm 1$ count Current: 4 digits, Accuracy: 0.5 % of rated output current $\pm 1$ count
Indications	Voltage, Current, Alarm, Fine, Preview, Fold-back, Local, Output On, Front Panel Lock, CV/CC

Input Characteristics		GEN	8-600	10-500	16-310	20-250
Input voltage/freq. (*1)		[V AC]	3-Phase, 208 V models: 170~265 V AC, 47~63 Hz 3-Phase, 400 V models: 342~460 Vac, 47~63 Hz			
Maximum Input current at 100 % load	3-Phase, 208 V models	[A]	21	22	22	22
	3-Phase, 400 V models	[A]	10.5	11	11	12
Power Factor (Typ)						
Inrush peak current (*2)		[A]	3-Phase 208 V models: Less than 50 A 3-Phase 400 V models: Less than 20 A			
Efficiency at 208 V and 400 V (*3)		[%]	83	84	84	86
Hold-up time		[ms]	5 ms typical, Rated output power			

Power Supply Configuration	
Parallel operation	Up to 4 identical units in master/slave mode
Series operation	Up to 2 identical units with external diodes. 600 V max. to chassis ground
Environmental Conditions	
Operating temperature	0~50 °C, 100 % load
Storage temperature	-20~85 °C
Operating humidity	20~90 % RH (non-condensing)
Storage humidity	10~95 % RH (non-condensing)
Vibration	MIL-810F, method 514.5, The EUT is fixed to the vibrating surface
Shock	Less than 20 g, half sine, 11 ms unit is unpacked
Altitude	Operating: 10,000 ft (3,000 m), Derate output current by 2 % / 100 m above 2,000 m. Alternatively, derate maximum ambient temperature by 1 °C / 100 m above 2,000 m. Non-operating: 40,000 ft (12,000 m)
RoHS Compliance	Complies with the requirements of RoHS directive.
EMC	
Applicable Standards:	
ESD	IEC1000-4-2. Air-disch. -8 kV, contact disch. -4 kV
Fast transients	IEC1000-4-4. 2 kV
Surge immunity	IEC1000-4-5. 1 kV line to line, 2 kV line to ground
Conducted immunity	IEC1000-4-6, 3 V
Radiated immunity	IEC1000-4-3, 3 V/m
Magnetic field immunity	EN61000-4-8, 1A/m
Voltage dips	EN61000-4-11
Conducted emission	EN55022A, FCC part 15-A, VCCI-A
Radiated emission	EN55022A, FCC part 15-A, VCCI-A

\*1: For cases where conformance to various safety standards (UL, IEC, etc) is required, to be described as 190-240 V AC (50/60 Hz) for 3-Phase 208 V models, and 380~415 V AC (50/60 Hz) for 3-Phase 400 V models.

\*2: Not including EMI filter inrush current, less than 0.2 ms.

\*3: 3-Phase 208 V models: At 208 V AC input voltage, 3-Phase 400 V: At 380 V AC input voltage. With rated output power.

30-170	40-125	60-85	80-65	100-50	150-34	200-25	300-17	400-13	500-10	600-8.5
22	22	22	22	22	22	22	22	22	22	22
11	11	11	11	11	11	11	11	11	11	11
3-Phase models: 0.94@208/380/400 V AC, (at 100 % load)										
86	88	88	88	88	88	88	88	88	88	88

Safety	
Applicable standards	UL60950-1:1:2007 (Ed. 2), IEC 60950-1:2005 (Ed. 2), EN 60950-1:2006 (Ed. 2) + A11:2009
	40 <Vout ≤400 V: Output is hazardous, IEEE/Isolated analog are SELV
	400 <Vout ≤600 V: Output is hazardous, IEEE/Isolated analog are not SELV
Withstand voltage	Vout ≤40 V models: Input-Outputs (SELV): 4242 V DC 1 min, Input-Ground: 2828 V DC 1 min
	40 <Vout ≤100 V models: Input-Haz. Output: 2600 V DC 1 min, Input-SELV: 4242 V DC 1 min
	Hazardous Output-SELV: 1900 V DC 1 min, Hazardous Output-Ground: 1200 V DC 1 min, Input-Ground: 2828 V DC 1 min
	100 <Vout ≤600 V models: Input-Haz. Output: 4000 V DC 1 min, Input-SELV: 4242 V DC 1 min
	Hazardous Output-SELV: 3550 V DC 1 min, Hazardous Output-Ground: 2670 V DC 1 min, Input-Ground: 2828 V DC 1 min
Insulation resistance	More than 100 MΩ at 25 °C, 70 % RH
Mechanical Construction	
Cooling	Forced air flow: from front to rear. No ventilation holes at the top or bottom of the chassis; Variable fan speed.
Dimensions (WxHxD)	W: 423.0 mm, H: 88 mm, D: 442.5 mm (excluding connectors, encoders, handles, etc.)
Weight	16 kg
AC Input connector (with Protective Cover)	3-Phase, 208 V & 400 V models, Power Combicon PC 6-16/4-GF-10, 16 series, with Strain relief.
Output connectors	8 V to 100 V models: Bus-bars (hole Ø 10.5 mm). 150 V to 600 V models: wire clamp connector, Phoenix P/N: FRONT-4-H-7.62
Reliability specs	
Warranty	5 years

All specifications subject to change without notice.

# Outline drawings Genesys™ GEN 5 kW Units

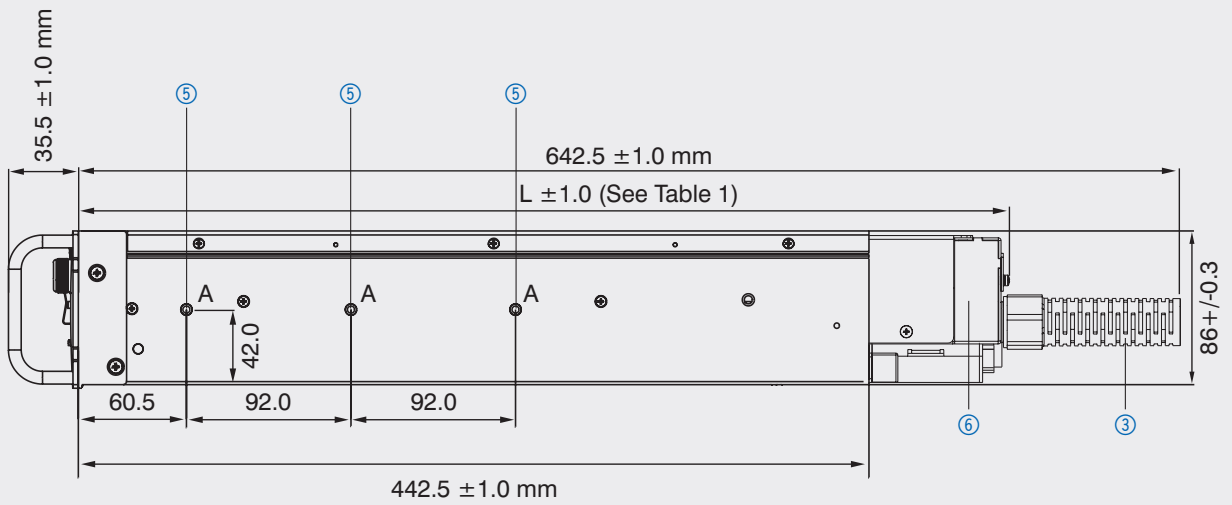
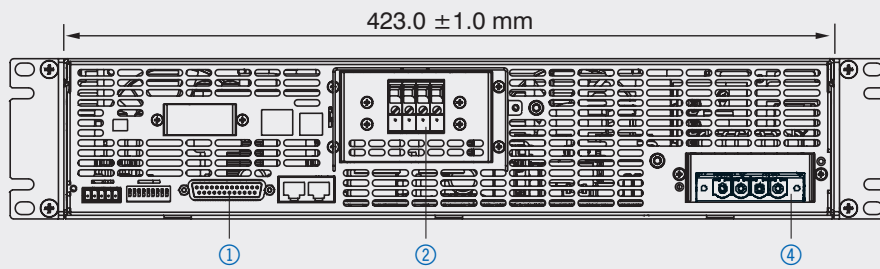
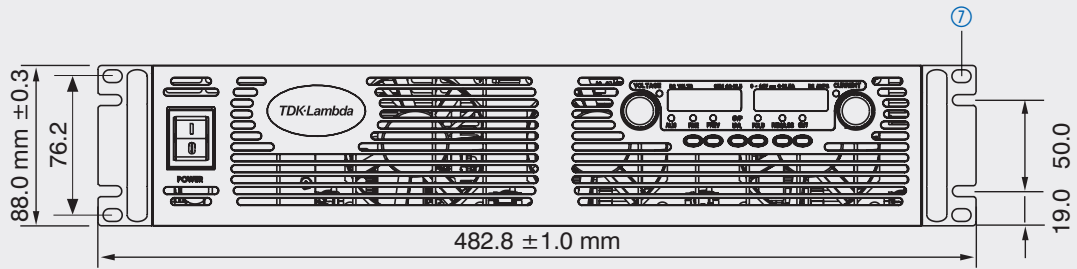

Dimension / Model	8 V – 10 V	16 V – 100 V
L	517.5 mm	497.5 mm

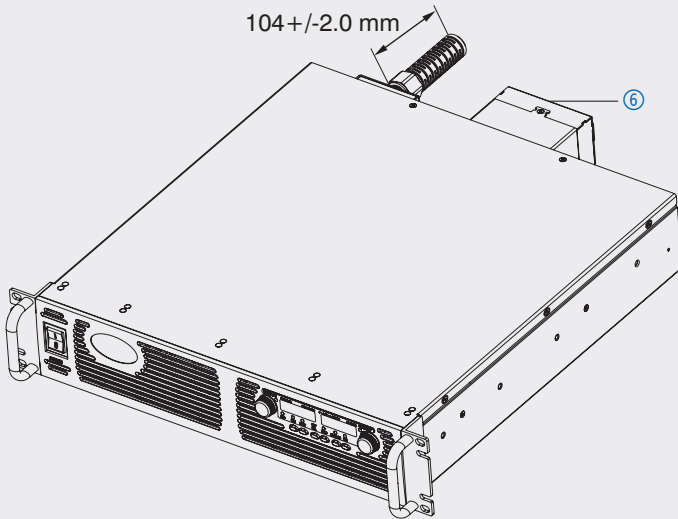

② **Bus-Bar Detail**  
16 V to 100 V Models

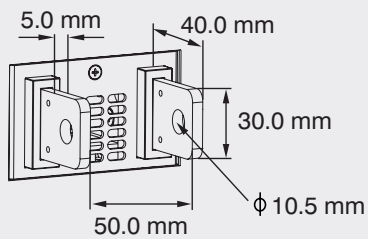

② **Bus-Bar Detail**  
8 V to 10 V Models

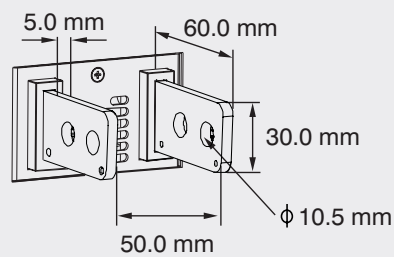

- ① Analog programming connector. Mating plug supplied with power supply.
- ② Bus-bars for 8 V to 100 V models. See detail. Wire clamp connector for 150 V to 600 V models (shown).
- ③ AC cable strain relief (supplied with power supply).
- ④ AC input connector (supplied with plug-in connector). Header P/N: PC6-16/4-GF-10,16 Phoenix Contact

- ⑤ Chassis slides mounting holes #10-32 marked "A". GENERAL DEVICES P/N: CC3001-00-S160 or equivalent.
- ⑥ Bus Bar enclosure for 60 V to 600 V.
- ⑦ Mounting holes for 19" rack. Use M6x16 screws to fix the unit to the rack.

NEW

# Genesys™ GEN 3.3/5 kW with Fast Speed (Option)



The new Genesys™ Fast Speed Models are especially designed for automotive test and similar ATE applications where fast output programming is needed.

## Features

- Up-and-down programming time 2 ms
- Low output capacitance
- Programming is 35 times faster than standard version
- Available for Genesys™ 3.3–5 kW

Model	Output Voltage [V DC]	Output Current [A]	Output Power [W]	Option Fast Speed [F]
GEN20-165	0~20	0~165	3300	•
GEN40-85	0~40	0~85	3400	•
GEN20-250	0~20	0~250	5000	•
GEN40-125	0~40	0~125	5000	•

## How to order

### Power Supply Identification with Fast Speed

GEN	20	-	250	-		-		-	F
Series name	Output voltage (0~20 V)	Output current (0~250 A)	Option: IEEE IS510 IS420 LAN	AC Input Options: 1P230 (Single Phase 230 V AC) 3P208 (Three Phase 208 V AC) 3P400 (Three Phase 400 V AC)	Fast Speed				

### Factory Option GEN 3.3/5 kW

RS-232/RS-485 Interface Built-in Standard	-
IEEE 488.2 (GPIB) Interface	IEEE
Voltage Programming Isolated Analog Interface	IS510
Current Programming Isolated Analog Interface	IS420
LAN Interface (Complies with <b>LXI</b> class C)	LAN

## Applications

- Developing and testing embedded electronics in situ
- Engine Control
- Powertrain Control  
(including hybrid drive technologies and electric drives)
- Vehicle Dynamics (e.g., ESP, damping control)
- Comfort Electronics
- Interior Systems
- Infotainment
- Noise Cancelation
- Diagnosis, etc.

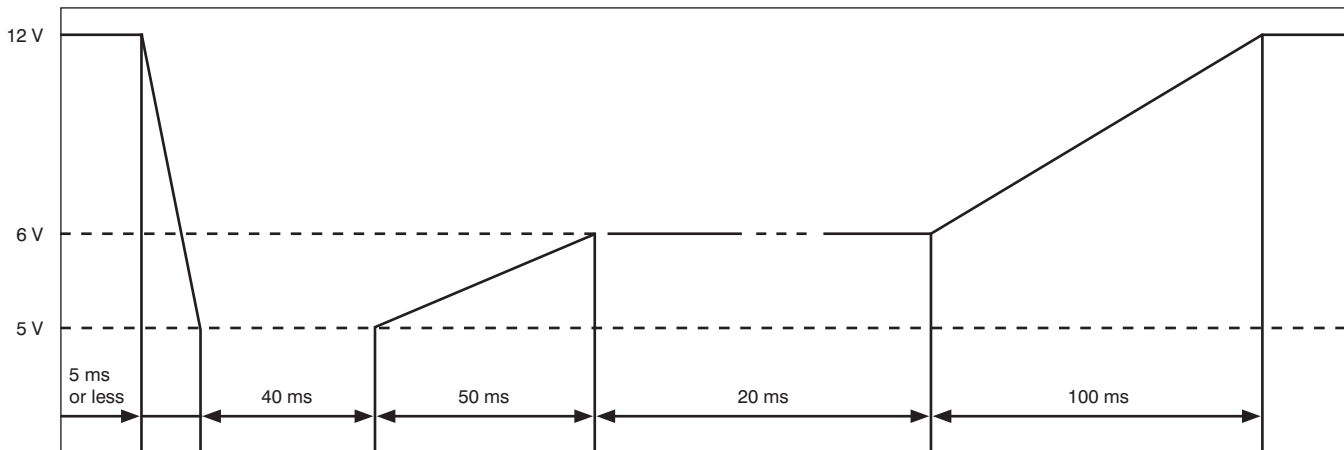

Simulation for Starter Motor Characteristics

## Specifications Genesys™ GEN 3.3/5 kW with Fast Speed (Option)

Specifications Fast Speed	GEN	20-165-F	40-85-F	20-250-F	40-125-F
<b>Fast Speed rating</b>					
Output Voltage	[V]	20	40	20	40
Output Current	[A]	165	85	250	125
Output Power	[W]	3300	3400	5000	5000
<b>Constant Voltage Mode</b>					
Ripple and noise p-p 20 MHz (*1) (*5)	[mV]	200	200	460	200
Ripple RMS 5 Hz~1 MHz	[mV]	50	50	60	40
Up-prog. response time, 0~Vo Rated (*2)	[ms]	2	4.2	1.8	1.8
Down-prog. response time, Full-load (*2)	[ms]	2	1.5	1.8	1
No-load (*3)	[ms]	20	40	15	40
<b>Constant Current Mode</b>					
Ripple RMS 5 Hz~1 MHz (*4)	[mA]	1000	800	1000	1000
<b>Output Capacitance (typ.)</b>	[μF]	550	626	740	476

\*1: For 8 V~300 V models: Measured with JEITA RC-9131A (1:1) probe.

\*2: From 10 % to 90 % or 90 % to 10 % of Rated Output Voltage, with rated, resistive load (Kind of output load effected the output rise and fall time)

\*3: From 90 % to 10 % of Rated Output Voltage.

\*4: For 8 V~16 V models the ripple is measured from 2 V to rated output voltage and rated output current. For other models, the ripple is measured at 10~100 % of rated output voltage and rated output current. In CC-Mode used low inductive cabling

\*5: Tambient: = 25~50°C

# Genesys™ GEN 10/15 kW in 3U 19" rack

Model	Output Voltage [V DC]	Output Current [A]	Output Power [kW]
GEN7.5-1000	0~7.5	0~1000	7.5
GEN10-1000	0~10	0~1000	10
GEN12.5-800	0~12.5	0~800	10
GEN20-500	0~20	0~500	10
GEN25-400	0~25	0~400	10
GEN30-333	0~30	0~333	10
GEN40-250	0~40	0~250	10
GEN50-200	0~50	0~200	10
GEN60-167		0~167	10
GEN60-250	0~60	0~250	15
GEN80-125		0~125	10
GEN80-187.5	0~80	0~187.5	15
GEN100-100		0~100	10
GEN100-150	0~100	0~150	15
GEN125-80		0~80	10
GEN125-120	0~125	0~120	15
GEN150-66		0~66	10
GEN150-100	0~150	0~100	15
GEN200-50		0~50	10
GEN200-75	0~200	0~75	15
GEN250-40		0~40	10
GEN250-60	0~250	0~60	15
GEN300-33		0~33	10
GEN300-50	0~300	0~50	15
GEN400-25		0~25	10
GEN400-37.5	0~400	0~37.5	15
GEN500-20		0~20	10
GEN500-30	0~500	0~30	15
GEN600-17		0~17	10
GEN600-25	0~600	0~25	15

## How to order

### Power Supply Identification GEN 10/15 kW 3U

GEN	10	-	1000	-	MD	-	
Series name	Output voltage (0~10 V)		Output current (0~1000 A)		Option: IEMD IS510 IS420 LAN		AC Input Options: 3P208 (Three Phase 208 V AC) 3P400 (Three Phase 400 V AC) 3P480 (Three Phase 480 V AC)

### Factory Option GEN 10/15 kW

### P/N:

RS-232/RS-485 Interface Built-in Standard	-
GPIO (Multi Drop Master) Interface	IEMD
Voltage Programming Isolated Analog Interface	IS510
Current Programming Isolated Analog Interface	IS420
LAN Interface (Complies with <b>LXI</b> class C)	LAN

## Front panel description GEN 10/15 kW in 3U 19" rack

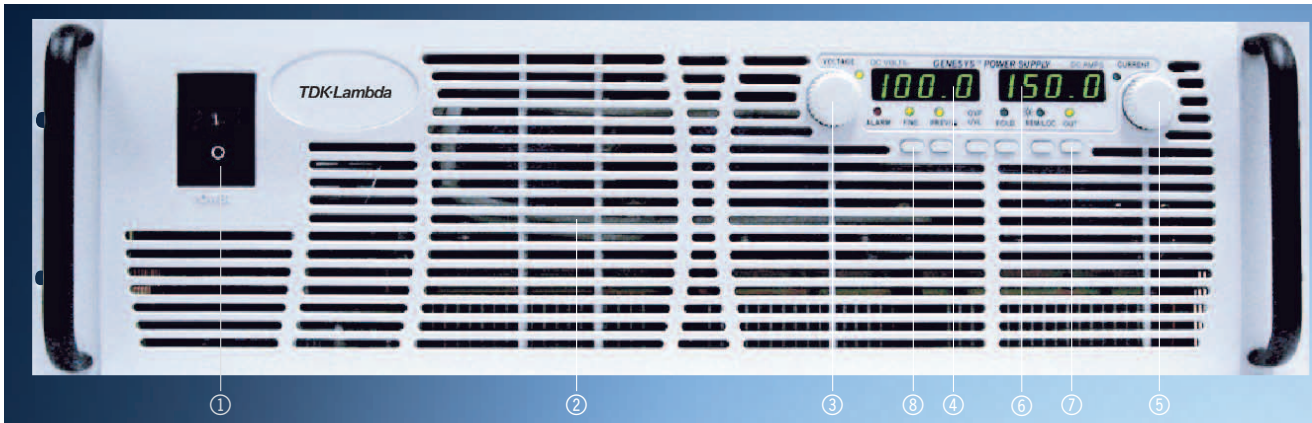

- ① ON/OFF Switch
- ② Air Intake allows zero stacking for maximum system flexibility and power density.
- ③ Reliable encoder controls Output Voltage, Address, OVP and UVL settings.
- ④ Volt Display shows Output Voltage and directly displays OVP, UVL and Address settings.
- ⑤ Reliable encoder controls Output Current, sets Baud rate and Advanced Parallel Mode.
- ⑥ Current Display shows Output Current and displays Baud rate. Displays total current in Parallel Master/Slave Mode.
- ⑦ Function/Status LEDs:
  - Alarm
  - Fine Control
  - Preview Settings
  - Fold-back Mode
  - Remote Mode
  - Output On
- ⑧ Push-buttons allow flexible user configuration:
  - Coarse and Fine adjustment of Output Voltage/Current and Advanced Parallel Master or Slave select.
  - Preview settings and set Voltage/Current with Output OFF, Front Panel Lock
  - Parallel Master/Slave
  - Set OVP and UVL Limits
  - Set Current Fold-back Protection
  - Local/Remote Mode and select Address and Baud rate
  - Output ON/OFF and Auto-Re-Start/Safe-Start Mode

## Rear panel description GEN 10/15 kW in 3U 19" rack

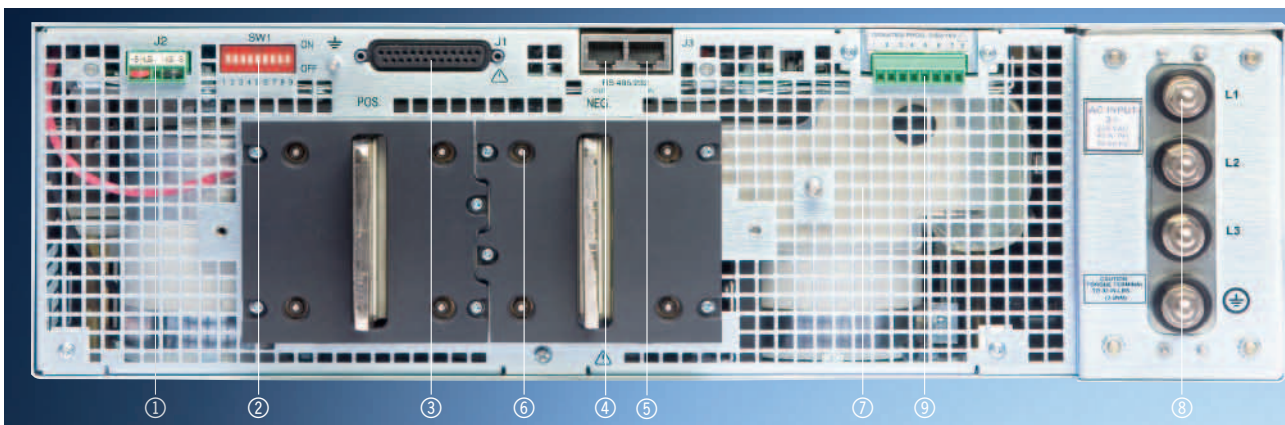

- ① Remote/Local Output Voltage Sense Connections.
- ② DIP Switches select 0–5 V or 0–10 V Programming and other functions.
- ③ DB25 (Female) connector allows (Non-isolated) Analog Program and Monitor and other functions.
- ④ RS-485 OUT to other Genesys™ Power Supplies.
- ⑤ RS-232/RS-485 IN Remote Serial Programming.
- ⑥ Output Connections:
  - Rugged 2 hole busbars (shown) for up to 30 V output
  - Single hole busbars 40 V to 300 V output
  - Threaded stud terminals above 300 V output
- ⑦ Exit air assures reliable operation when zero stacked.
- ⑧ AC Input:
  - Input Terminals L1, L2, L3, Ground, threaded studs
- ⑨ Optional Interfaces Position for IEEE 488.2 (GPIB), Isolated Analog Interface (shown) or LAN interface.

# Specifications Genesys™ GEN 10/15 kW

Model (10 kW)	GEN	7.5-1000	10-1000	12.5-800	20-500	25-400	30-333	40-250
Rated output voltage	[V]	7.5	10	12.5	20	25	30	40
Rated output current	[A]	1000	1000	800	500	400	333	250
Rated output power	[kW]	7.5	10.0	10.0	10.0	10.0	10.0	10.0
Efficiency (min) at low line, 100 % Rated Load	[%]	77	83					
Model (15 kW)	GEN							
Rated output voltage	[V]							
Rated output current	[A]							
Rated output power	[kW]							
Efficiency (min) at low line, 100 % Rated Load	[%]							
Contact factory for other models								
Constant Current Mode (10 kW)								
Max. line regulation (0.1 % Io Max. ≥333 A; 0.05 % <333 A)	[mA]	1000	1000	800	500	400	333	125
Max. load regulation (0.1 % Io Max. ≥333 A; 0.075 % <333 A)	[mA]	1000	1000	800	500	400	333	188
Ripple RMS 5 Hz~1 MHz c.c	[mA]	5100	5100	2600	2600	1700	1700	100
Constant Current Mode (15 kW)								
Max. line regulation (0.1 % Io Max. ≥333 A; 0.05 % <333 A)	[mA]							
Max. load regulation (0.1 % Io Max. ≥333 A; 0.075 % <333 A)	[mA]							
Ripple RMS 5 Hz~1 MHz c.c	[mA]							
Constant Current Mode (10/15 kW)								
Temp. drift c.c		±0.05 % of Io Rated Over 8 hours, after 30 minute warm up, constant Line, Load &						
Temp. coefficient c.c	[ppm/°C]	300 (0.03 % Full Scale) / °C						
Constant Voltage Mode (10/15 kW)								
Max. line regulation (0.1% Vo Max. ≤30 V; 0.01 % >30 V)	[mV]	7.5	10	12.5	20	25	30	4
Max. load regulation (0.1 % Vo Max. ≤30 V; 0.02 % >30 V)	[mV]	7.5	10	12.5	20	25	30	8
Ripple RMS 5 Hz~1 MHz c.v (*1)	[mV]	20	20	20	20	20	20	20
Output noise p-p (20 MHz) c.v (*1)	[mV]	60	60	60	60	60	60	60
Remote sense compensation/wire	[V]	1	1	1	1	1	1.5	2
Temp. drift c.v		±0.05 % of Vo Rated Over 8 hours, after 30 minute warm up, constant Line, Load &						
Temp. coefficient c.v	[ppm/°C]	200 (0.02 % Vo Rated) / °C						
Up-prog. response time, 0~Vo max, full-load	[ms]							
Up-prog. response time, 0~Vo max, no load	[ms]							
Transient response time (cv mode) (*2)	[ms]	Less than 3						

\*1: Ripple and Noise at Full Rated Voltage & Load at 25 °C, Nominal Line.  
Per EIJ R9002A

\*2: Time for the rated output voltage to recover within 2 %  
for a load change of 50~100 % or 100~50 % of rated output.

50-200	60-167	80-125	100-100	125-80	150-66	200-50	250-40	300-33	400-25	500-20	600-17
50	60	80	100	125	150	200	250	300	400	500	600
200	167	125	100	80	66	50	40	33	25	20	17
10.0	10.0	10.0	10.0	10.0	9.9	10.0	10.0	9.9	10.0	10.0	10.2
83											
	60-250	80-187.5	100-150	125-120	150-100	200-75	250-60	300-50	400-37.5	500-30	600-25
	60	80	100	125	150	200	250	300	400	500	600
	250	187.5	150	120	100	75	60	50	37.5	30	25
	15.0	15.0	15.0	15.0	15.0	15.0	15.0	15.0	15.0	15.0	15.0
88											

100	83.5	62.5	50	40	33	25	20	17	13	10	9
150	125	94	75	60	50	38	30	25	19	15	13
80	67	50	40	32	26	20	16	13	10	8	7
	125	94	75	60	50	38	30	25	19	15	13
	188	141	113	90	75	56	45	38	28	23	19
	100	100	100	50	50	20	20	20	10	10	10

Temperature  
300 (0.03 % Full Scale) / °C

5	6	8	10	12.5	15	20	25	30	40	50	60
10	12	16	20	25	30	40	50	60	80	100	120
20	20	25	25	25	25	35	35	60	60	60	60
75	75	100	100	125	150	175	200	200	300	350	350
3	3	4	5	5	5	5	5	5	5	5	5

Temperature  
100  
50

Sequel ▶

Protective Functions		
OCP	[%]	0~100
OCP type		Constant current
Fold-back protection		Output shut-down, manual reset by front panel OUT button
Fold-back response time	[s]	Less than 1
OVP type		Inverter shut-down, manual reset by On/Off recycle or by OUT button
OVP programming accuracy	[%]	5 % Full Scale
OVP trip point	[V]	0.05 to (1.02 – 1.05) x Rated Output Voltage
OVP response time	[ms]	Less than 10 ms for Output to begin to drop
Max. OVP reset time	[s]	7 from Turn On
Over temperature protection		Shut down if internal temperature exceeds safe operating levels (Latched in Safe Mode / Unlatched in Auto Mode)
Phase Loss Protection		Yes
Remote Analog Controls & Signals		
Vout voltage programming	0~100 %, 0~5 V or 0~10 V, user selectable. Accuracy & Linearity $\pm 1$ % of Rated Vo.	
Lout voltage programming	0~100 %, 0~5 V or 0~10 V, user selectable. Accuracy & Linearity $\pm 1$ % of Rated Io.	
Vout resistor programming	0~100 %, 0~5/10 k $\Omega$ full scale, user selectable. Accuracy & Linearity $\pm 1$ % of Rated Vo.	
Lout resistor programming	0~100 %, 0~5/10 k $\Omega$ full scale, user selectable. Accuracy & Linearity $\pm 1$ % of Rated Io.	
On/Off control (rear panel)	By Voltage: 0.6 V = Disable, 2 – 15 V = enable (default) or dry contact, user selectable logic	
Output current monitor	0~5 V or 0~10 V, accuracy: $\pm 1$ %, user selectable	
Output voltage monitor	0~5 V or 0~10 V, accuracy: $\pm 1$ %, user selectable	
Power supply OK signal	Yes. TTL high-OK, 0 V (500 $\Omega$ impedance)-Fail	
CV/CC signal	CV: TTL high (4~5 V) source: 10 mA, CC: TTL low (0~0.4 V): sink current 10 mA	
Enable/Disable	Dry contact. Open: Off, Short: On. Max. voltage at Enable / Disable Contacts 6 V	
Remote/Local selection	Selects Remote or Local operation by Voltage: 0~0.6 V / 2~15 V, <0.6 V = Local 2~15 V = Remote	
Remote/Local signal	Signals operating mode in use	
Front Panel		
Control functions	Vout/lout manual adjust by separate encoders, Fine and Coarse selectable.	
	OVP/UVL manual adjust by Voltage Adjust encoder, Front Panel Lock/Unlock	
	Address selection by Voltage Adjust encoder. No of addresses: 31	
	AC On/Off, Output On/Off, Restart Modes (Auto/Safe), Fold-back Control (CV to CC), Go to Local	
	RS232/485 and IEEE488.2 selection by IEEE enable switch and DIP switch	
	Baud rate selection by Current adjust encoder (1200 ~ 19.200)	
	Parallel Master Slave: Hx, where x = Slaves 0 up to four	
Display	Vout: 4 digits, Accuracy: 0.5 % of Io rated $\pm 1$ count	
	Iout: 4 digits, Accuracy: 0.5 % of Io rated $\pm 1$ count	
	Voltmeter is user selectable to read either local voltage (at power supply) or remote voltage (at the load)	
Indications	ADDR., OVP/UVL, V/A, FOLD, REM./LOCAL, OUT ON/OFF, LFP/UFP, CC/CV: GREEN LED's. ALARM (OVP, OTP, FOLD, AC FAIL): RED LED	

Digital Programming & Readback	
Vout programming accuracy	±0.5 % of rated output voltage
Lout programming accuracy	±0.5 % of rated output current for units with $I_o < 187.5$ ±0.7 % of rated output current for $I_o \geq 187.5$
Vout programming resolution	0.02 % of full scale
Lout programming resolution	0.04 % of full scale
Vout readback accuracy	0.1 % + 0.2 % of rated output voltage
Lout readback accuracy	0.1 % + 0.4 % of rated output current
Vout readback resolution	0.02 % of full scale
Lout readback resolution	0.02 % of full scale
OV Response time	20 ms maximum between output V exceeding IEEE Limit and supply inhibit turning on
Other Functions	Set Over-Voltage Limit, Set Local/Remote
Input Characteristics	
Input voltage / freq. (range)	208 V AC (180~253); 400 V AC (360/440); 480 V AC (432~528), all 47 – 63 Hz
No. of phases	3 Phases (Wye or Delta) 4 wire total (3 Phase and 1 protective earth ground)
Dropout voltage	180 / 360 / 432 V
Input current 180 / 360 / 432 V AC	10 kW – 45 / 23 / 20 A. 15 kW – 64 / 32 / 27 A. All at full rated output power.
Inrush current	No inrush current greater than the steady state input current. full rated Input current.
Power Factor	0.88 Passive
Leakage current	3.5 mA (EN60950) max.
Input Protection	208 V AC Circuit Breaker; 400 V AC, 480 V AC – Line Fuse
Input Overvoltage Protection	Unit shall not be damaged by line overvoltage with max. duration of 100 $\mu$ s. Up to 120 % of nominal AC input voltage.
Phase Imbalance	≤ 5 % on Three Phase Input
Power Supply Configuration	
Parallel Operation	Up to four (4) identical units may be connected in Master/Slave Mode with 'Single' wire connection. In Advanced parallel feature, the current of Master unit, multiplied by number of units connected in parallel, is made available on digital interface and displayed on front panel of Master unit. Remote analog current monitor of the Master is scaled to output current of the Master unit (only).
Series Operation	Possible (with external diodes), up to 2 identical units with total output not to exceed ±600 V from chassis ground.
Environmental Conditions	
Operating temperature	0~50 °C, 100 % load
Storage temperature	-20~70 °C
Operating humidity	20~80 % RH (non-condensing)
Storage humidity	10~90 % RH (non-condensing)
Vibration & Shock (208 / 400 V AC)	ASTM D4169, Standard Practice for Performance Testing, of Shipping Container-sand Systems. Shipping Unit: Single Package. Assurance Level: Level II. Acceptance Criteria: Criterion 1 – No product damage. Criterion 2 – Packaging is intact. Distribution Cycle: 12 – Air (intercity) and motor freight (local), unitized is used
Altitude	Operating: 50 °C up to 7,500 ft (2,500 m), 45 °C from 7,501 to 10,000 ft (2,501 – 3,000 m) Non operating 40,000 ft (12,000 m)
Audible Noise	65 dBA at full load, measured 1 m from front panel

EMC	
<b>208 V input models</b>	<b>CE Mark</b>
ESD	EN61000-4-2 (IEC 801-2) air-disch. ±8 kV, contact disch. ±4 kV
Fast transients	EN61000-4-4 (IEC 1000-4-3)
Surge immunity	EN61000-4-5 (IEC 1000-4-5)
Conducted immunity	EN61000-4-6 (IEC 1000-4-6)
Radiated immunity	EN61000-4-3 (IEC 1000-4-3)
Power frequency magnetic field	EN61000-4-8
Conducted emission	EN55011A, FCC part 15J-A
Radiated emission	EN55011A, FCC part 15J-A
<b>400 V input models</b>	<b>CE Mark</b>
ESD	EN61000-4-2 (IEC 801-2) Air-disch. ±8 kV, contact disch. ±4 kV
Fast transients	EN61000-4-4 (IEC 1000-4-3)
Surge immunity	EN61000-4-5 (IEC 1000-4-5)
Conducted immunity	EN61000-4-6 (IEC 1000-4-6)
Radiated immunity	EN61000-4-3 (IEC 1000-4-3)
Power frequency magnetic field	EN61000-4-8
Voltage dips, short interruptions and voltage variations immunity tests (400 V AC only)	IEC 61000-4-11
Conducted emission	EN55011A, FCC part 15J-A
Radiated emission	EN55011A, FCC part 15J-A
Safety	
Applicable standards	UL 60950-1:2007 (Ed.2), IEC 60950-1:2005 (ED. 2), EN60950-1:2006 (Ed. 2) Vout ≤ 40 V: Output is SELV, IEEE/Isolated Analog/LAN/USB are SELV 40 < Vout ≤ 400 V: Output hazardous; IEEE/Isolated Analog/LAN/USB are SELV 400 < Vout ≤ 600 V: Output hazardous; IEEE/Isolated Analog/LAN/USB are SELV, CE Mark 208 & 400 V AC Inputs only (CB Scheme)
Insulation resistance	100 MΩ at 500 V DC
Withstand Voltage	Vout ≤ 60 V models: Input-Ground: 2818 V DC 1 min., Input-Outputs (SELV): 4242 V DC 1 min. Output-Ground: 1000 V DC 1 min. 60 < Vout ≤ 300 V models: Input-Ground: 2828 V DC 1 min., Input-Haz. Output: 3535 V DC 1 min. Input-SELV: 2828 V DC 1 min. Hazardous Output-SELV: 2121 V DC 1 min. Hazardous Output-Ground: 2121 V DC 1 min. 300 < Vout ≤ 600 V models: Input-Ground: 2828 V DC 1 min., Input-Haz. Output: 3535 V DC 1 min. Input-SELV: 2828 V DC 1 min. Hazardous Output-SELV: 2688 V DC 1 min. Hazardous Output-Ground: 2688 V DC 1 min.
Mechanical Construction	
Cooling	Fan driven, airflow from front to rear. Supplemental vents on side that shall not be blocked. EIA rack mounting, stackable. "Zero stackable" top and bottom. Slides or suitable rear support required.
Dimensions (WxHxD)	W: 19" (429 mm), H: 3 U (133 mm), D: 564 mm without connectors handles.
Weight	43 kg / 97 lbs
Types of connectors	Input: Threaded studs M 6x1" (3 + GND) and terminal cover. Strain relief optional. Output: Up to and including 300 V models: bus-bars. Greater than 300 V models: threaded stud terminals. Analog programming: DB25, plastic connector, AMP, 747461-5, female on power supply, male on mating connector 747321. Standard 25 pin D connector.
Mounting method	Standard 19" rack Mount, provision for standard slides. Side/Rear Support is required; do not mount by F/P only.
Output ground connection	M5 Stud
Reliability specs	
Warranty	5 years

# Outline drawings Genesys™ GEN 10/15 kW Units

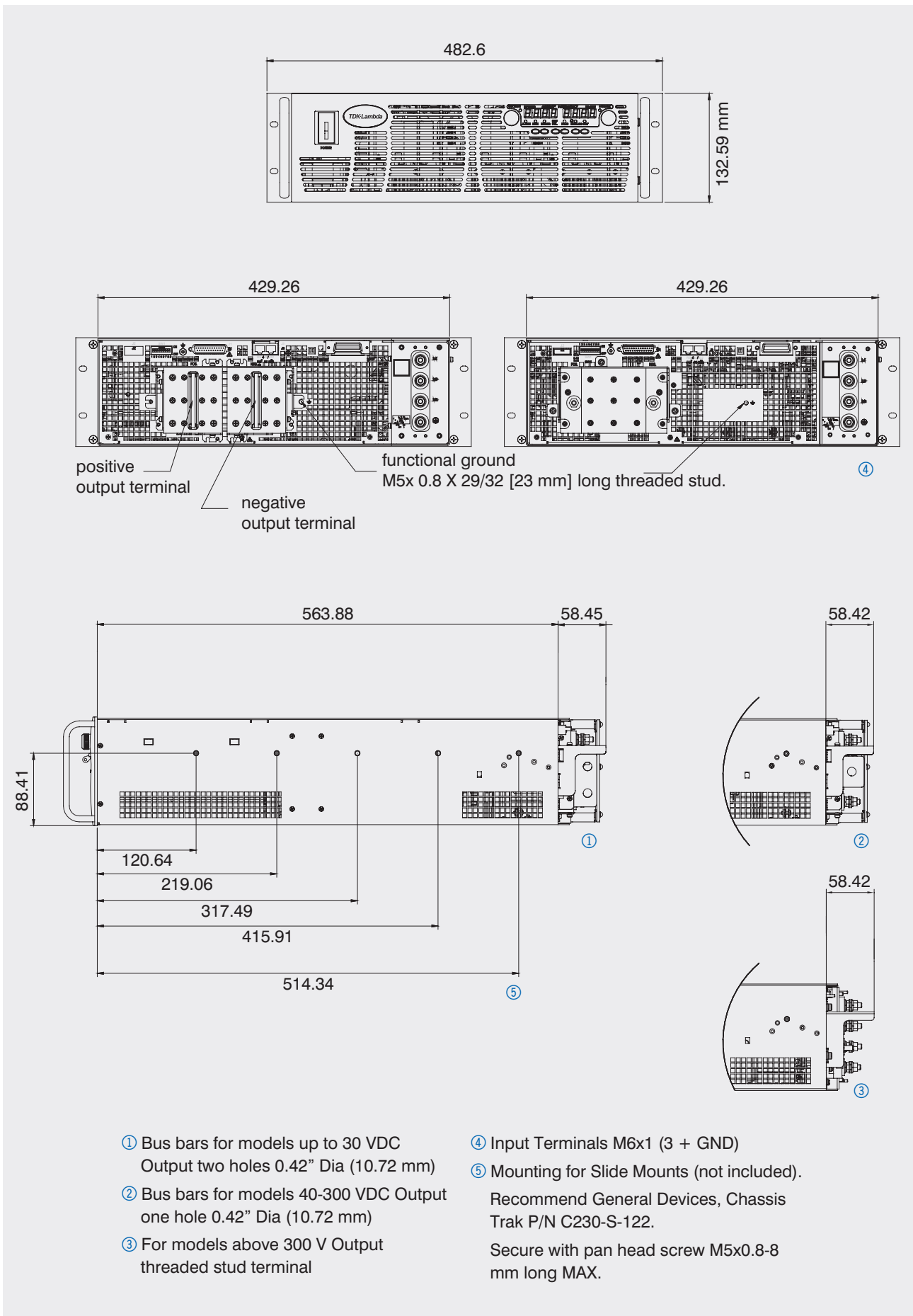

# Genesys™ Standard Configurations

## Rack Power Supply

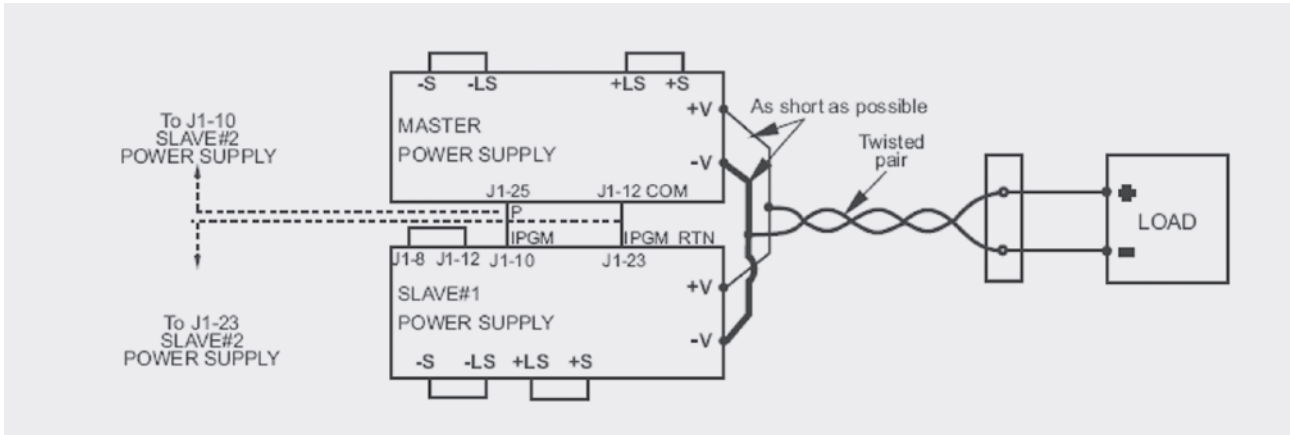

### Parallel operation – Master/Slave

Active current sharing allows up to four identical units to be connected in an auto-parallel configuration for four times the output power.

In Advanced Parallel Master/Slave Mode, total current is programmed and reported by the Master, up to four supplies act as one. See also Genesys™ Accessories Parallel Kit page 95.

### Series operation

Up to two units may be connected in series to increase the output voltage or to provide bipolar output. (Max 600 V to Chassis Ground).

## Remote Programming via RS-232 and RS-485 Interface

Standard Serial Interface allows daisy-chain control of up to 31 power supplies on the same communication bus with built-in RS-232 & RS-485 Interface.

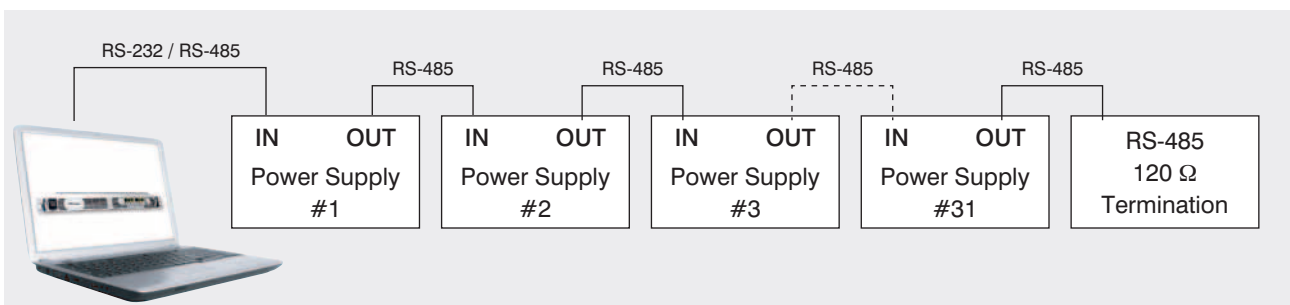

Multi power supplies RS-232 / RS-485 connection

# Genesys™ Interface Options

## Programming options Factory installed

### Isolated Analog Programming

- Four channels to Program and Monitor Voltage and Current.
- Isolation allows operation with floating references in harsh electrical environments.
- Choose between programming with Voltage or Current.
- Connection via removable terminal block: Phoenix MC1,5/8-ST-3.81.

- Voltage Programming, user-selectable 0 – 5 V or 0 – 10 V signal.
  - Power supply Voltage and Current Programming Accuracy  $\pm 1\%$
  - Power supply Voltage and Current Monitoring Accuracy  $\pm 1.5\%$

**P/N: IS510**

- Current Programming with 4 – 20 mA signal.
  - Power supply Voltage and Current Programming Accuracy  $\pm 1\%$
  - Power supply Voltage and Current Monitoring Accuracy  $\pm 1.5\%$

**P/N: IS420**

### Digital Programming via IEEE Interface

**P/N: IEEE**

- IEEE 488.2 SCPI compliant
- Program Voltage
- Program Current
- Measure Voltage
- Measure Current
- Over Voltage setting and shutdown
- Current Fold-back shutdown
- Error and Status Messages
- Multi-Drop
  - Allows IEEE Master to control up to 31 slaves over RS-485 daisy-chain
  - Only the Master needs be equipped with IEEE Interface

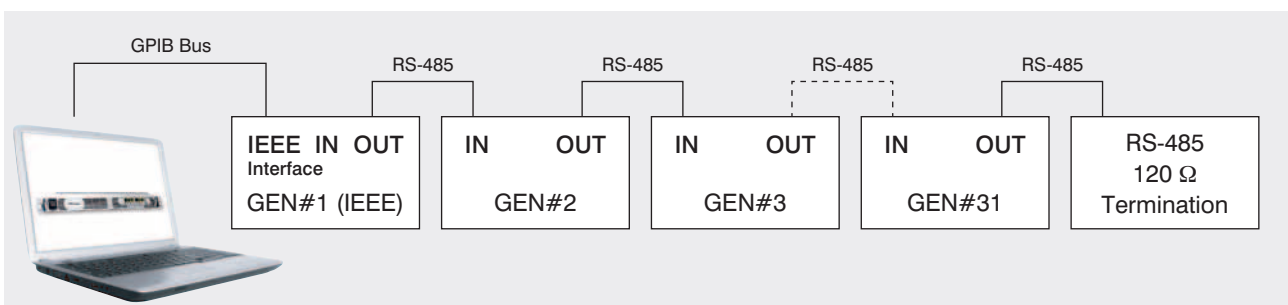

Multi-drop power supplies configuration

# Genesys™ LAN 2.0 Interface

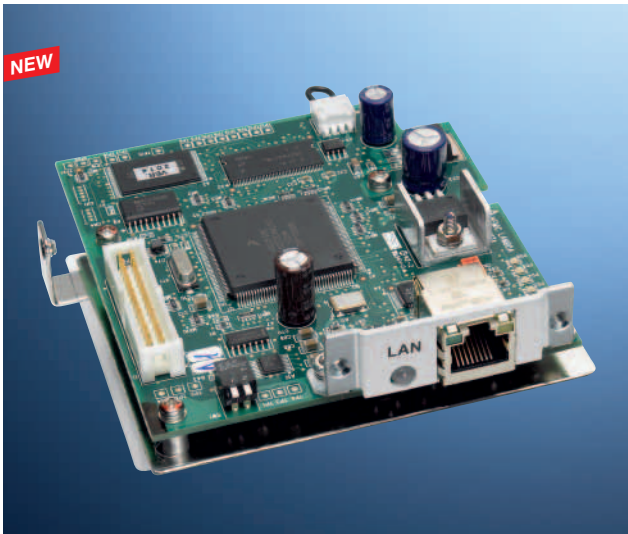

The optional LAN Interface for Genesys™ power supplies has been upgraded to provide many new features including functionality for users outside of Test and Measurement. We now offer TCP and UDP networking protocols for alternative operating systems, programming languages and controllers. The option maintains **LXI-C** Certification.

P/N: LAN

- **Adds TCP and UDP Sockets**

LAN 2.0 expands connectivity for many customers beyond standard test software, operating systems and controllers.

- **Change IP Address using Front Panel Current Encoder**

The current encoder will change the IP address. Locking in a new address requires a confirmation button press, to prevent accidental changes. Address conflicts (duplicate IP) are prevented.

- **The LAN remains LXI-C Certified**

- **Adds Multiple Controllers**

The new LAN allows two or more controller devices to “talk” to the power supply at the same time. The controllers may use any mix of TCP or UDP protocols.

- **Duplicate IP Recovery**

If the user accidentally sets a duplicate IP address, which is already used by another device, LAN 2.0 will reconnect to the last working address instead of disconnecting from the network. A Front Panel and/or web page alert is posted to the user.

- **Higher Capacity Input Buffer**

The number of commands that may be sent at once has been increased from four to twenty commands.

- **Adds Network Security Setting**

A new security button, on the web page, can be set for “allow only one controller using a secure protocol” or “allow everybody at the same time” to talk to the power supply. (Note: UDP is not a secure protocol, TCP and VISA are secure).

- **Improves Message Terminators**

The traditional terminator for messages is the line-feed character. The new LAN 2.0 sockets will accept and return the line-feed.

- **Improved LAN User Manual**

New manual includes specification on command speed and has an easier to use layout.

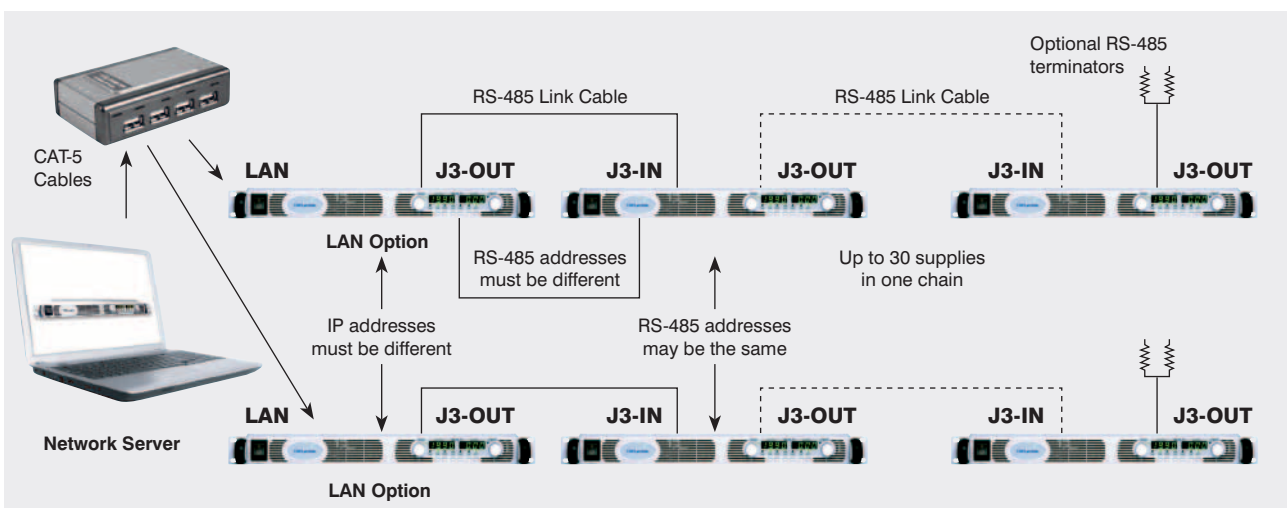

Configuring a Multi-drop System of supplies

# Genesys™ Software and Drivers

The Genesys™ family of programmable power supplies offer several interfaces such as RS-232/RS-485, IEEE 488.2 SCPI or LAN **IVI**, to control from a computer-system. With graphic programming languages such as LabView™ the Genesys™ can easily be integrated into complex test applications and production lines.

The TDK-Lambda website offers free download of several drivers and runtime engines to control Genesys™. In the product section for programmable power supplies there is a link to the software download for each series.

After registration on the following website is given access to drivers and runtime engines for LabView™ and LabWindows™. Now available are the IVI-Com and IVI-C drivers for Serial, IEEE and LAN.

[www.us.tdk-lambda.com/hp/register.htm](http://www.us.tdk-lambda.com/hp/register.htm)

The driver download is updated continuously. For special requirements, please contact your local Sales Office.

## Genesys™ Control Software 3.3.1

This is an easy way to use runtime engine for Windows to control up to two Genesys™ units via RS-232 interface. The software can easily be downloaded as a ZIP-file including documentation.

### General Information

- Genesys™ Control is an application to control up to two Genesys™ devices via the serial line.
- Genesys™ Control supports all Genesys™ types (GEN and GENH) and all available firmware versions.
- Genesys™ Control replicates the power supply front panel features on your PC.

### Computer Requirements

- A Windows PC with Win 95, 98, 98SE, ME, 2000 or XP, >200 MHz CPU, at least 32 MB RAM and 1 MB of HD space.

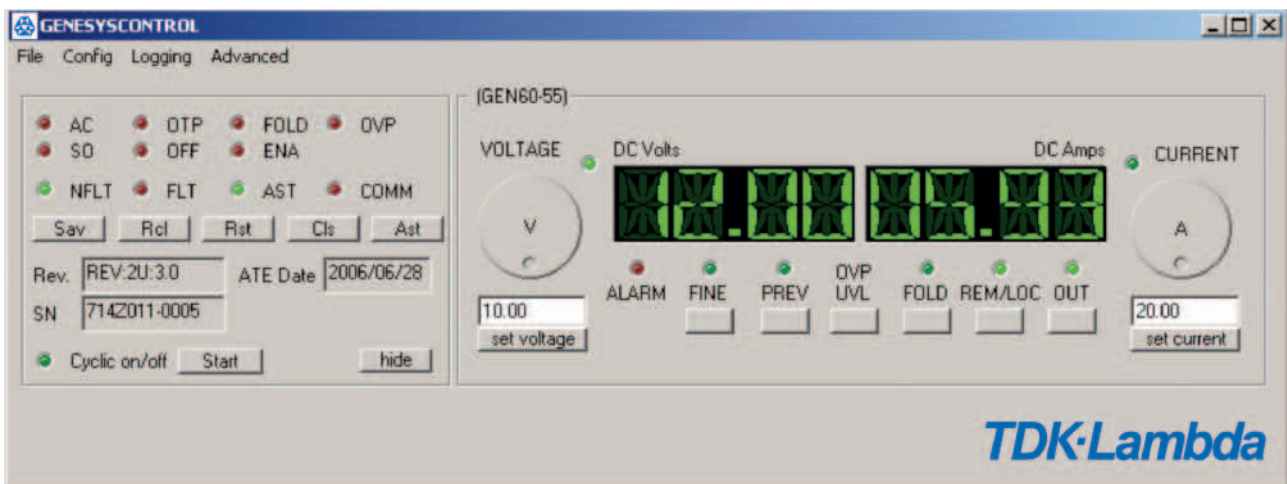

# Genesys™ Accessories

## Communication Cable

RS-232/RS-485 Cable is used to connect the power supply to the PC Controller

Mode	RS-485	RS-232	RS-232
PC Connector	DB-9F	DB-9F	DB-25F
Communication Cable	Shield Ground L=2 m	Shield Ground L=2 m	Shield Ground L=2 m
Power Supply Connector	EIA/TIA-568A (RJ-45)	EIA/TIA-568A (RJ-45)	EIA/TIA-568A (RJ-45)
Part Number	P/N: GEN/485-9	P/N: GEN/232-9	P/N: GEN/232-25

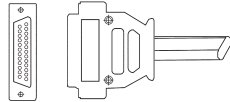

DB-25 (female connector)

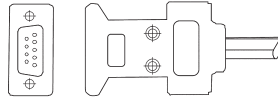

DB-9 (female connector)

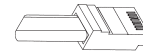

EIA/TIA (RJ-45)

## Serial link cable (Included with power supplies)

Mode	Power Supply Connector	Communication Cable	P/N
RS-485	EIA/TIA-568A (RJ-45)	Shield Ground L=50 cm	GEN/RJ45

## USB Interface Solutions for Genesys™



Digitus part number:

DA-70156

### Features

- Easy connection of serial devices through an USB port
- Supports RS232 serial interface
- Compliant with USB 2.0 standards
- Supports Windows 7, Vista, XP, Mac OS X and Linux

Driver:

<http://www.digitus.info/en/products/accessories/adaptor-and-converter/digitus-usb-to-serial-adaptor-usb-20/>

Small quantities of the Digitus device are available for purchase from TDK-Lambda

The most cost effective way to connect a Genesys or Z<sup>+</sup> to a computer via its USB interface is to use our GEN-232-9 cable (RJ45 to 9 pin serial D type connector) and a USB to serial adapter.

Products supplied by Digitus

### How to order

**Order Code for  
Digitus USB adapter:** ACC-GEN-337848

**Order code for  
RJ45 to 9 pin D type:** GEN-232-9

# Genesys™ 2U Parallel Kit – Master/Slave

Active current sharing allows up to four identical units to be connected in an auto-parallel configuration for four times the output power.

In Advanced Parallel Master/Slave Mode, total current is programmed and reported by the Master unit so that up to four Power Supplies can appear as just a single larger supply.

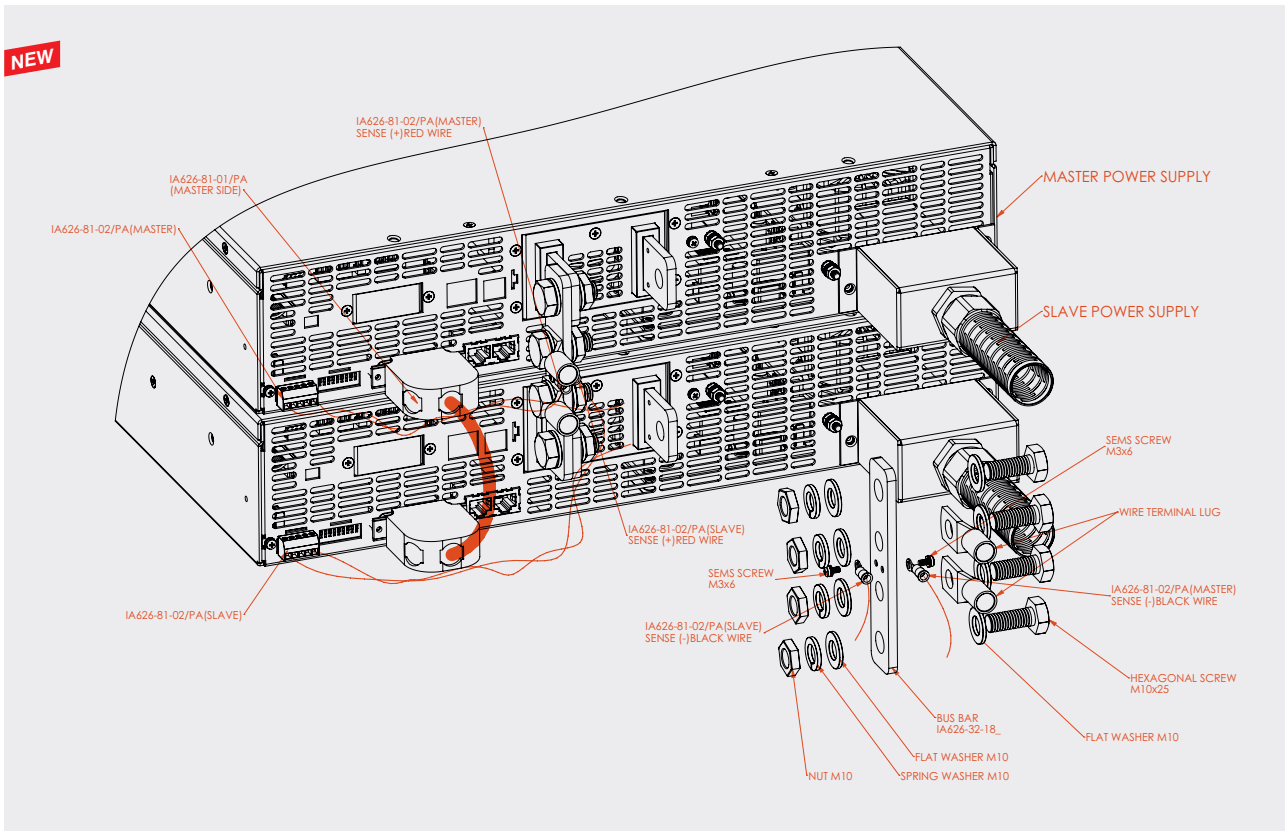

## How to order

### P/N of Genesys 2 U Parallel Kit

- GEN2U-LV – Parallel (8 V /10 V)
- GEN2U-MV – Parallel (16 V to 100 V)
- GEN2U-HV – Parallel (150 V to 600 V)

### KIT P/N for GEN30-165

- GEN2U-MV-PA

### Kit contains the following items:

- Bus bar for parallel operation - 2 sets
- M10 x 25 screw - 4 sets
- J1 DB25 Master/Slave harness
- +/- Sense harness - 2 sets

## ZUP 200/400/800 W



The Zero-up series extends our programmable product range below the Genesys series in terms of output power level from 200 W to 800 W with an output voltage range of up to 0-120 V.

Compact in size, ZUP can easily be integrated into test and measurement systems and are suitable for many applications such as automotive test and battery simulation, semiconductor manufacturing, medical and laboratory equipment, defence and aerospace ATE systems.

### Features

- Constant Voltage / Constant Current
- Built-in RS-232 & RS-485 Interface
- GPIB optional
- An embedded Microprocessor controller
- Voltage up to 120 V, Current up to 132 A
- Digital Encoder Knob
- Software Calibration
- Last Setting Memory
- Parallel Operation (Master/Slave) Active Current Sharing
- External Voltage or Resistance Programming
- Active Power Factor Correction: 99 %
- 85~265 V AC Universal Input Voltage
- 19" Rack Mounted ATE and OEM
- Worldwide Safety Agency Approvals
- CE Mark for LVD and EMC Regulation



# ZUP 200/400/800 W

Model	Output Voltage [V DC]	Output Current [A]	Output Power [W]
ZUP6-33 ZUP6-66 ZUP6-132	0~6	0~33 0~66 0~132	198 396 792
ZUP10-20 ZUP10-40 ZUP10-80	0~10	0~20 0~40 0~80	200 400 800
ZUP20-10 ZUP20-20 ZUP20-40	0~20	0~10 0~20 0~40	200 400 800
ZUP36-6 ZUP36-12 ZUP36-24	0~36	0~6 0~12 0~24	216 432 864
ZUP60-3.5 ZUP60-7 ZUP60-14	0~60	0~3.5 0~7 0~14	210 420 840
ZUP80-2.5 ZUP80-5	0~80	0~2.5 0~5	200 400
ZUP120-1.8 ZUP120-3.6	0~120	0~1.8 0~3.6	216 432

## How to order

### Power Supply Identification / Accessories

ZUP	36	-	12	/			
Series name	Output voltage (0~36 V)	Output current (0~12 A)	Front Panel L. Output Jack BLANK: Standard up to 60 V models	AC Cable E. Europe GB, UK J. Japan I. Middle East U. USA O. Unterminated BLANK: None	Serial Link Cable W. Cable included BLANK: None		

## Front panel description ZUP 200/400/800 W

- ① Digital Voltmeter
- ② Digital Amperemeter
- ③ Constant Voltage Mode Indicator
- ④ Constant Current Mode Indicator
- ⑤ Voltage/Current, OVP/UVP, Address Adjust
- ⑥ Alarm (OVP, OTP, FOLD)
- ⑦ Output ON/OFF Control
- ⑧ Local/Remote Select
- ⑨ Fold-back Protection Control
- ⑩ AC Power Switch
- ⑪ Voltage/Current Mode Control
- ⑫ Overvoltage/Undervoltage Setting
- ⑬ Address Setting

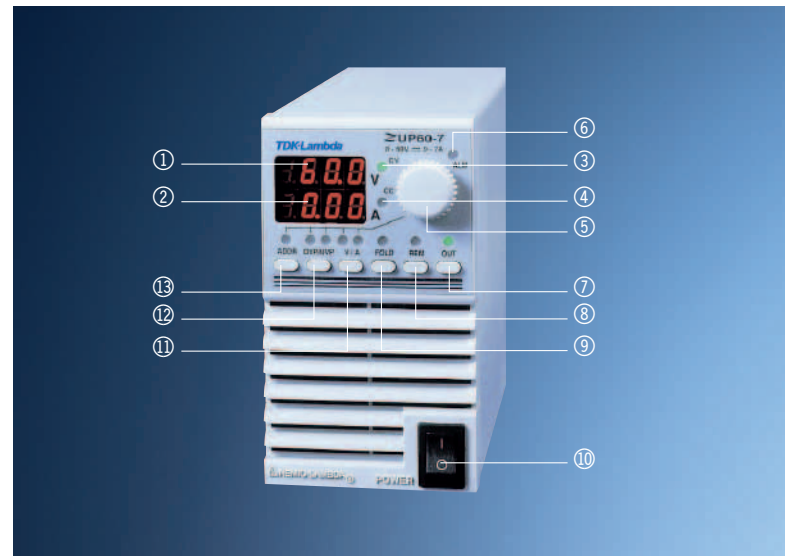

## Rear panel description ZUP 200/400/800 W

- ⑭ IEC320 AC Input Connectors
- ⑮ Remote IN Programming via RS-232/RS-485
- ⑯ Remote OUT via RS-485 Communications  
Chaining Power Supplies to Serial Communication Bus
- ⑰ External Analog Programming Control Connector
- ⑱ Output Bus Bars (6 V to 60 V) model shown.  
80 V to 120 V models PHOENIX: PSC Plug Connectors
- ⑲ Ground Thread

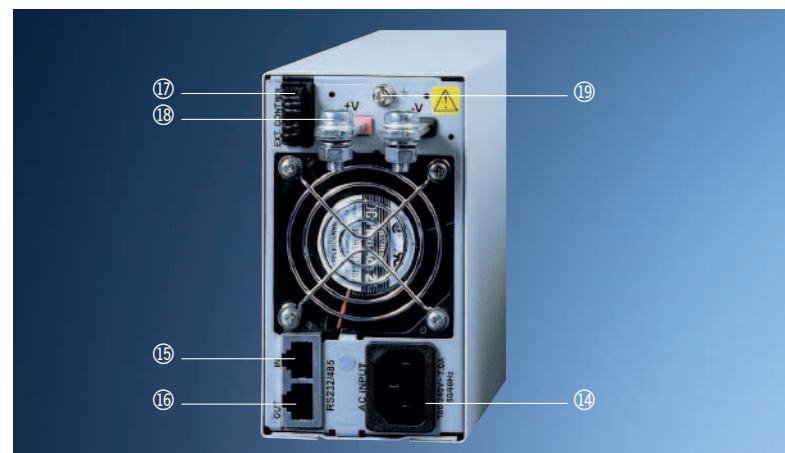

# Specifications ZUP Series

Model		ZUP	6-33	6-66	6-132	10-20	10-40	10-80	20-10	
Output voltage (*1)		[V]	0-6			0-10				
Output current (*2)		[A]	0-33	0-66	0-132	0-20	0-40	0-80	0-10	
Rated output power		[W]	198	396	792	200	400	800	200	
Constant voltage		ZUP	6-33	6-66	6-132	10-20	10-40	10-80	20-10	
Load regulation			0.005 % + 2 mV, From No load to Full load, constant input voltage							
Line regulation			0.005 % + 1 mV, From 85-132 V AC or 170-265 V AC, constant load							
RMS ripple (5 Hz–1 MHz Bandwidth)		[mV]	5		8	5		8		
Ripple (pk to pk) (20 MHz Bandwidth)		[mV]	50		100	50		90	50	
Recovery time (*3)		[ms]	1			0.5				
Temperature coefficient			30 ppm/°C from rated voltage following 30-minute warm-up							
Temperature drift (*8)		[mV]	0.01 % + 2							
UP Programming response time (*4)		[ms]	50							
Down programming		Full load	50							
Response time		No load	250			350				
Constant current		ZUP	6-33	6-66	6-132	10-20	10-40	10-80	20-10	
Load regulation (*5)		Full load	0.01 % + 5		0.07 % + 10	0.01 % + 5		0.07 % + 10	0.01 %	
Line regulation (*6)		[mA]	0.01 % + 2		0.01 % + 5	0.01 % + 2		0.01 % + 5	0.01 %	
RMS ripple (5 Hz–1 MHz Bandwidth)		[mA]	50	100	200	25	50	100	15	
Temperature coefficient			100 ppm/°C from rated current following 30-minute warm-up							
Temperature drift (*8)		[mA]	0.02 % + 5		0.05 % + 10	0.02 % + 5		0.05 % + 10	0.02	
Programming (*9)		ZUP	6-33	6-66	6-132	10-20	10-40	10-80	20-10	
Voltage		Resolution	Better than 0.028 % of rated output voltage							
		Accuracy	0.02 % + 5			0.02 % + 8				
Current		Resolution	Better than 0.03 % of rated output voltage							
		Accuracy	0.4 % + 40							
Model		ZUP	6-33	6-66	6-132	10-20	10-40	10-80	20-10	
Overvoltage Protection (*10)		[V]	0-7.5			0-13				
Hold-up time			20 ms @ 100 V/200 V AC, rated output voltage and output current							
Display		Voltage	3 digits (6 V; 20 V; 36 V; 60 V; 80 V); 3.5 digits (10 V; 120 V) accuracy: 0.2 % ± 2 digits							
		Current	3.5 digits (132 A); All others 3 digits, accuracy: 0.5 % ± 3 digits							
		Status	CV/CC, Alarm, Fold, Local/Remote, On/Off							
Output Protections			Over Voltage, Over Temperature, Fold-back							
Input		Input voltage (*11)	85–265 V AC Continuous, 47–63 Hz							
		Input current (*12)	[A]	3.0/1.5	5.6/2.7	11.2/5.4	2.9/1.4	5.6/2.7	11.2/5.4	2.9/1.4
		Inrush current (100/200 V AC)	[A]	15/30 (*7)	15	30	15/30 (*7)	15	30	15/30 (*7)
		Efficiency (*12)	[%]	69/72	74/77		73/77	79/82	77/81	74/78
		Input current harmonics		Complies with EN61000-3-2, Class A						
		Power factor (TYP)		0.99 at 100/200 V AC, 100 % load						
Environment		Operating temperature	0 ~ 50 °C, 100 % load							
		Operating humidity	30 – 90 % RH (No dewdrop)							
		Storage temperature	–20 ~ 70 °C							
		Operating humidity	10 – 95 % RH (No dewdrop)							
Mechanical		Vibration	10 – 55 Hz, Amplitude (sweep 1 min) 2 G, X, Y, Z (When mounted with mounting screws)							
		Shock	Less than 20 G							
		Weight	[kg]	2.9	3.2	5.8	2.9	3.2	5.8	2.9
		Size (WxHxD)	[mm]	200 W and 400 W units: 70 x 124 x 350 800 W units: 140 x 124 x 350 (Refer to outline drawing)						

\*1, \*2, \*3, \*4, \*5, \*6, \*8, \*11, \*12: annotation on page 100.

20-20	20-40	36-6	36-12	36-24	60-3.5	60-7	60-14	80-2.5	80-5	120-1.8	120-3.6
0-20		0-36			0-60			0-80		0-120	
0-20	0-40	0-6	0-12	0-24	0-3.5	0-7	0-14	0-2.5	0-5	0-1.8	0-3.6
400	800	216	432	864	210	420	840	200	400	216	432
20-20	20-40	36-6	36-12	36-24	60-3.5	60-7	60-14	80-2.5	80-5	120-1.8	120-3.6
								0.005 %+4 mV			
								0.005 %+2 mV			
5								20			
80	50		70	50		60	70		80		
0.2											
								100			
50						70	60		80		
400	500			750			800		1000		
20-20	20-40	36-6	36-12	36-24	60-3.5	60-7	60-14	80-2.5	80-5	120-1.8	120-3.6
+5	0.07 %+10	0.01 %+5		0.07 %+10	0.01 %+5		0.07 %+10	0.01 %+5			
+2	0.01 %+5	0.01 %+2		0.01 %+5	0.01 %+2		0.01 %+5	0.01 %+2			
30	60	7.5	15	30	5	10	20	5			
%+5	0.05 %+10	0.02 %+5		0.05 %+10	0.02 %+5		0.05 %+10	0.02 %+5			
20-20	20-40	36-6	36-12	36-24	60-3.5	60-7	60-14	80-2.5	80-5	120-1.8	120-3.6
0.02 %+12		0.02 %+20			0.02 %+35			0.02 %+50		0.02 %+80	
								0.4 %+15	0.4 %+30	0.4 %+10	0.4 %+20
20-20	20-40	36-6	36-12	36-24	60-3.5	60-7	60-14	80-2.5	80-5	120-1.8	120-3.6
0-24		0-40			0-66			0-88		0-132	
5.6/2.7	11.2/5.4	2.9/1.4	5.6/2.7	11.2/5.4	2.9/1.4	5.6/2.7	11.2/5.4	2.6/1.3	4.9/2.4	2.9/1.4	5.3/2.6
15	30	15/30 (*7)	15	30	15/30 (*7)	15	30	15/30 (*7)	15	15/30 (*7)	15
79/83	79/82	76/80	80/84		75/79	80/84		78/82	83/87	78/82	82/86
3.2	5.8	2.9	3.2	5.8	2.9	3.2	5.8	2.9	3.2	2.9	3.2

Model		ZUP	6-33	6-66	6-132	10-20	10-40	10-80	20-10
External control Functions	Output on/off		By TTL Signal or Dry Contact (Refer to instruction manual)						
	Output good		Open collector (Refer to instruction manual).						
	Output voltage programming		By Voltage (0–4 V) or by Resistance (0–4 K) (Refer to instruction manual)						
	Output current Programming		By Voltage (0–4 V) or by Resistance (0–4 K) (Refer to instruction manual)						
	Remote sensing		Maximum 0.5 V drop on each load wire for model up to 60 V and 2 V for the 80 V,						
	Communication interface		RS232 and RS485 Built-in, IEEE488 Optional						
Approvals	Safety standards		UL3111-1, EN61010-1						
	EMC standards		EN61326-1, IEC 61326-1, FCC part 15 (class A)						
Conducted EMI			EN55022-B, FCC-B, VCCI-2						
Radiated EMI			EN55022-A, FCC-A, VCCI-1						
Series operation			Up to 2 units (Refer to instruction manual)						
Parallel operation			Master/Slave method; up to 5 units (Refer to instruction manual)						
Cooling			Forced air by blower fan (Blower fan is mounted within unit)						
Withstand voltage			Input – Chassis...2.0 kV AC 1 min, Input – Output...3.0 kV AC 1 min,						
Isolation resistance			More than 100 MΩ at 25 °C and 70 % R.H.						

\*1: Minimum voltage is guaranteed to maximum 0.2% of the rated output voltage.

\*2: Minimum current is guaranteed to maximum 0.4% of the rated output current.

\*3: Time for recovery to within  $\pm 50$  mV against current change of 50% to 100%.

\*4: From zero volts to full scale, resistive load and current setting at maximum.

\*5: From no load to full load, constant input voltage.

\*6: From 85~132 V AC or 170~265 V AC constant load.

\*7: At cold start  $T_a=25$  °C.

\*8: Change in output over 8 hour interval constant line, load and ambient temperature following 30-minutes warm-up.

\*9: Given for control of the output via the serial communication or via front panel controls.

\*10: Inverter shut-down method, manual reset by AC Input recycling (OVP will shut-down output).

\*11: For cases where conformance to various safety specs. (UL, IEC, etc.) are required, to be described as 100–240 V AC (50/60 Hz) on name plate.

\*12: At 100 V/200 V AC and Maximum Output Power.



# GP485A

The GP485A GPIB ↔ RS485 Controller has all the software and logic required to implement the physical and electrical specifications of the IEEE488 and RS-485 standards.



## Front panel description GP485A

- ① Power/Ready: Indicates that the power is ON and the self-test has passed successfully. The unit is ready to operate once the LED illuminates.
- ② Talk: Indicates that the GP485A is addressed as a GPIB Talker.
- ③ Listen: Indicates that the GP485A is addressed as a GPIB Listener.
- ④ SRQ: Indicates that the GP485A signal line SRQ is asserted.
- ⑤ AC ON/OFF: Turns AC power On and Off.

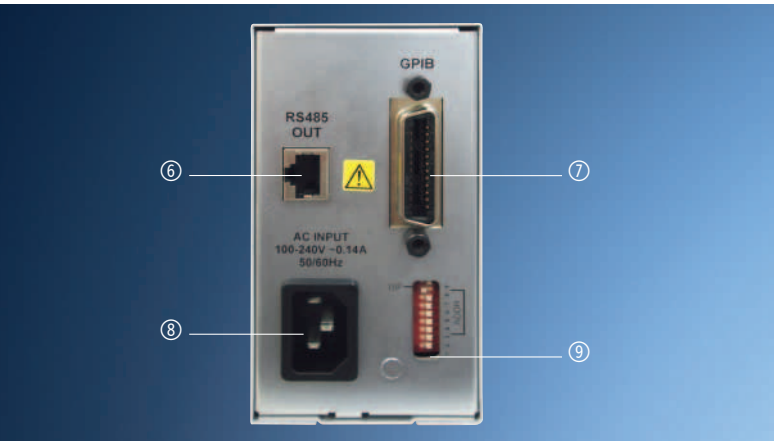

## Rear panel description GP485A

- ⑥ RS-485 OUT: EIA-568A /R2-45 shielded type connector, used for RS-485 communication with ZUP power supplies.
- ⑦ GPIB: Shielded 24-pin Champ female connector, with metric screwlock. Used for GPIB communication with the GPIB controller.
- ⑧ AC Input: IEC type appliance inlet.
- ⑨ Address Select: 9 Position DIP switch. Position 4 to 8 used for address selection.

# Specifications GP485A

Model	GP485A
Input Voltage/freq.	85 ~ 265 V AC continuous 47 ~ 63 Hz
Input consumption	5 W
IEEE 488 Capability	SH1, AH1, T6, TE0, L4, LE0, SR1, RL0, PP1, DC1, DT0, C0, E1, E2
Indication LED's	Power/Ready, Talk, Listen, SRQ
Baud rate	Optional 300, 600, 1200, 2400, 4800, 9600 bps    Default:9600 bps
Address	1 up to 30 can be set using an address switch
Operating temperature	0 ~ 50 °C
Storage temperature	-20 ~ 70 °C
Conducted emission	EN5022B, FCC-B
Radiated emission	EN5022A, FCC-A
Safety standards	UL3111-1, EN61010-1
EMC standards	EN61326-1, IEC 61326-1, FCC part 15 (class A)
Withstand voltage	Input – Chassis 2.0 kV AC 1 min, Input – Output 3.0 kV AC 1 min, Output – Chassis 500 V AC 1 min.
Vibration	10 – 55 Hz, Amplitude (sweep 1 min) 2 g, X, Y, Z, when mounted with mounting screws
Size (WxHxD)	70 x 124 x 350 mm (GP 485 A has all the mechanical specifications & mounting hole as ZUP 200 W/400 W units)
Weight	1.95 kg

# Outline drawings ZUP 200/400 W Units

## Dimensions:

200 W / 400 W units:  
70 x 124 x 350 mm

## Weight:

200 W units: 2.9 kg  
400 W units: 3.2 kg

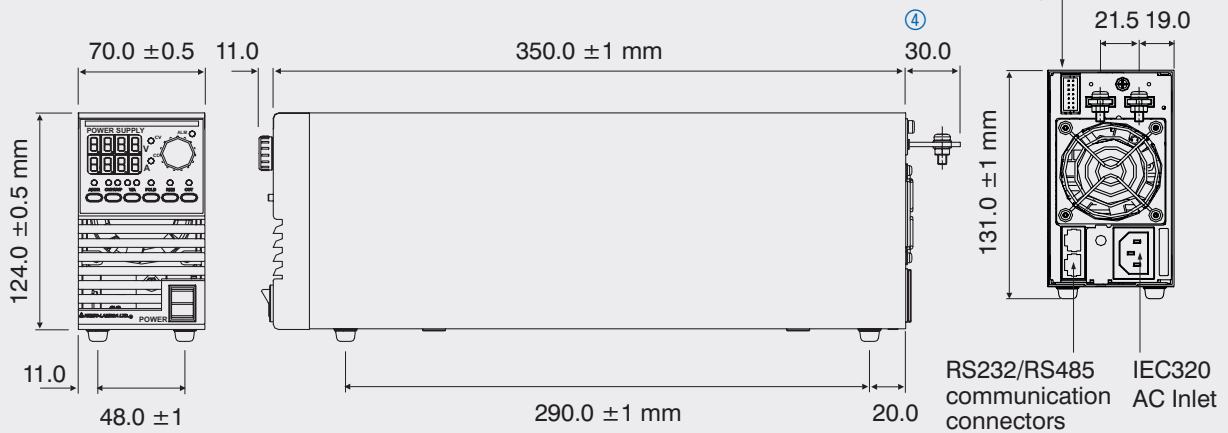

## 6 V to 60 V Models

External  
Control  
Connector

21.5 19.0

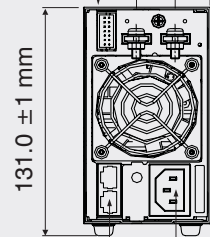

RS232/RS485  
communication  
connectors

IEC320  
AC Inlet  
connectors

## 80 V and 120 V Models

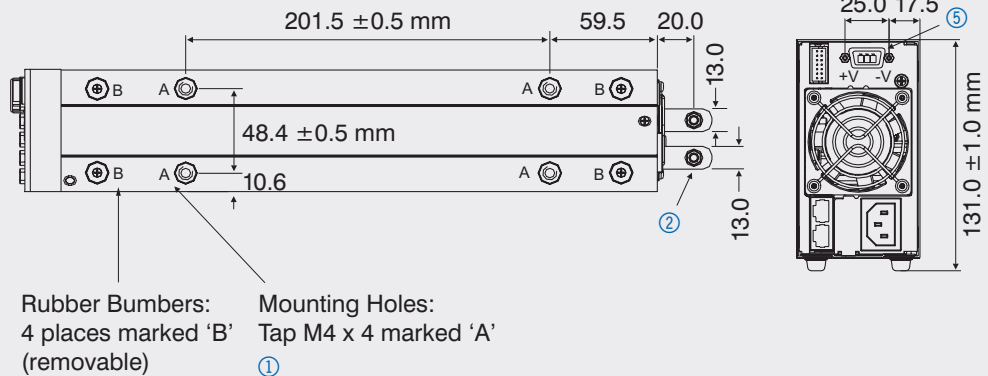

Rubber Bumpers:  
4 places marked 'B'  
(removable)

Mounting Holes:  
Tap M4 x 4 marked 'A'  
①

- ① Mounting screws must not protrude more than 6 mm into the power supply.
- ② Use M6 or 1/4" screw for load wires connection, enclosed in the package at time of shipment.
- ③ Receptacle: AMP, 87631-9, 14 contacts, double row. PIN: 87523-5 or 87523-6
- ④ For 6V to 60V models.
- ⑤ Male connector (P.S. side): PSC 1.5/3-M-PE, Phoenix  
Accessories: Female connector (user side): PSC 1.5/3-F, Phoenix Strain relief plastic housing.

## Outline drawings ZUP 800 W Units

**Dimensions:** 140 x 124 x 350 mm

**Weight:** 5.8 kg

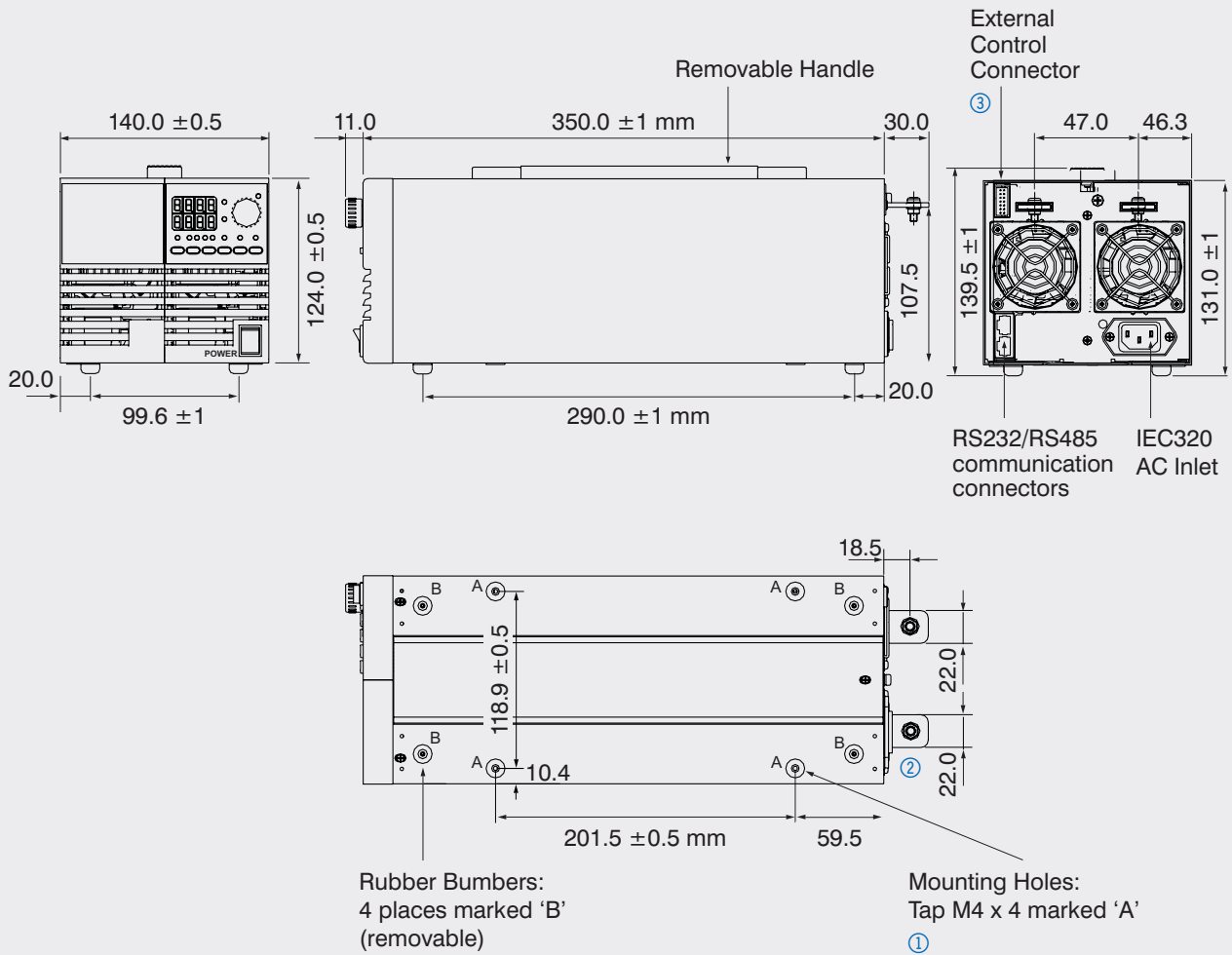

- ① Mounting screws must not protrude more than 6 mm into the power supply.
- ② Use M8 or 5/16" screw for load wires connection, enclosed in the package at time of shipment.
- ③ Receptacle: AMP, 87631-9, 14 contacts, double row. PIN: 87523-5 or 87523-6



# ZUP Standard Configurations

## Benchtop Power Supply



Single



Parallel (Master/Slave)

### Parallel Operation

Master – Slave method: Active current sharing up to 5 units.

## Remote Programming via RS-232 and RS-485 Interface

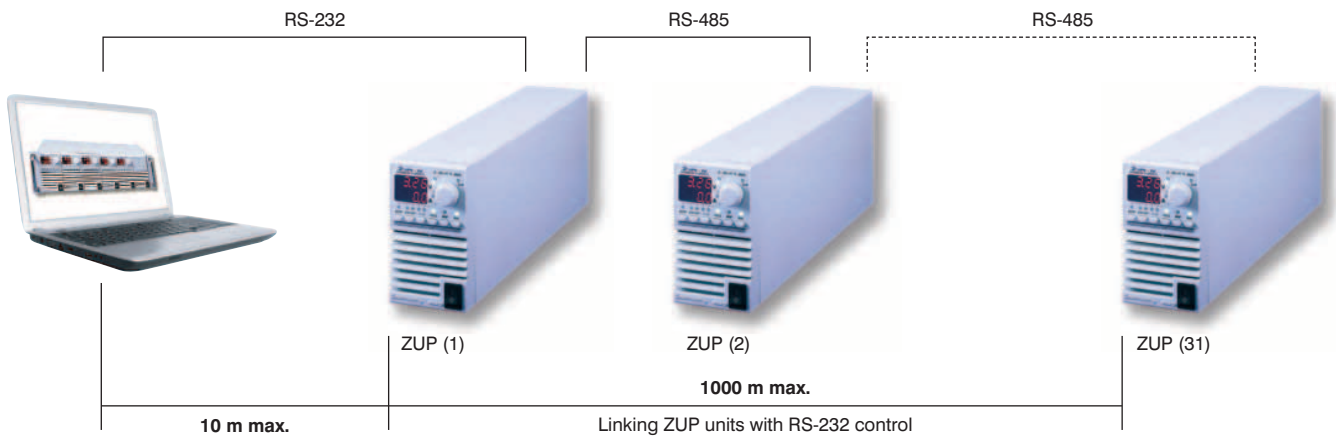

Up to 31 ZUP units can be connected to the RS-232 control.

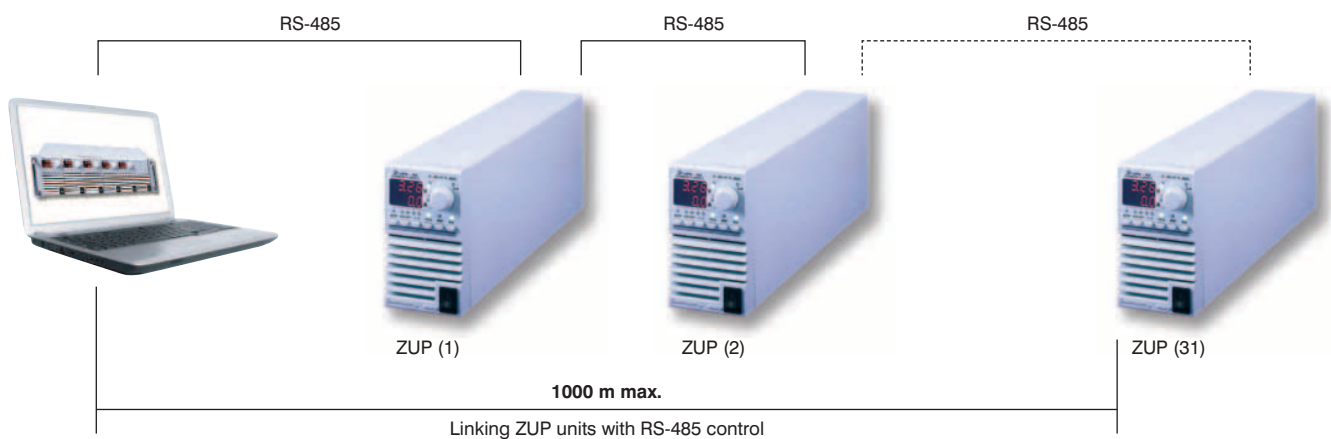

Up to 31 ZUP units can be connected to the RS-232 control.

For operation environments that require high noise immunity or long distance communication, it is recommended to use the built-in RS-485 interface.

# ZUP Interface Option

## GPIB – RS-485 Controller

The GP485A is a high performance serial to GPIB Interface. It enables a ZUP series with RS-485 port to be a Talker, Listener, or Controller on the GPIB.



- Controls up to 31 ZUP units through a single GPIB address
- Conforms to all versions of the IEEE488 standard, including IEEE488.2
- 19" racking possibility
- Application software LabView, LabWindows

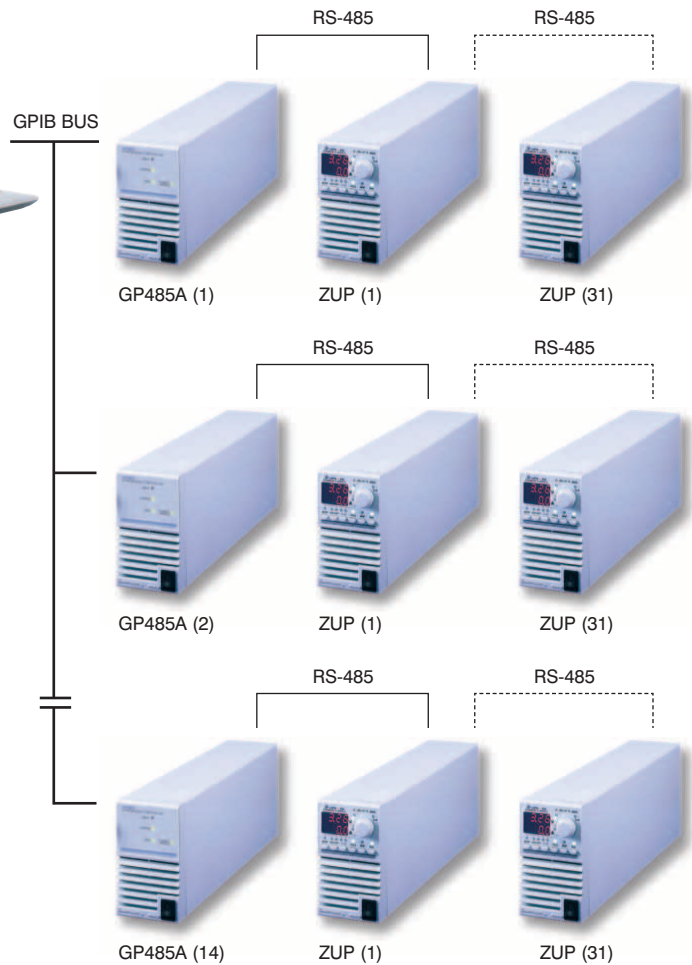

# Rack Mounted ATE and OEM

## up to 2.4 kW

Six units can be assembled into 19-inch rack / 3U high to meet your configuration requirements.

### Power Modules Table

Model Type	200 W	400 W	800 W
0 ~ 6 V	33 A	66 A	132 A
0 ~ 10 V	20 A	40 A	80 A
0 ~ 20 V	10 A	20 A	40 A
0 ~ 36 V	6 A	12 A	24 A
0 ~ 60 V	3.5 A	7 A	14 A
0 ~ 80 V	2.5 A	5 A	
0 ~ 120 V	1.8 A	3.6 A	
19" rack width	1/6 width	1/6 width	2/6 width



## ZUP Options 200 / 400 / 800 W Models



### Front Panel Output Jacks

Up to 20 A output current via front panel jacks, only for models up to 60 V output voltage.

Outline Drawing: Physical Dimensions in mm.

ZUP 200/400 W Units: 70 x 153 x 405.9

ZUP 800 W Units: 140 x 153 x 405.9

P/N: ZUP / L

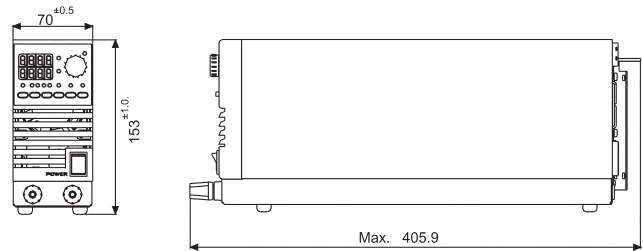

### ZUP Assemblies

Dual Output Packing 200/400 W models

P/N: NL200

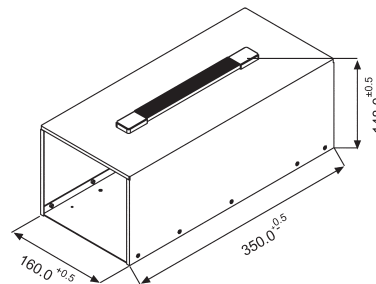

### 19" Rack mounted and OEM up to 2.4 kW

Up to six power units can be assembled into a 19, 3 U rack, kit.

P/N: NL100



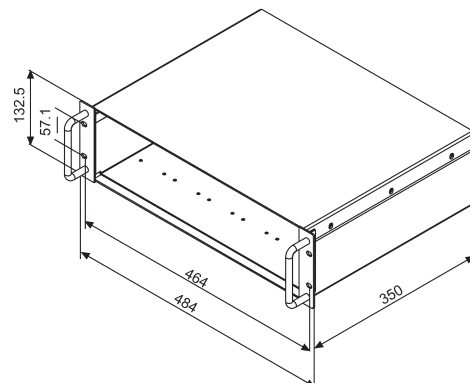

In cases where the entire rack is not occupied with power units, NL101 blank panels can be installed. P/N: NL100



# ZUP Accessories

## AC Cords sets

Five optional cords are possible according to order:

Region	Europe	United Kingdom	Japan	Middle East	North America
Output Power AC Cords	750 W 10 A/250 V AC L=2 m	750 W 10 A/250 V AC L=2 m	750 W 13 A/125 V AC L=2 m	750 W 10 A/250 V AC L=2 m	750 W 13 A/125 V AC L=2 m
Wall Plug Power Supply Connector	INT'L 7/VII IEC320-C13	BS1363 IEC320-C13	IEC320-C13	SI-32 IEC320-C13	NEMA 5-15P IEC320-C13
					
Part Number	P/N: ZUP/E	P/N: ZUP/GB	P/N: ZUP/J	P/N: ZUP/I	P/N: ZUP/U

## Communication cable

RS-232/RS-485 cable is used to connect the power supply to the PC controller.

Mode	PC connector	Communication cable	Power Supply Connector	P/N
RS232	DB-9	Shield Ground L=1 m	EIA / TIA-568A (RJ-45)	ZUP/NC401
RS232	DB-25	Shield Ground L=1 m	EIA / TIA-568A (RJ-45)	ZUP/NC403
RS485	DB-9	Shield Ground L=1 m	EIA / TIA-568A (RJ-45)	ZUP/NC402
RS485	DB-25	Shield Ground L=1 m	EIA / TIA-568A (RJ-45)	ZUP/NC404

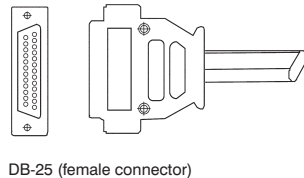

DB-25 (female connector)

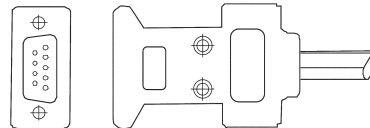

DB-9 (female connector)

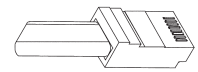

EIA/TIA (RJ-45)

## Serial link cable

Used to chain Power Supply to Power Supply from a serial communication bus

Mode	Communication cable	Power Supply Connector Remote IN/OUT	P/N
RS485	Shield Ground L=50 cm	EIA / TIA-568A (RJ-45)	ZUP/W



